



INVERTER

7200GS

(SENSORLESS VECTOR)

INSTRUCTION MANUAL

220V Class	3Φ	25~100HP
440V Class	3Φ	25~400HP

Please hand this manual to the end-users. It will be of great help for their daily operation, maintenance, inspection and troubleshooting.

BEFORE INSTALLATION & USE

1. Ensure nameplate data corresponds with your requirements.
2. Ensure the apparatus is undamaged.

WARNING

The following safety precautions must be observed:

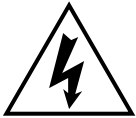

1. Electric apparatus and electricity can cause serious or fatal injury if the apparatus is improperly installed, operated or maintained. Responsible personnel must be fully trained to understand the hazards to themselves and others before being involved in installing, operating, maintaining and decommissioning electrical apparatus. European Union Safety information can be obtained from such as:

BS4999; EN60204-11 EN292-1 EN294
IEE Wiring Regulations

Particular industries and countries have further safety requirements. Refer to their trade safety bodies, British Standards Institution, Dept. of Trade & Industry, etc., for further information. For instance, in the USA, refer to NEMA MG2, the National Electrical Code, local safety requirements, etc.

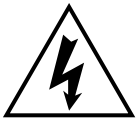

2. When servicing, all power sources to the apparatus and to the accessory devices should be de-energized and disconnected and all moving parts at standstill.
3. Safety guards and other protective, devices must neither be bypassed nor rendered inoperative.



4. The apparatus must be earthed. Refer to relevant standards such as EN60204-1, IEE Wiring Regulation etc.
5. A suitable enclosure must be provided to prevent access to live parts. Extra caution should be observed around apparatus that is automatically started or has automatic resetting relays or is remotely started in case such starting means has not been properly disabled and the apparatus starts unexpectedly.

CAUTION AND WARNING:

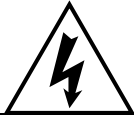

WARNING

- Do not change the wiring while power is applied to the circuit.
- After turning OFF the main circuit supply, do not touch circuit components until CHARGE LED is extinguished.
- Never connect power circuit output U (T1), V (T2), W (T3) to AC power supply.
- When the retry function (Cn-36) is selected, motor may restart suddenly after being stopped by momentary power loss.



CAUTION

- When mounting units in a separate enclosure, install a fan or other cooling device to keep the intake air temperature below 45 °C.
- Do not perform a withstand voltage test to the inverter.
- All the constants of the inverter have been factory preset. Do not change the settings unnecessarily.

CONTENTS

PART I INSTALLATION MANUAL	Pages
1. GENERAL	1-1
1.1 SAFE OPERATION NOTES	1-1
1.2 PRODUCT CHANGES.....	1-1
2. RECEIVING	2-1
3. INSTALLATION	3-1
3.1 MOUNTING SPACE.....	3-1
3.2 LOCATION	3-2
4. WIRING	4-1
4.1 NOTES ON WIRING TO PERIPHERAL UNITS	4-1
4.2 CONNECTION DIAGRAM	4-2
4.3 TERMINAL FUNCTION.....	4-3
4.3.1 MAIN CIRCUIT TERMINALS	4-3
4.3.2 CONTROL CIRCUIT TERMINALS.....	4-3
4.3.3 MAIN CIRCUIT SCHEMATIC.....	4-4
4.4 WIRING PARTS	4-5
4.4.1 RECOMMENDED WIRING PARTS	4-5
4.4.2 CAUTIONS FOR WIRING	4-7
5. TEST OPERATION	5-1
5.1 CHECK BEFORE TEST OPERATION	5-1
5.2 SETTING THE LINE VOLTAGE SELECTING CONNECTOR.....	5-1
6. MAINTENANCE	6-1
6.1 PERIODIC INSPECTION.....	6-1
6.2 SPARE PARTS	6-2
7. SPECIFICATIONS	7-1
8. DIMENSIONS	8-1
9. PERIPHERAL AND OPTIONS	9-1
9.1 AC REACTOR.....	9-1
9.2 NOISE FILTER.....	9-2
9.2.1 INPUT NOISE FILTER	9-2
9.2.2 EMI SUPPRESSION ZERO CORE	9-3
9.3 BRAKING RESISTOR AND BRAKING UNIT	9-4
9.4 OTHERS	9-5
9.4.1 DIGITAL OPERATOR WITH EXTENSION WIRE	9-5
9.4.2 ANALOG OPERATOR	9-6
9.4.3 LED DIGITAL OPERATOR.....	9-6
9.4.4 OPTION CARDS.....	9-7

PART II OPERATION MANUAL

Pages

1. DESCRIPTION OF USING 7200GS	1-1
1.1 Using LCD (OR LED) digital operator	1-1
1.2 DRIVE mode and PRGM mode displayed contents	1-3
1.3 Parameter description	1-4
1.4 Sample example of using LCD digital operator	1-5
1.5 Control mode selection	1-7
2. SETTING USER CONSTANT	2-1
2.1 Descriptions of Constant / function list	2-1
2.2 Frequency Command An-	2-2
2.3 Parameters Can Be Changed during Running Bn-	2-3
2.4 System Parameters Sn-	2-10
2.5 Control Parameters Cn-	2-68
2.6 Monitoring Parameters Un-	2-88
3. FAULT DISPLAY AND TROUBLE SHOOTING	3-1
4. APPENDIX:	
A. SENSORLESS VECTOR CONTROL	4-1
B. AUTO ENERGY-SAVING CONTROL IN PID CONTROL MODE	4-4
C. PID CONTROL IN PID CONTROL MODE	4-9
D. PG FEEDBACK CONTROL	4-15
E. NOTES ON APPLICATION OF MOTORS	4-19
F. PERIPHERAL UNIT NOTES	4-20
G. CIRCUIT PROTECTION AND ENVIRONMENTAL RATING NOTES	4-21
H. DRIVE INPUT FUSES	4-23
I. CERTIFICATION FOR THE INVERTER	4-24

PART I

INSTALLATION MANUAL

1. GENERAL

1.1 SAFE OPERATION NOTES

Read this installation manual thoroughly before installation, operation, maintenance or inspection of the inverter. Only authorized personnel should be permitted to perform maintenance, inspections or parts replacement.

In this manual, notes for safe operation are classified as:

"WARNING" or "CAUTION".



: Indicates a potentially hazardous situation which, if not avoided, could result in death or serious injury to personnel.



: Indicates a potentially hazardous situation which, if not avoided, may result in minor or moderate injury to personnel and damage to equipment. It may also be used to alert against unsafe practices.

This inverter has been placed through demanding tests at the factory before shipment. After unpacking, check for the following:

1. Verify that part numbers on shipping carton and unit match the purchase order sheet and/or packing list.
2. Do not install or operate any inverter which is damaged or missing parts.
3. Do not install or operate any inverter which has no QC marking.

Contact your local distributor or TECO representative if any of the above have been found.

1.2 PRODUCT CHANGES

TECO reserves the right to discontinue or make modifications to the design of its products without prior notice, and holds no obligation to make modifications to products sold previously. TECO also holds no liability for losses of any kind which may result from this action.

2. RECEIVING



CAUTION

This 7200GS has been put through demanding tests at the factory before shipment. After unpacking, check the followings.

- Verify the received product with the purchase order sheet (invoice) and/or packing list.
- Transit damage.

If any part of 7200GS is damaged or lost, immediately notify the shipper.

NAMEPLATE DATA (220V CLASS 75HP example)

MODEL	JNTEBGBA0075JK- - -
	220V CLASS INVERTER
INPUT	AC 3PH 200-240V 50/60Hz
OUTPUT	AC 3PH 0-240V 81KVA 212A
SER. NO.	
東元電機股份有限公司 TECO Electric & Machinery Co., Ltd.	
	

← Inverter Model

← Input Spec.

← Output Spec.

← Series No.

← CE Mark

MODEL DESIGNATION

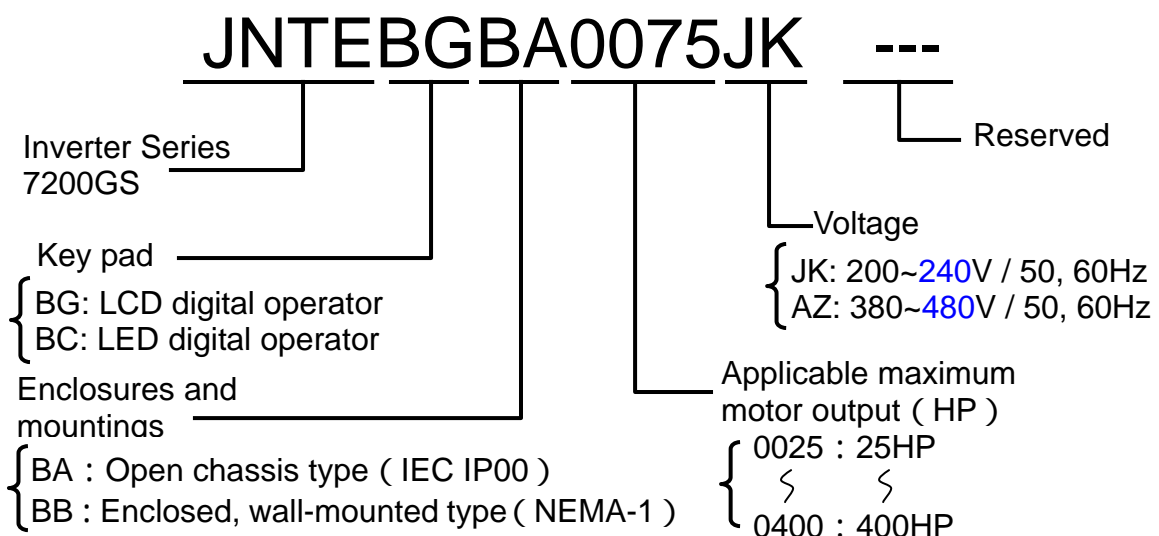

3. INSTALLATION



CAUTION

- Never move, lift or handle the 7200GS cabinet by the front cover.
- Lift the cabinet from the bottom.
- Do not drop the inverter.

3.1 MOUNTING SPACE

Install 7200GS vertically and allow sufficient space for effective cooling as shown in Fig. 1.

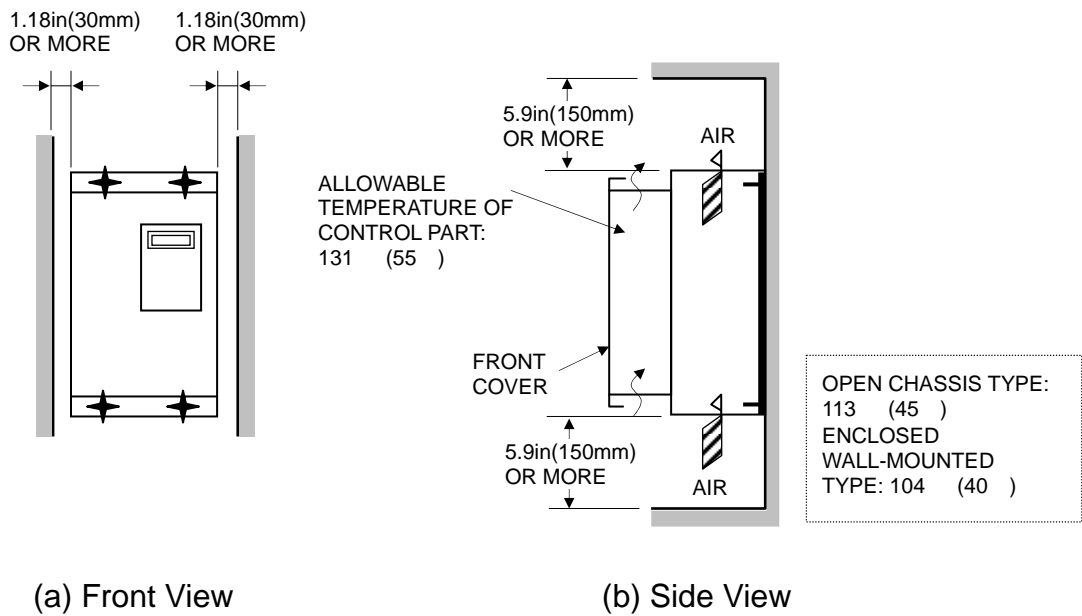

Note: For product external dimensions and mounting dimensions, refer to "DIMENSIONS" on page 23.

Fig. 1 Mounting Spaces

3.2 LOCATION

Location of the equipment is important to achieve proper performance and normal operating life. The 7200GS should be installed in areas where the following conditions exist:

- Protected from rain or moisture.
- Protected from direct sunlight.
- Protected from corrosive gases or liquids.
- Free from airborne dust or metallic particles.
- Free from vibration.
- Free from magnetic noise (e.g. welding machines, power units)
- Ambient temperature:
 - +14 to 104 °F, -10 to +40 °C (For enclosed type),
 - +14 to 113 °F, -10 to +45 °C (For open chassis type)
- Free from combustible materials, gases, etc.



CAUTION



When mounting multiple units in a common enclosure, install a cooling fan or some other means to cool the air entering the inverter to at least 113 °F (45 °C) or below.

4. WIRING

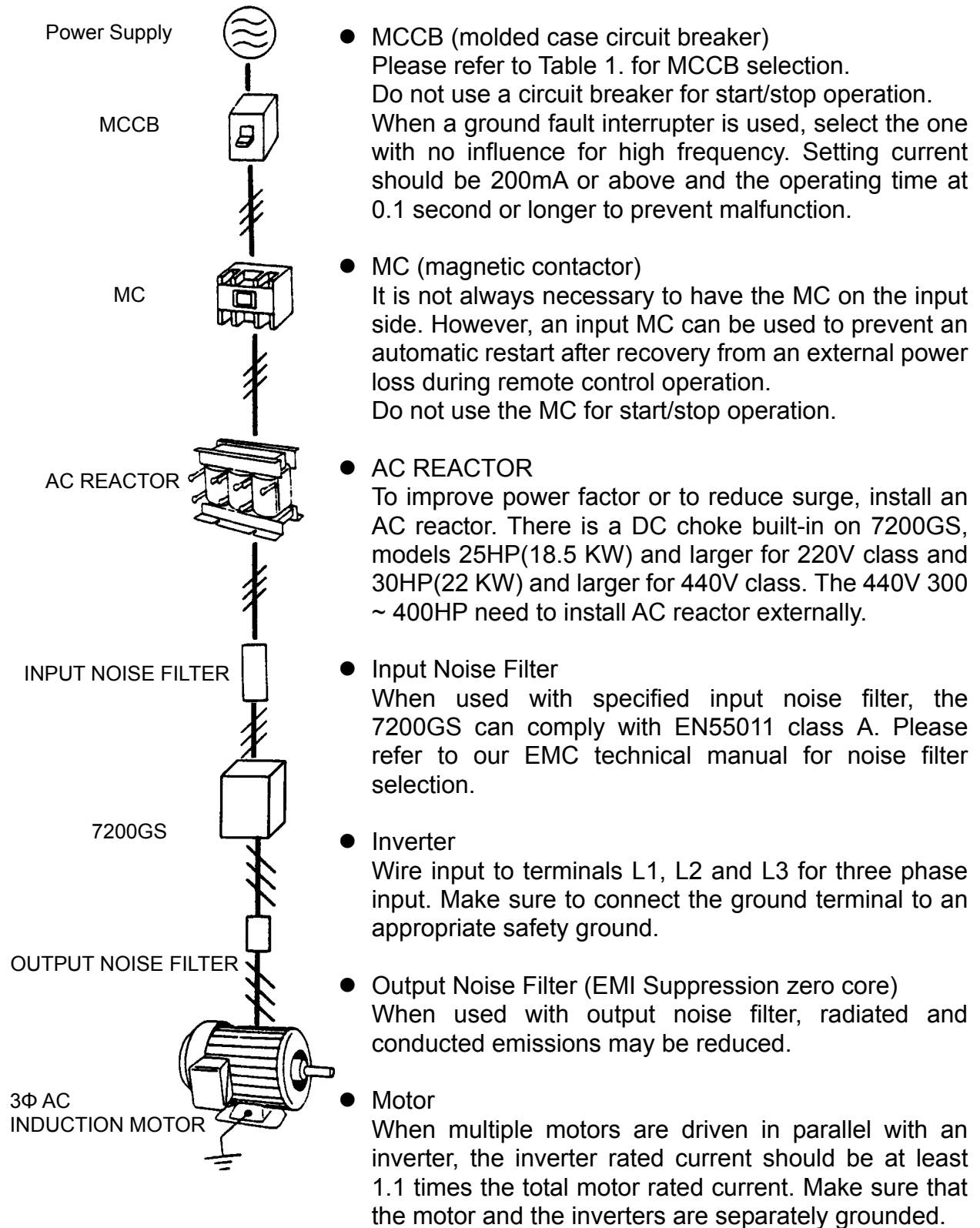
4.1 NOTES ON WIRING TO PERIPHERAL UNITS



4.2 CONNECTION DIAGRAM

The following diagram shows interconnection of the main circuit and control circuit. With the digital operator, the motor can be operated by wiring the main circuit only. (Terminal Symbols:  indicates main circuit;  indicates control circuit).

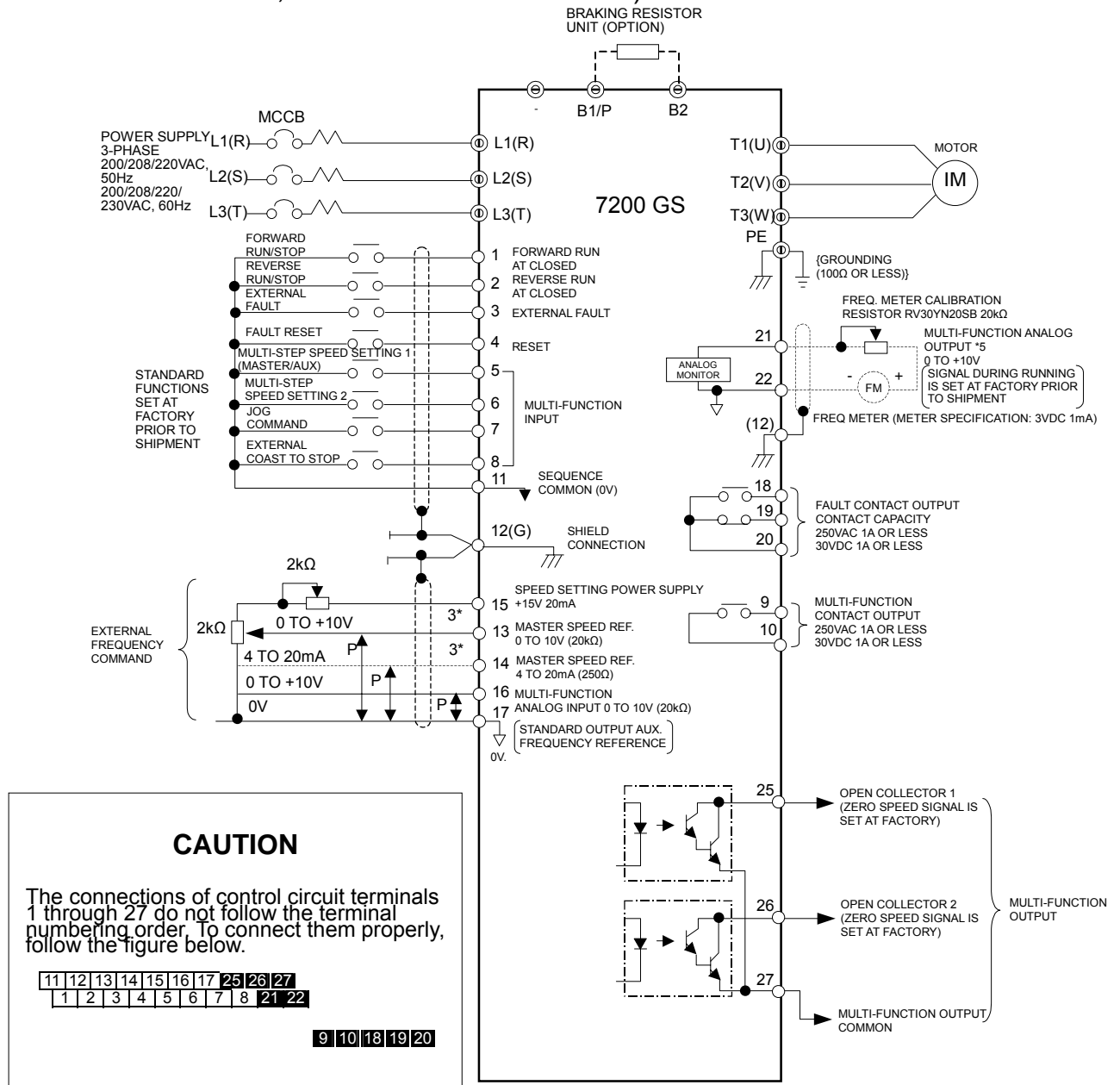

Notes:



-  indicates shielded wire and  twisted pair shielded wire.
- Control circuit terminal 15 of +15V has maximum output current capacity of 20mA.
- Either external terminal 13 or 14 can be used.
(For simultaneous input, two signals are internally added in the unit).
- Multi-function analog output is an exclusive meter output such as frequency meter etc. and not available for the feedback control system.
- Control circuit terminal 12 is frame ground of the unit.

Fig. 2 Standard connection diagram.

4.3 TERMINAL FUNCTION

4.3.1 MAIN CIRCUIT TERMINALS

Table 1. Main Circuit Terminals

HP Range Terminals	440V: 25HP	220V: 25~100HP 440V: 30~400HP
R / L1	Main Circuit Input Power Supply	
S / L2		
T / L3		
U / T1	Inverter Output	
V / T2		
W / T3		
B1/P	<ul style="list-style-type: none"> ● B1/P - B2: Braking Resistor ● B1/P - - : DC power supply 	-
B2		
-		● + ~ - : DC Power Supply or Braking Unit
+	-	
E (PE, \perp)	Grounding (3rd Type Grounding)	

4.3.2 CONTROL CIRCUIT TERMINALS

Table 2. Control Circuit Terminals

Terminal	Functions	
1	Forward operation-stop signal	
2	Reverse operation-stop signal	
3	External fault input	
4	Fault reset	
5	Multi-function contact input: the following signals available to select. Forward/reverse select, run mode select, multi-speed select, jog frequency select, accel/decel time select, external fault, external coast to stop, hold command, inverter overheat prediction, DB command, aux. input effective, speed search, energy-saving operation.	
6		
7		
8		
9	Multi-function contact output: one of the following signals available to output. Output during running, zero speed, synchronized speed, arbitrary speed agreed, frequency detection, overtorque, undervoltage, run mode, coast to stop, braking resistor overheat, alarm, fault.	
10		
11	Sequence control input common terminal.	
12	Connection to shield sheath of signal lead.	
13	Master speed voltage reference (0 to 10V).	
14	Master speed current reference (4 to 20mA).	
15	+15V	
16	Aux. analog command: one of the following signals available to select. Frequency command, frequency gain, frequency bias, overtorque detection level, voltage bias, accel/decel rate, DB current.	
17	Common terminal for control circuit (0V).	
18	Fault contact output a (Closed at fault).	
19	Fault contact output b (Open at fault).	
20	Fault contact output common.	
21	Multi-function analog monitor (+).	Output current or output frequency is selectable.
22	Multi-function analog monitor (-).	
25	Multi-function PHC output 1.	The same as terminals 9 and 10
26	Multi-function PHC output 2.	
27	Multi-function PHC output common.	

4.3.3 MAIN CIRCUIT SCHEMATIC

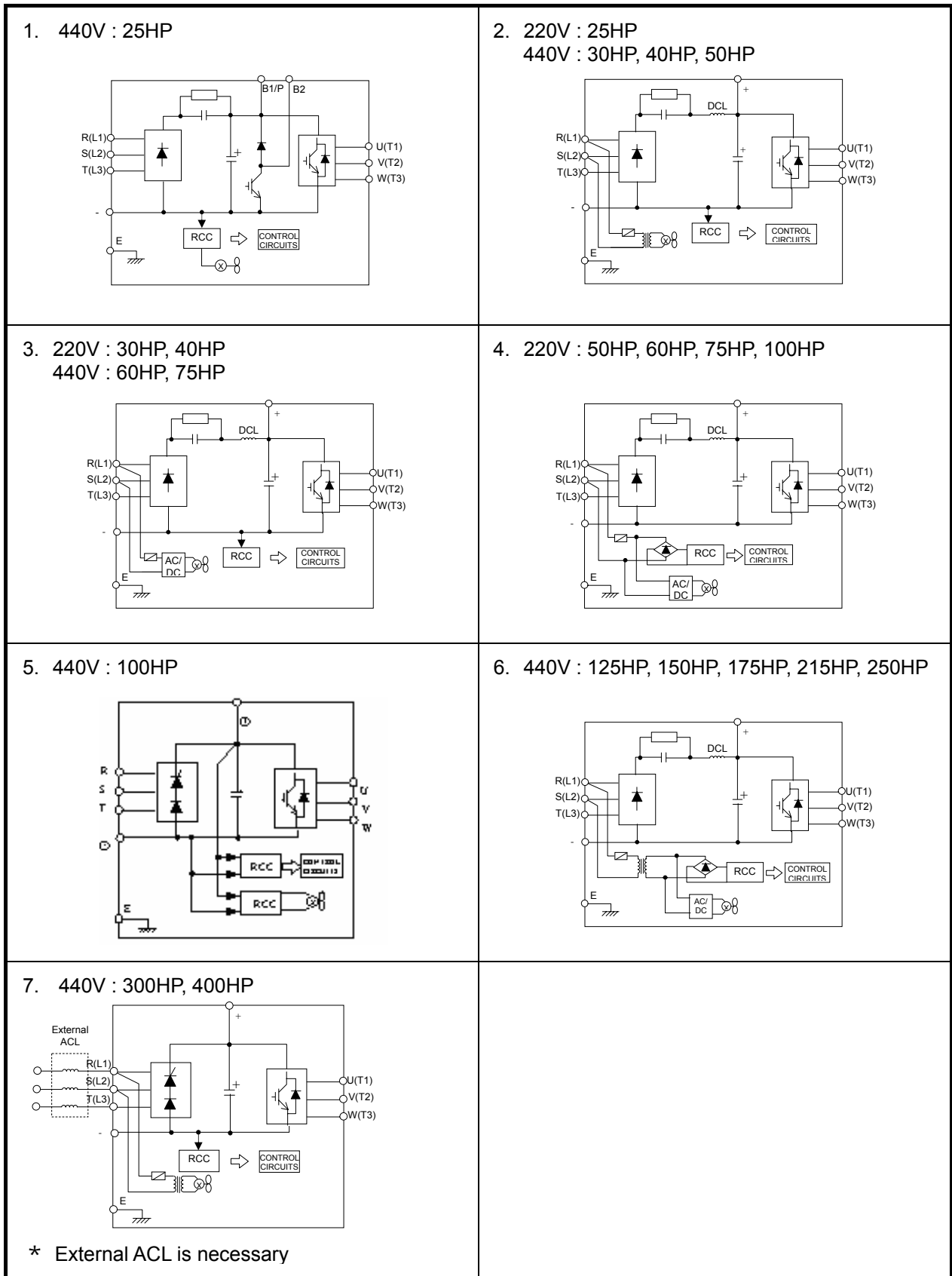

4.4 WIRING PARTS

4.4.1 RECOMMENDED WIRING PARTS

Be sure to connect MCCBs between power supply and 7200GS input terminals L1 (R), L2 (S), L3 (T). Recommended MCCBs are listed in Table 3.

When a ground fault interrupter is used, select the one with no influence for high frequency. The current setting should be 200mA or over and operating time, 0.1 second or over to prevent malfunction.

Table 3. 220V and 440V class applicable wire size and contactor

(a) 220V SERIES

Max. Applicable Motor Output HP (KW) [Note 1]	Cable Size - mm ² (AWG)			Molded-Case Circuit Breaker [Note 4]	Magnetic Contactor [Note 4]
	Power Cable [Note 2]	Ground Cable E [G]	Control Cable [Note 3]		
25(18.5)	22 (4)	14 (6)	0.5~2 (20-14)	TO-225S (150A)	CN-80
30(22)	30 (2)	14 (6)	0.5~2 (20-14)	TO-225S (175A)	CN-100
40(30)	60 (2/0)	22 (4)	0.5~2 (20-14)	TO-225S (175A)	CN-125
50(37)	60×2P (2/0)	22 (4)	0.5~2 (20-14)	TO-225S (200A)	CN-150
60(45)	60×2P (2/0×2P)	22 (4)	0.5~2 (20-14)	TO-225S (225A)	CN-180
75(55)	60×2P (2/0×2P)	30 (2)	0.5~2 (20-14)	TO-400S (300A)	CN-300
100(75)	100×2P (4/0×2P)	50 (1/0)	0.5~2 (20-14)	TO-400S (400A)	CN-300

[Note] 1. For Constant Torque Load.

2. Power Cable Include Cables to the Terminals R (L1), S (L2), T (L3), + , - , BR, U (T1), V (T2), W (T3).
3. Control Cable Include Cables to the Control Terminals.
4. The Molded-Case Circuit Breaker and Magnetic Contactors Shown in Table are TECO Products and are for reference only. Other manufactures' equivalent products may be selected.
5. The Magnetic contactors S-K400 and S-K600 are Mitsubishi Products and are for reference only. Other manufactures' equivalent products may be selected.

(b) 440V SERIES

Max. Applicable Motor Output HP (KW) [Note 1]	Cable Size - mm ² (AWG)			Molded-Case Circuit Breaker [Note 4]	Magnetic Contactor [Note 4]
	Power Cable [Note 2]	Ground Cable E [G]	Control Cable [Note 3]		
25(18.5)	8 (8)	8 (8)	0.5~2 (20-14)	TO-100S (75A)	CN-50
30(22)	14 (6)	8 (8)	0.5~2 (20-14)	TO-100S (100A)	CN-50
40(30)	22 (4)	8 (8)	0.5~2 (20-14)	TO-100S (100A)	CN-65
50(37)	22 (4)	14 (6)	0.5~2 (20-14)	TO-125S (125A)	CN-80
60(45)	38 (1)	14 (6)	0.5~2 (20-14)	TO-225S (175A)	CN-100
75(55)	60 (2/0)	22 (4)	0.5~2 (20-14)	TO-225S (175A)	CN-125
100(75)	60×2P (2/0)	22 (4)	0.5~2 (20-14)	TO-225S (225A)	CN-150
125(90)	60×2P (2/0×2P)	30 (2)	0.5~2 (20-14)	TO-400S (300A)	CN-300
150(110)	60×2P (2/0×2P)	30 (2)	0.5~2 (20-14)	TO-400S (300A)	CN-300
175(132)	100×2P (4/0×2P)	50 (1/0)	0.5~2 (20-14)	TO-400S (400A)	CN-300
215(160)	100×2P (4/0×2P)	50 (1/0)	0.5~2 (20-14)	TO-400S (400A)	CN-300
250(185)	250×2P (2P)	50 (1/0)	0.5~2 (20-14)	TO-600S (600A)	S-K400 [Note 5] (450A)
300(220)	250×2P (2P)	60 (2/0)	0.5~2 (20-14)	TO-800S (800A)	S-K600 (800A)
400(300)	250×2P (2P)	60 (2/0)	0.5~2 (20-14)	TE-1000 (1000A)	S-K600 (800A)

4.4.2 CAUTIONS FOR WIRING



CAUTION

The external interconnection wiring must be performed with the following procedures.

After completing 7200GS interconnections, be sure to check that connections are correct. Never use control circuit buzzer check.

(A) MAIN CIRCUIT INPUT/OUTPUT

- (1) Phase rotation of input terminals L1 (R), L2 (S), L3 (T) is available in either direction. (Clockwise and counterclockwise).
- (2) When inverter output terminals T1 (U), T2 (V), and T3 (W) are connected to motor terminals T1 (U), T2 (V), and T3 (W), respectively, motor rotates counterclockwise. (Viewed from opposite side of drive end, upon forward operation command). To reverse the rotation interchange any two of the motor leads.
- (3) Never connect AC main circuit power supply to output terminals T1 (U), T2 (V), and T3 (W). This may cause damage to the inverter.
- (4) Care should be taken to prevent contact of wiring leads with 7200GS cabinet. If this occurs, a short-circuit may result.
- (5) Never connect power factor correction capacitors or noise filters to 7200GS output.
- (6) Never open or close contactors in the output circuit unless inverter is properly sized.



CAUTION

- Lead size should be determined taking into account voltage drop of leads. Voltage drop can be obtained by the following equation: select such lead size that voltage drop will be within 2% of normal rated voltage.
phase-to-phase voltage drop (V)
$$= \sqrt{3} \times \text{lead resistance } (\Omega / \text{km}) \times \text{wiring distance(m)} \times \text{current(A)} \times 10^{-3} .$$
- Wiring length between inverter and motor.
If total wiring distance between inverter and motor is excessively long and inverter carrier frequency (main transistor switching frequency) is high, harmonic leakage current from the cable will increase to effect the inverter unit or peripheral devices. If the wiring distance between inverter and motor is long, reduce the inverter carrier frequency.

(B) GROUNDING (PE: Protective Earth)

Ground the 7200GS through ground terminal E (PE).

- (1) Ground resistance should be 100 ohms or less.
- (2) Never ground 7200GS in common with welding machines, motors, and other large-current electrical equipment, or ground pole. Run the ground lead in separate conduit from leads for large-current electrical equipment.
- (3) Use the ground leads which comply with AWG standards and make the sure the length is as short as possible.
- (4) Where several 7200GS units are used side by side, it is preferable to ground each unit separately to ground poles. However, connecting all the ground terminals of 7200GS in parallel while grounding only one of the 7200GS's to the ground pole is also permissible (Fig. 3). Be sure not to form a loop with the ground leads.

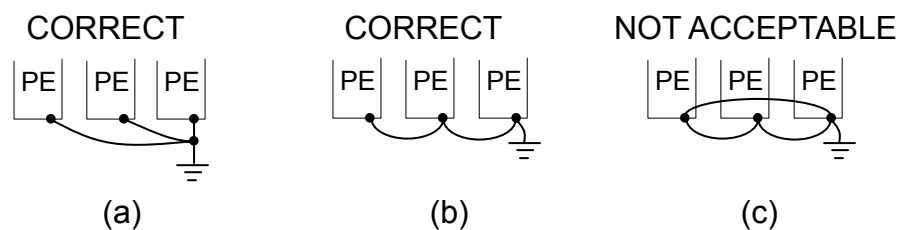

Fig. 3 Grounding of Three 7200GS Units

(C) CONTROL CIRCUIT

- (1) Separation of control circuit leads and main circuit leads: All signal leads must be separated from main circuit leads L1 (R), L2 (S), L3 (T), +, -, B2, T1 (U), T2 (V), T3 (W) and other power cables to prevent erroneous operation caused by noise interference.
- (2) Control circuit leads 9, 10, 18, 19, 20 (contact output) must be separated from leads 1 to 8, 21, 22, 25, 26, 27 and 11, 17.
- (3) Use twisted shielded or twisted pair shielded wire for the control circuit line and connect the shield sheath to the inverter terminal E to prevent malfunction caused by noise. See Fig.4. Wiring distance should be less than 164ft (50m).

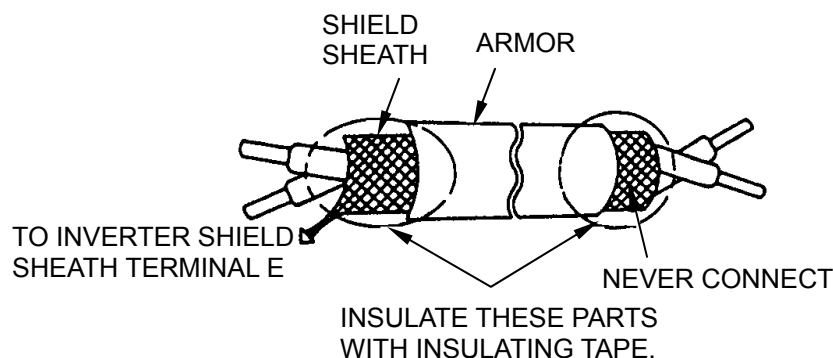

Fig. 4 Shielded Wire Termination

4.4.3 Fuse types

Drive input fuses are provided to disconnect the drive from power in the event that a component fails in the drive's power circuitry. The drive's electronic protection circuitry is designed to clear drive output short circuits and ground faults without blowing the drive input fuses. Below table shows the 7200GS input fuse ratings.

To protect the inverter most effectively, use fuses with current-limit function.

220V class

MODEL	HP	KVA	100% CONT. Output AMPS	Rated Input AMPS	FUSE Rating
JNTEBG 7R50JK	7.5	10.3	24	29	50
JNTEBG 0010JK	10	13.7	32	38	60
JNTEBG 0015JK	15	20.6	48	58	100
JNTEBG 0020JK	20	27.4	64	77	125
JNTEBG 0025JK	25	34	80	88	125
JNTEBG 0030JK	30	41	96	106	150
JNTEBG 0040JK	40	54	130	143	200
JNTEBG 0050JK	50	57	160	176	250
JNTEBG 0060JK	60	67	183	201	300
JNTEBG 0075JK	75	85	224	246	350
JNTEBG 0100JK	100	128	300	330	450

440V class

MODEL	HP	KVA	100% CONT. Output AMPS	Rated Input AMPS	FUSE Rating
JNTEBG 7R50AZ	7.5	10.3	12	14	25
JNTEBG 0010AZ	10	13.7	16	19	30
JNTEBG 0015AZ	15	20.6	24	29	50
JNTEBG 0020AZ	20	27.4	32	38	60
JNTEBG 0025AZ	25	34	40	48	70
JNTEBG 0030AZ	30	41	48	53	80
JNTEBG 0040AZ	40	54	64	70	100
JNTEBG 0050AZ	50	68	80	88	125
JNTEBG 0060AZ	60	82	96	106	150
JNTEBG 0075AZ	75	110	128	141	200
JNTEBG 0100AZ	100	138	165	182	250
JNTEBG 0125AZ	125	180	192	211	300
JNTEBG 0150AZ	150	195	224	246	350
JNTEBG 0175AZ	175	230	270	297	400
JNTEBG 0215AZ	215	260	300	330	450
JNTEBG 0250AZ	250	290	340	374	500
JNTEBG 0300AZ	300	385	450	540	700
JNTEBG 0400AZ	400	513	600	720	900

Fuse Type UL designated SEMICONDUCTOR PROTECTION FUSES

Class CC, J, T, RK1 or RK5

Voltage Range: 300V for drives with 230V class VFD

500V for drives with 460V class VFD

5. TEST OPERATION

To assure safety, prior to test operation, disconnect the coupling or belt which connects the motor with the machine so that motor operation is isolated. If an operation must be performed while the motor is directly connected to the machine, use great care to avoid any possible hazardous condition.

5.1 CHECK BEFORE TEST OPERATION

After completion of installation and wiring, check for

- (1) proper wiring
- (2) short-circuit due to wire clippings
- (3) loose screw-type terminals
- (4) proper load

5.2 SETTING THE LINE VOLTAGE SELECTING CONNECTOR FOR 460V CLASS 30HP (22kW) AND ABOVE

The cooling fan line voltage selecting connector shown in Fig. 5 must be set according to the type of main circuit power supply. Insert the connector at the position showing the appropriate line voltage.

The unit is preset at the factory to 440 line voltage.

- (a) 440V CLASS: 30HP ~ 75HP
300HP ~ 400HP

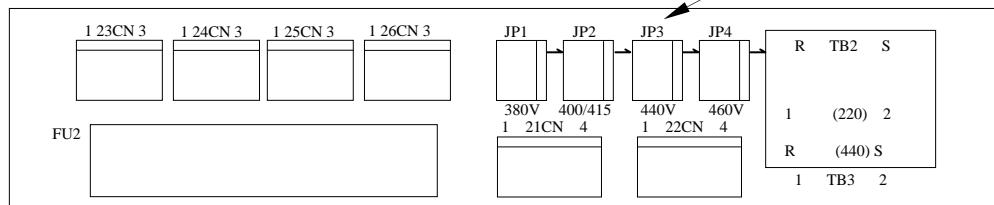

- (b) 440V CLASS: 100HP ~ 250HP

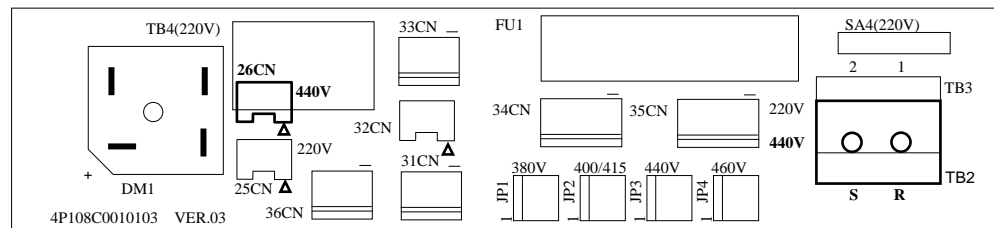

Fig. 5 Voltage Selecting Connector

6. MAINTENANCE

6.1 PERIODIC INSPECTION

The 7200GS requires very few routine checks. It will function longer if it is kept clean, cool and dry. Observe precautions listed in "Location". Check for tightness of electrical connections, discoloration or other signs of overheating. Use Table 4 as your inspection guide. Before servicing, turn OFF AC main circuit power and be sure that CHARGE lamp is OFF.

Table 4 Periodic Inspection

Component	Check	Corrective Action
External terminals, unit mounting bolts, connectors, etc.	Loose screws	Tighten
	Loose connectors	Tighten
Cooling fins	Build-up of dust and dirt	Blow with dry compressed air of 39.2×10^4 to 58.8×10^4 Pa (57 to 85psi.) pressure.
Printed circuit board	Accumulation of conductive dust or oil	Blow with dry compressed air of 39.2×10^4 to 58.8×10^4 Pa (57 to 85psi.) pressure. If dust and oil cannot be removed, replace the board.
Cooling fan	Abnormal noise and vibration. Whether the cumulative operation time exceeds 20,000 hours or not.	Replace the cooling fan.
Power elements	Accumulation of dust and dirt	Blow with dry compressed air of 39.2×10^4 to 58.8×10^4 Pa (57 to 85psi) pressure.
Smoothing capacitor	Discoloration or odor	Replace the capacitor or inverter unit.

Note: Operating conditions as follows:

- Ambient temperature: Yearly average 30 , 86
- Load factor: 80% or less
- Operating time: 12 hours or less per day

Standard Parts Replacement

Item Name	Replacement Cycle	Remarks
Cooling fan	2 or 3 years	Replace with a new product.
Smoothing capacitor	5 years	Replace with a new product. (Determine after examination).
Circuit Breakers and relays	-	Determine after examination.
Fuse	10 years	Replace with a new product.
Aluminum capacitor on PC board	5 years	Replace with a new product. (Determine after examination).

Note: Operating conditions as follows:

- Ambient temperature: Yearly average 30 , 86
- Load factor: 80% or less
- Operating time: 20 hours or less per day

6.2 SPARE PARTS

As insurance against costly downtime, it is strongly recommended that renewal parts be kept on hand in accordance with the table below. When ordering renewal parts, please specify to your local distributor or TECO representative the following information: Part Name, Part Code No. and Quantity.

Table 5 Spare Parts for 220V Class

INVERTER & PARTS NAME		Control PC Board*	Power Board	Main Circuit Transistor	Main Circuit Diode	Cooling Fan
HP	SPEC					
25	MODEL	-	-	CM200DU-12H	DF200BA080	4E-230B
	CODE	4H300D4820002	3P106C0670008	277810212	277192187	3M903D0450004
	Qty	1	1	3	1	2
30	MODEL	-	-	CM200DU-12F	DF200BA080	4E-230B
	CODE	4H300D4820002	4P106C02900B1	277810255	277192187	3M903D0450004
	Qty	1	1	3	1	2
40	MODEL	-	-	CM300HA-12H	2R160E-080	4E-230B
	CODE	4H300D4820002	3P106C06400D4	3H324D0460000	277051532	3M903D0450004
	Qty	1	1	6	6	3
50	MODEL	-	-	CM400HA-12H	2R160E-080	4E-230B
	CODE	4H300D4820002	3P106C06400E2	277800179	277051532	3M903D0450004
	Qty	1	1	6	6	3
60	MODEL	-	-	1MBI600NP-060	2R160E-080	4E-230B
	CODE	4H300D4820002	3P106C06400F1	277800195	277051532	3M903D0450004
	Qty	1	1	6	6	3
75	MODEL	-	-	1MBI600NP-060	2R160E-080	4E-230B
	CODE	4H300D4820002	3P106C06400G9	277800195	277051532	3M903D0450004
	Qty	1	1	6	6	3
100	MODEL	-	-	CM300HA-12H	2R1100E-080	S175-2-HWB
	CODE	4H300D4820002	3P106C06400H7	3H324D0460000	277051516	279152115
	Qty	1	1	12	6	3

Table 6 Spare Parts for 440V Class

INVERTER & PART NAME		Control PC Board*	Power Board	Main Circuit Transistor	Main Circuit Diode	Cooling Fan	
HP	SPEC						
25	MODEL	-	-	7MBP075RA120	DF75LA160	AFB0824SH-B	-
	CODE	4H300D4820002	3P106C06500C1	277831538	277192195	4H300D1050001	-
	Qty	1	1	1	1	2	-
30	MODEL	-	-	CM100DU-24F	DF75LA160	A2123-HBT	ASB0624H-B
	CODE	4H300D4820002	4P106C02900A2	277810280	277192195	4M903D1890001	4H300D1060007
	Qty	1	1	3	1	2	1
40	MODEL	-	-	CM150DU-24F	DF100LA160	A2123-HBT	ASB0624H-B
	CODE	4H300D4820002	4P106C02900A2	277810298	277192217	4M903D1890001	4H300D1060007
	Qty	1	1	3	1	2	1
50	MODEL	-	-	CM200DU-24F	2U/DDB6U145N16L	A2123-HBT	ASB0624H-B
	CODE	4H300D4820002	4P106C02900A2	277810301	277190222	4M903D1890001	4H300D1060007
	Qty	1	1	3	1	2	1
60	MODEL	-	-	CM200DU-24F	2U/DDB6U145N16L	AFB1224SHE	AFB0824SH-B
	CODE	4H300D4820002	4P106C02900A2	277810301	277190222	4M903D1880006	4H300D1440004
	Qty	1	1	3	1	2	1
75	MODEL	-	-	CM300DU-24F	2U/DDB6U205N16L	AFB1224SHE	AFB0824SH-B
	CODE	4H300D4820002	4P106C02900A2	277810310	277190249	4M903D1880006	4H300D1440004
	Qty	1	1	3	1	2	1
100	MODEL	-	-	SKM400GB128D	SKKH106/16E	FFB1224EHE	ASB0624H-B
	CODE	4H300D4820002	4P106C02900D7	277810611	277112302	4H300D5110009	4H300D1060007
	Qty	1	1	3	3	2	1
125	MODEL	-	-	CM600HU-24F	2RI100G-160	AFB1224SHE	A2123-HBT
	CODE	4H300D4820002	4P106C02700A1	277800225	277051524	4M903D1880006	4M903D1890001
	Qty	1	1	6	6	3	1
150	MODEL	-	-	CM600HU-24F	2RI100G-160	AFB1224SHE	A2123-HBT
	CODE	4H300D4820002	4P106C02700A1	277800225	277051524	4M903D1880006	4M903D1890001
	Qty	1	1	6	6	3	1
175	MODEL	-	-	CM600HU-24F	2RI100G-160	AFB1224SHE	A2123-HBT
	CODE	4H300D4820002	4P106C02700A1	277800225	277051524	4M903D1880006	4M903D1890001
	Qty	1	1	6	6	3	1
215	MODEL	-	-	CM400HU-24F	2RI100G-160	EFB1524HHG	A2123-HBT
	CODE	4H300D4820002	4P106C02700A1	277800217	277051524	4M300D3680002	4M903D1890001
	Qty	1	1	12	6	3	1
250	MODEL	-	-	CM400HU-24F	2RI100G-160	EFB1524HHG	A2123-HBT
	CODE	4H300D4820002	4P106C02700A1	277800217	277051524	4M300D3680002	4M903D1890001
	Qty	1	1	12	6	3	1
300	MODEL	-	-	Skiip1203GB122-2DL	SKKH500/E16	2RRE45250 * 56R	-
	CODE	4H300D4820002	3P106C0060009	4M903D2030006	4M903D2000000	4M903D1940009	-
	Qty	1	1	3	3	2	-
400	MODEL	-	-	Skiip1513GB122-2DL	SKKH500/E16	2RRE45250 * 56R	-
	CODE	4H300D4820002	3P106C0060009	4M903D2040001	4M903D2000000	4M903D1940009	-
	Qty	1	1	3	3	2	-

7. SPECIFICATIONS

- Basic Specifications

220V CLASS

INVERTER (HP)		25	30	40	50	60	75	100
MAX. APPLICABLE MOTOR OUTPUT HP (KW)*1		25 (18.5)	30 (22)	40 (30)	50 (37)	60 (45)	75 (55)	100 (75)
Output Characteristics	Inverter Capacity (KVA)	34	41	54	57	67	85	128
	Rated Output Current (A)	80	96	130	160	183	224	300
	Max. Output Frequency	3-Phase, 200~240V (Proportional to input voltage)						
	Rated Output Frequency	Up to 400Hz available						
Power Supply	Rated Input Voltage And Frequency	3-Phase, 200~240V, 50Hz 200/208/220/230V, 60Hz						
	Allowable Voltage Fluctuation	+10% ~ -15%						
	Allowable Frequency Fluctuation	±5%						

440V CLASS

INVERTER (HP)		25	30	40	50	60	75	100	125	150	175	215	250	300	400
MAX. APPLICABLE MOTOR OUTPUT HP (KW)*1		25 (18.5)	30 (22)	40 (30)	50 (37)	60 (45)	75 (55)	100 (75)	125 (90)	150 (110)	175 (132)	215 (160)	250 (185)	300 (220)	400 (300)
Output Characteristics	Inverter Capacity (KVA)	34	41	54	68	82	110	138	180	195	230	260	290	385	513
	Rated Output Current (A)	40	48	64	80	96	128	165	192	224	270	300	340	450	600
	Max. Output Frequency	3-Phase, 380~480V (Proportional to input voltage)													
	Rated Output Frequency	Up to 400Hz available													
Power Supply	Rated Input Voltage And Frequency	3-Phase, 380~480V, 50/60Hz													
	Allowable Voltage Fluctuation	+10% ~ -15%													
	Allowable Frequency Fluctuation	±5%													

* 1 Based on 4 pole motor

CHARACTERISTICS

Control Characteristics	Control Method	<ul style="list-style-type: none"> ● Sine wave PWM ● Four control modes (switched by parameter) <ul style="list-style-type: none"> - V/F control - Sensorless vector control (With Auto-tuning) - PID&Auto Energy Saving control - V/F+PG control
	Starting Torque	<ul style="list-style-type: none"> ● V/F control: 150% at 3Hz ● Sensorless Vector control: 150% at 1Hz
	Speed Control Range	<ul style="list-style-type: none"> ● V/F control: 1 : 10 ● Sensorless Vector control: 1 : 60
	Speed Response	5Hz (Sensorless Vector)
	Speed Control Accuracy	<ul style="list-style-type: none"> ● V/F control: ±1% (with slip compensation) ● V/F + PG Control : ±0.03% ● Sensorless Vector control: ±0.5%
	Frequency Control Range	0.1 ~ 400.0Hz
	Frequency Setting Resolution	Digital reference: 0.01Hz (100Hz Below); Analog reference: 0.06Hz/60Hz
	Frequency Accuracy	Digital reference: ±0.01% (-10 ~ +40); Analog command: ±0.1% (25 ± 10)
	Output Frequency Resolution	0.01Hz (1/30000)
	Frequency Setting Signal	0 ~ 10VDC (20KΩ), 4~20mA (250Ω)
	Overload Capacity	150% rated output current for 1 minute.
	Accel/Decel Time	0.1 ~ 6000.0 sec (Accel/Decel time settings independently)
	Efficiency at Rated Freq.	0.95 above
	Braking Torque	Approx. 20% (Approx. 125% When using braking resistor) Inverter of 220V 20HP (15KW) or less and 440V 25HP (18.5KW) or less have a Built-in braking transistor
Protective Functions	Motor Overload Protection	Electric thermal overload relay
	Instantaneous Overcurrent (OC) and Short Circuit Protection	Motor coasts to stop at approx. 200% rated output current.
	Inverter Overheat Protection (OL2)	150% inverter rated output current for 1 min.
	Overvoltage (OV)	Motor coasts to stop if the main circuit voltage exceeds 410VDC (820VDC for 440V class)
	Undervoltage (UV)	Motor coasts to stop if the main circuit voltage drops to 190VDC (380VDC for 440V class)
	Momentary Power Loss	Immediately stop after 15 ms or longer power loss (at factory setting) Continuous operation during power loss less than 2 sec. (standard)
	Fin Overheat (OH)	Thermostat
	Stall Prevention	Stall prevention during acceleration/deceleration and constant speed operation.
	Ground Fault (GF)	Provided by electronic circuit.
	Power Charge Indication	Indicates until main circuit voltage reaches 50V.
Environmental Conditions	Location	Indoor (Protected from corrosive gases and dust)
	Humidity	95% RH (non-condensing)
	Storage Temperature	-20 ~+60 (for short period during shipping)
	Ambient Temperature	-10 to +40 (for NEMA1 type); -10 to +45 (for open chassis type)
	Altitude	1000m or below
	Vibration	9.8m/s ² at 20Hz or below, up to 2m/s ² at 20 to 50Hz
Communication Function	MODBUS, PROFIBUS (option)	
EMI	Meet EN 50081-2 (1994) with specified EMI filter	
EMC Compatibility	Meet Pr EN50082-2	

(b) 220V : 25HP 100HP
 440V : 30HP 250HP

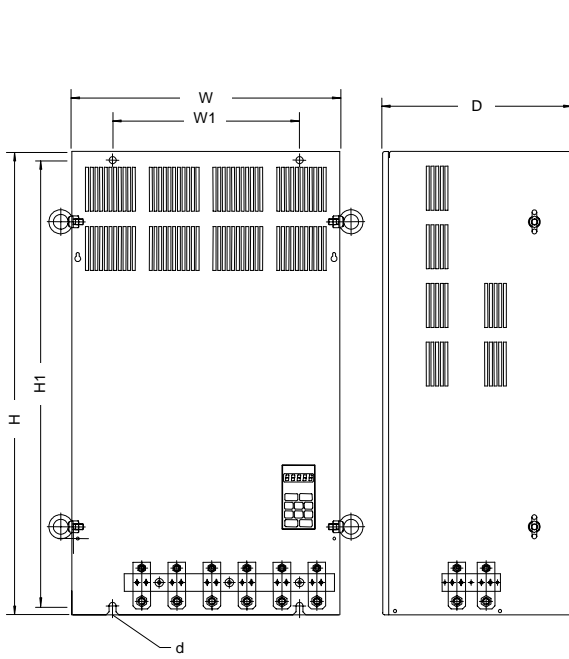

(Open Chassis Type - IP00)

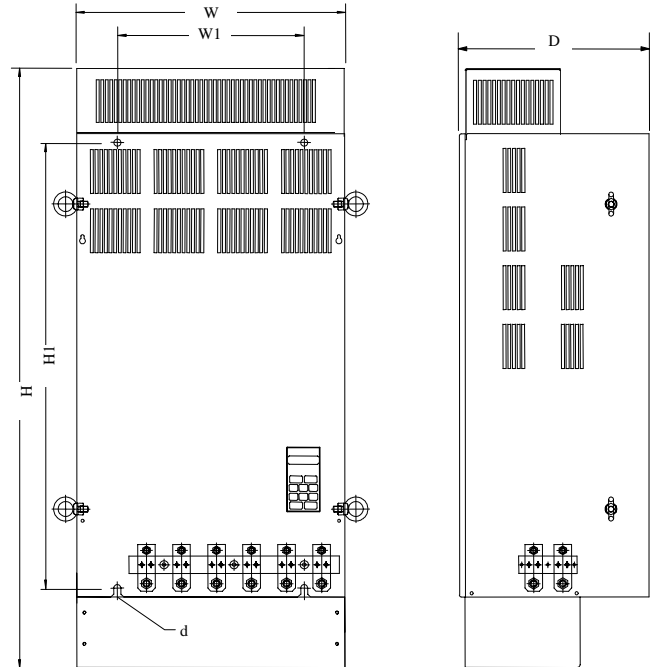

(Wall-mounted Type - NEMA1)

(d) 440V : 300HP, 400HP

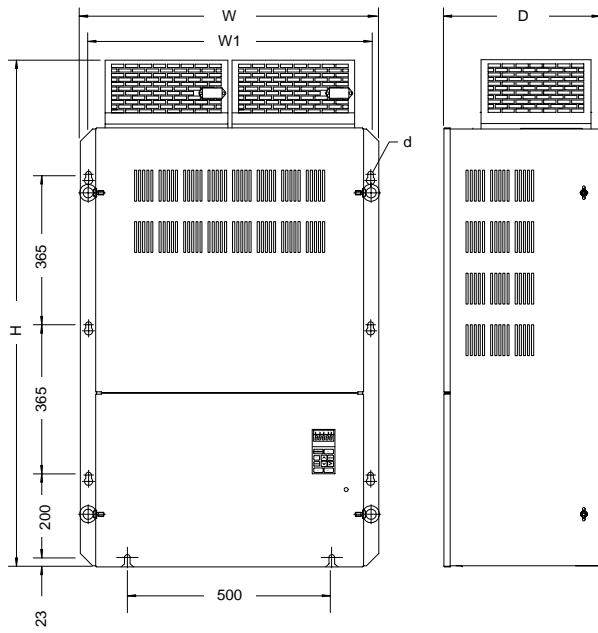

(Open Chassis Type - IP00)

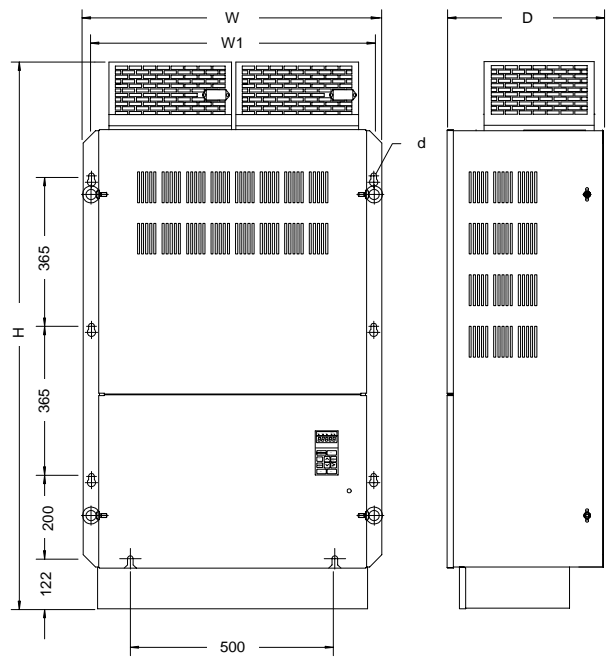

(Wall-mounted Type - NEMA1)

9. PERIPHERAL AND OPTIONS

9.1 AC REACTOR

- When power capacity is significantly large compared to inverter capacity, or when the power factor needs to be improved, externally connect an AC reactor.
- 7200GS 220V 25 ~ 100HP and 440V 30 ~ 250HP have built-in DC reactor as standard. (When the power factor needs to be improved, externally connect an AC reactor).
- 440V 25HP connects an optional AC reactor When the power factor needs to be improved.
- 440V 300 ~ 400HP need to connect an AC reactor externally.

Table 8 AC REACTOR

Voltage	Inverter		AC Reactor	
	HP	Rated current (A)	Current (A)	Inductance (mH)
220V	25	80	90	0.12
	30	96	120	0.09
	40	130	160	0.07
	50	160	200	0.05
	60	183	240	0.044
	75	224	280	0.038
	100	300	360	0.026
440V	25	40	50	0.42
	30	48	60	0.36
	40	64	80	0.26
	50	80	90	0.24
	60	96	120	0.18
	75	128	150	0.15
	100	169	200	0.11
	125	192	200	0.11
	150	224	250	0.09
	175	270	330	0.06
	215	300	330	0.06
	250	340	400	0.05
	300	450	500	0.04
400	600	670	0.032	

9.2 NOISE FILTER

9.2.1 INPUT NOISE FILTER

- When input noise filter is installed as indicated, the 7200GS will comply with the EN61800-3 noise interference suppression directive.

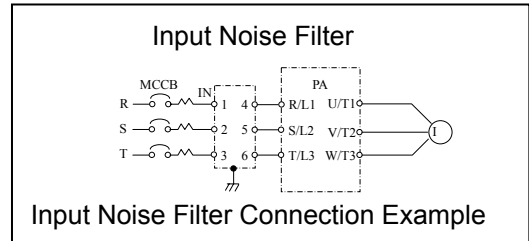
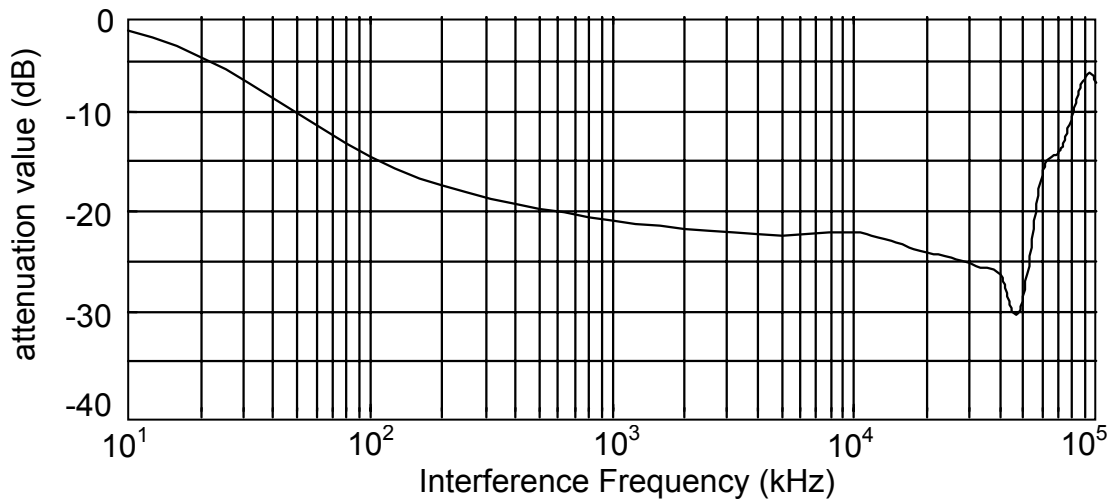

Table 9 Input Noise Filter

Inverter			Input Noise Filter	
Voltage (V)	HP	Rated current (A)	Model NO.	Rated current (A)
220V	25	80A	FS6100-90-34	90A
	30	96A	FS6100-150-40	150A
	40	130A	FS6100-150-40	150A
	50	160A	FS6100-250-99	250A
	60	183A	FS6100-250-99	250A
	75	224A	FS6100-400-99	400A
	100	300A	FS6100-400-99	400A
440V	25	40A	FS6101-50-52	50A
	30	48A	FS6101-80-52	80A
	40	64A	FS6101-80-52	80A
	50	80A	FS6101-120-35	120A
	60	96A	FS6101-120-35	120A
	75	128A	FS6101-200-40	200A
	100	165A	FS6101-200-40	200A
	125	192A	FS6101-320-99	320A
	150	224A	FS6101-320-99	320A
	175	270A	FS6101-320-99	320A
	215	300A	FS6101-400-99-1	400A
	250	340A	FS6101-400-99-1	400A
	300	450A	FS6101-600-99	600A
400	600A	FS6101-800-99	800A	

9.2.2 EMI SUPPRESSION ZERO CORE

- Model: JUNFOC046S - - - - -
- Code No.: 4H000D0250001
- According to the required power rating and wire size, select the matched ferrite core to suppress the zero sequence EMI filter.
- The ferrite core can attenuate the frequency response at high frequency range (from 100KHz to 50MHz, as shown below). It should be able to attenuate the RFI from inverter to outside.
- The zero-sequence noise filter ferrite core can be installed either on the input side or on the output side. The wire around the core for each phase should be wound by following the same convention and one direction. The more winding turns the better attenuation effect. (Without saturation). If the wire size is too big to be wound, all the wire can be grouped and go through these several cores together in one direction.
- Frequency attenuation characteristics (10 windings case)



Example: EMI suppression zero core application example

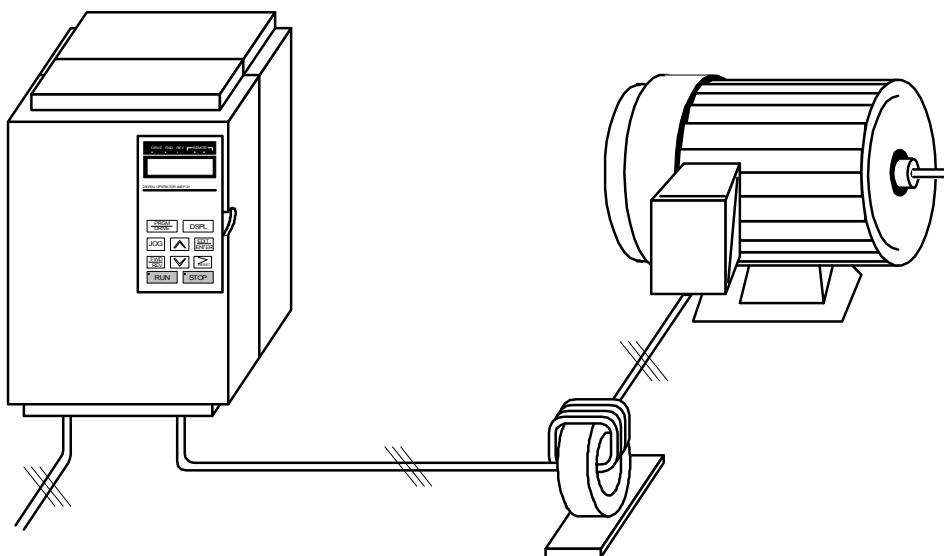

Note: All the line wire of U/T1, V/T2, W/T3 phase must pass through the same zero-phase core in the same winding sense.

9.3 BRAKING RESISTOR AND BRAKING UNIT

- The braking transistor of 440V 25HP was built-in as standard, the braking resistor can be connected to main circuit terminals B2 and + directly. The others without built-in braking transistor need to connect braking unit with braking resistor externally.
- When connecting braking resistor or braking unit with braking resistor, set system parameter Sn-10=XX1X (i.e. stall prevention during deceleration not enabled).
- Braking resistor and braking unit selection table is shown below.

Table 10 Braking Resistor and Braking Unit

Inverter			Braking Unit		Braking Resistor			Braking Torque (%)
Voltage	HP	Rated current (A)	MODEL NO.	Number used	MODEL NO.	Specs.	Number used	
220V	25	80A	JNTBU-230	1	JNBR-4R8KW8	4800W/8Ω	1	119%(10%ED)
	30	96A	JNTBU-230	1	JNBR-4R8KW6R8	4800W/6.8Ω	1	117%(10%ED)
	40	130A	JNTBU-230	2	JNBR-3KW10	3000W/10Ω	2	119%(10%ED)
	50	160A	JNTBU-230	2	JNBR-3KW10	3000W/10Ω	2	99%(10%ED)
	60	183A	JNTBU-230	2	JNBR-4R8KW6R8	4800W/6.8Ω	2	117%(10%ED)
	75	224A	JNTBU-230	3	JNBR-4R8KW6R8	4800W/6.8Ω	2	98%(10%ED)
	100	300A	JNTBU-230	3	JNBR-4R8KW6R8	4800W/6.8Ω	3	108%(10%ED)
440V	25	40A	-	-	JNBR-1R6KW50	1600W/50Ω	1	84%(10%ED)
	30	48A	JNTBU-430	1	JNBR-4R8KW27R2	4800W/27.2Ω	1	117%(10%ED)
	40	64A	JNTBU-430	1	JNBR-6KW20	6000W/20Ω	1	119%(10%ED)
	50	80A	JNTBU-430	2	JNBR-4R8KW32	4800W/32Ω	2	119%(10%ED)
	60	96A	JNTBU-430	2	JNBR-4R8KW27R2	4800W/27.2Ω	2	117%(10%ED)
	75	128A	JNTBU-430	2	JNBR-6KW20	6000W/20Ω	2	126%(10%ED)
	100	165A	JNTBU-430	3	JNBR-6KW20	6000W/20Ω	3	139%(10%ED)
	125	192A	JNTBU-430	3	JNBR-6KW20	6000W/20Ω	3	115%(10%ED)
	150	224A	JNTBU-430	3	JNBR-6KW20	6000W/20Ω	3	99%(10%ED)
	175	270A	JNTBU-430	5	JNBR-6KW20	6000W/20Ω	5	134%(10%ED)
	215	300A	JNTBU-430	6	JNBR-6KW20	6000W/20Ω	6	131%(10%ED)
	250	340A	JNTBU-430	6	JNBR-6KW20	6000W/20Ω	6	115%(10%ED)
	300	450A	JNTBU-430	6	JNBR-6KW20	6000W/20Ω	6	99%(10%ED)
400	600A	JNTBU-430	9	JNBR-6KW20	6000W/20Ω	9	109%(10%ED)	

Note: Another choices are listed as below. (JUVPHV-0060 no UL certification.)

440V 50HP : (JUVPHV-0060+JNBR-9R6KW16)x1

440V 60HP : (JUVPHV-0060+JNBR-9R6KW13R6)x1

440V 125HP : (JUVPHV-0060+JNBR-9R6KW13R6)x2

440V 215HP : (JUVPHV-0060+JNBR-9R6KW13R6)x4

440V 300HP : (JUVPHV-0060+JNBR-9R6KW13R6)x5

440V 100HP : (JUVPHV-0060+JNBR-9R6KW13R6)x2

440V 175HP : (JUVPHV-0060+JNBR-9R6KW13R6)x3

440V 250HP : (JUVPHV-0060+JNBR-9R6KW13R6)x4

440V 400HP : (JUVPHV-0060+JNBR-9R6KW13R6)x6

9.4 OTHERS

9.4.1 DIGITAL OPERATOR WITH EXTENSION WIRE

- Used for the operation of LCD (or LED) digital operator or monitor when removed from the front of inverter unit.

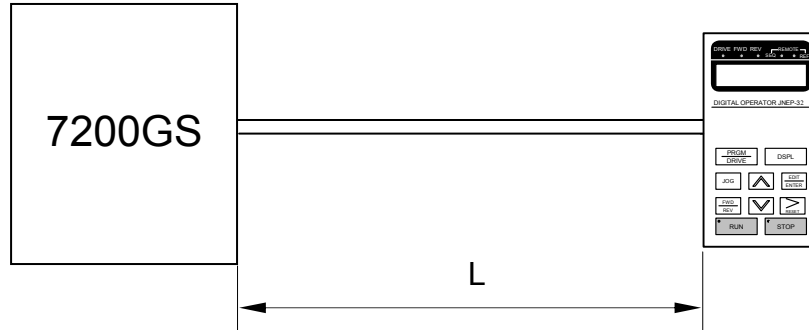

Cable Length	Extension Cable Set*1	Extension Cable Set*2	Blank Cover*3
1m	4H332D0010000	4H314C0010003	4H300D1120000
2m	4H332D0030001	4H314C0030004	
3m	4H332D0020005	4H314C0020009	
5m	4H332D0040006	4H314C0040000	
10m	4H332D0130005	4H314C0060001	

*1 : Including special cable for LCD (or LED) operator, blank cover, fixed use screws and installation manual.

*2 : One special cable for digital operator.

*3 : A blank cover to protect against external dusts, metallic powder, etc.

- The physical dimension of LCD (or LED) digital operator is drawn below.

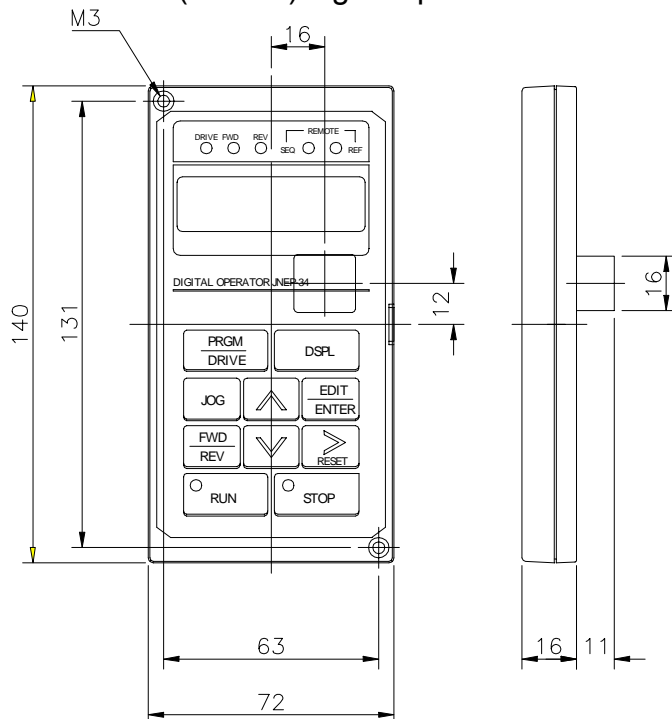

Fig. 6 LCD Digital Operator Dimension

9.4.2 ANALOG OPERATOR

All 7200GS have the LCD (or LED) digital operator. Moreover, an analog operator as JNEP-16 (shown in fig. 7) is also available and can be connected through wire as a portable operator. The wiring diagram is shown below.

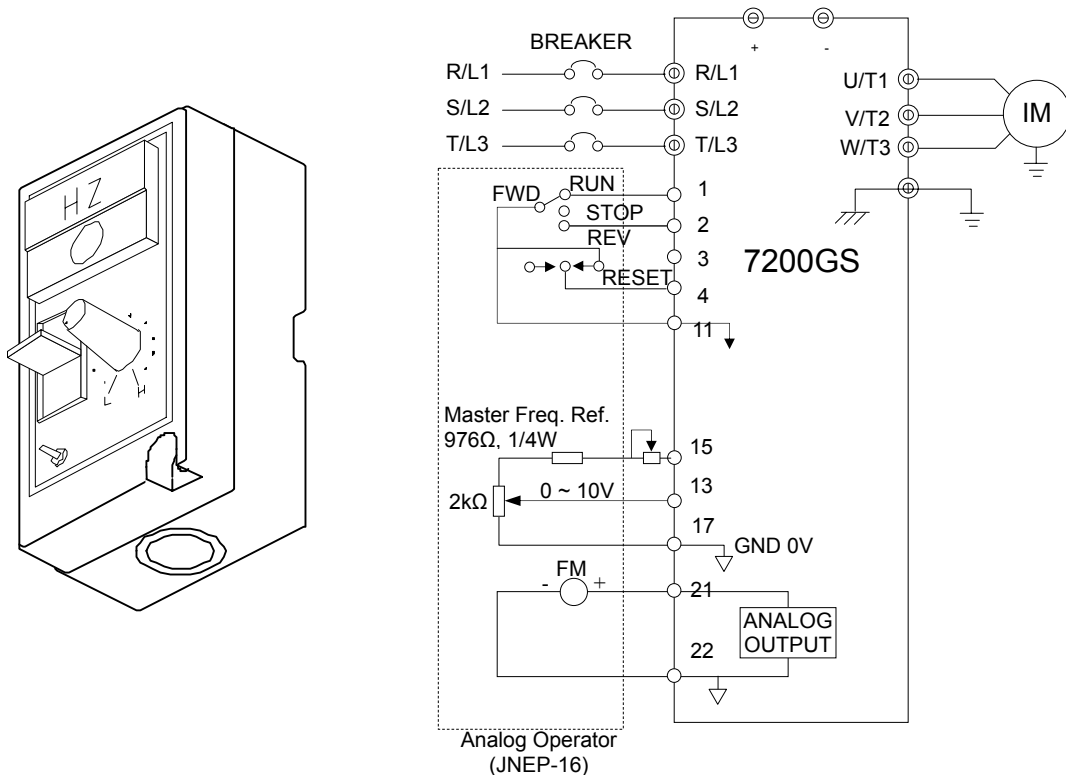

Fig. 7 Analog Operator

9.4.3 LED DIGITAL OPERATOR

- All 7200GS have standard with LCD digital operator (JNEP-34). Moreover, an LED digital operator JNEP-33 (shown in Fig. 10) is also available and can be connected through the same cable and connector.
- The LED digital operator has the same installation and dimension with the LCD digital operator.

9.4.4 OPTION CARDS

: Valid
: Invalid

Name	Code No.	Descriptions	Valid Access Levels				Install Location
			GP	SL	PID	PG	
RS-485 Communication Card SI-M	4H300D4560001	MODBUS RTU protocol communication optional card: <ul style="list-style-type: none"> ● Communication method: Asynchronous ● Communication speed: 19.2Kbps (max.) ● Interface: RS-232, RS-422, RS-485 					2CN
PG Speed Controller Card FB-C	3H300D1180009	Permits compensation of speed variation caused by slip, by speed feedback using a pulse generator (PG) provided to the motor: <ul style="list-style-type: none"> ● Phase A (signal pulse) input. ● PG frequency range: 50 to 65535Hz ● Pulse monitor output: +12V, 20mA ● Input Voltage: +12V ● Input current: 300mA } External supply					3CN
Digital pulse monitor Card PM-C	3H331C0060008	Outputs pulse train signal corresponding to the inverter output frequency <ul style="list-style-type: none"> ● Output pulse: 1F, 6F, 10F, 12F, 36F (F: output frequency) ● Output voltage: +12V ±10% (isolated) ● Output current: 20mA max 					3CN
Analog monitor Card AO-12	4H300D3850005	Output analog signal for monitoring inverter output state (output frequency, output current etc.) <ul style="list-style-type: none"> ● Output resolution: 11 bits (1/2048) ● Output voltage: -10 to +10V (non isolated) ● Output channel: 2 channels 					3CN
Digital reference Card DI-08	4H300D4570006	Allows 8 bits digital speed reference set. <ul style="list-style-type: none"> ● Input signal: binary 8 bits/BCD 2 digits + code ● Input voltage: +24V (isolated) ● Input current: 8mA 					2CN
Analog reference Card AI-14B	4H300D4580001	Allows bipolar high precision, high resolution analog speed reference set. <ul style="list-style-type: none"> ● Input signal level: 0 to ±10VDC (20KΩ) 4 to 20mA (250Ω) 3 channels ● Input resolution: 13 bits + code (1/8192) 					2CN

Name	Code No.	Descriptions	Valid Access Levels				Install Location
			GP	SL	PID	PG	
V/I Conversion card V/I card	3P103D0280001	Converts the multi-function analog output (terminals 21 - 22) signal from 0~10V to 4~20mA signal					3CN
Digital output card DO-08		Outputs isolated type digital signal for monitoring inverter run state (alarm signal, zero speed detection etc.) <ul style="list-style-type: none"> ● Output channel: Photo coupler 6 channels (48V, 50mA or less) { Relay contact output 2 channels } 250VAC, 1A or less 30VDC, 1A or less 					3CN
PROFIBUS Communication card GS-P		PROFIBUS protocol communication optional card: <ul style="list-style-type: none"> ● Communication method: Asynchronous ● Communication speed: 19.2Kbps (max.) ● Interface: RS-232, RS-422, RS-485 					2CN

【Installation】 Use the following procedure to install these option card.

- 1>. Turn off the main circuit power supply.
- 2>. Leave it off for a least one minute before removing the front cover of the inverter. Check to be sure that the CHARGE indicator is OFF.
- 3>. Insert the spacer (Which is provided with the option card) into the spacer hole at the control board.
- 4>. Pass the spacer through the spacer hole at the option card. Check to be sure that it is precisely aligned with the 2CN or 3CN position, and snap it into the proper position.
- 5> 2CN port and 1CN port are used at the same time by GS-P, so can't be work when GS-P is used.

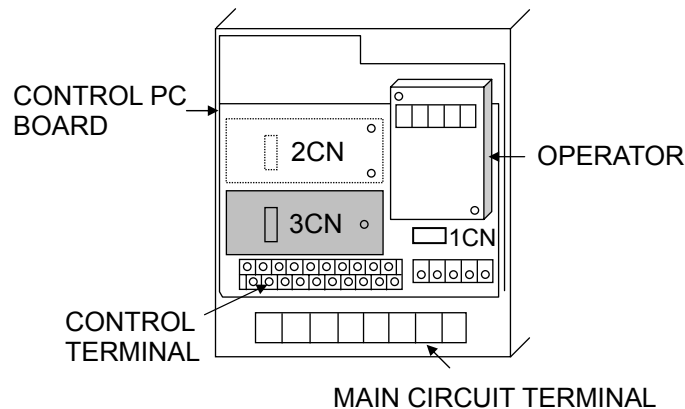

Fig. 8 Option card Installation



PART II

OPERATION MANUAL

1. DESCRIPTION OF USING 7200GS

1.1 Using LCD (or LED) digital operator

- 7200GS are standard with LCD digital operator JNEP-34. Moreover, an LED digital operator JNEP-33 is also available. Three two digital operator have the same operation functions except the LCD and 7-segments LED display difference.
- The LCD and LED digital operator has 2 modes: DRIVE mode and PRGM mode. When the inverter is stopped, DRIVE mode or PRGM mode can be selected by pressing the key . In DRIVE mode, the operation is enabled. Instead, in the PRGM mode, the parameter settings for operation can be changed but the operation is not enabled.

a> The LCD digital operator component names and functions shown as below:

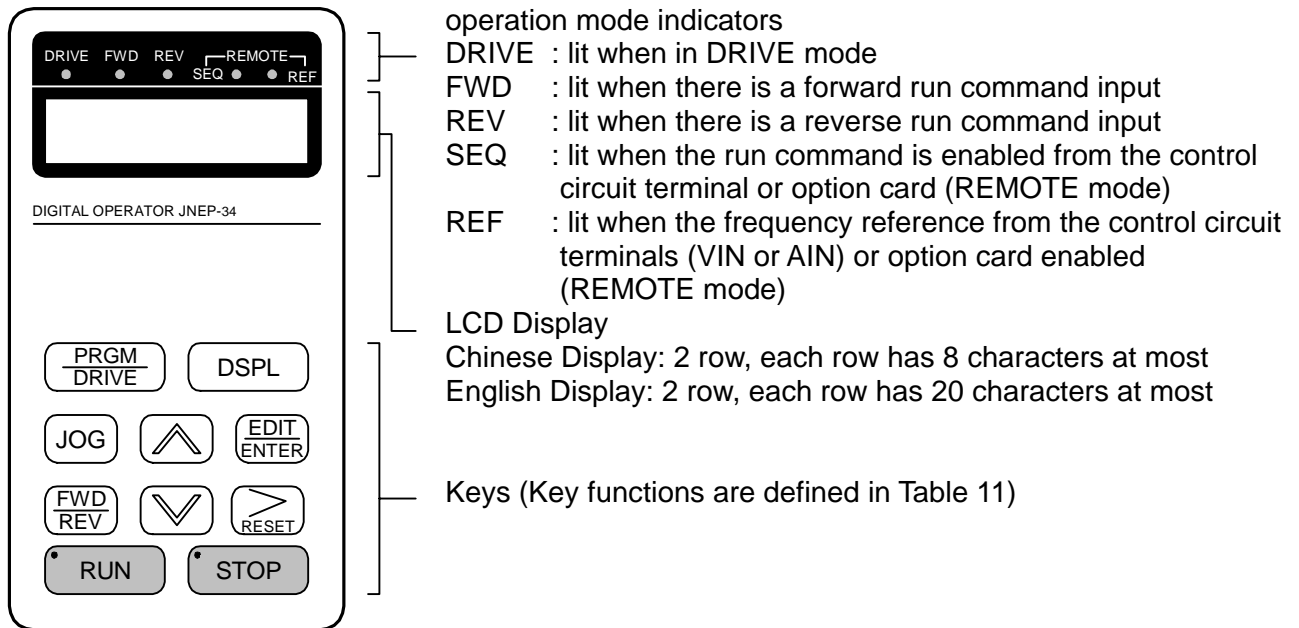

Fig 9 LCD Digital operator component names and functions

b> The LED digital operator component names and functions shown as below:

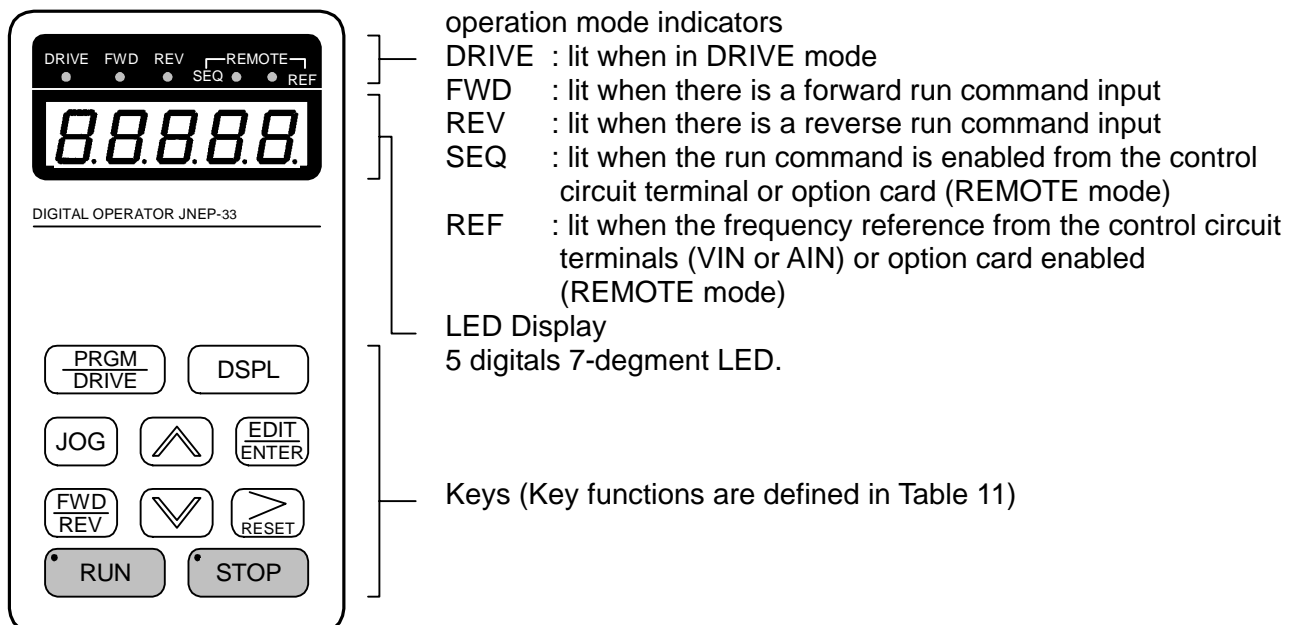









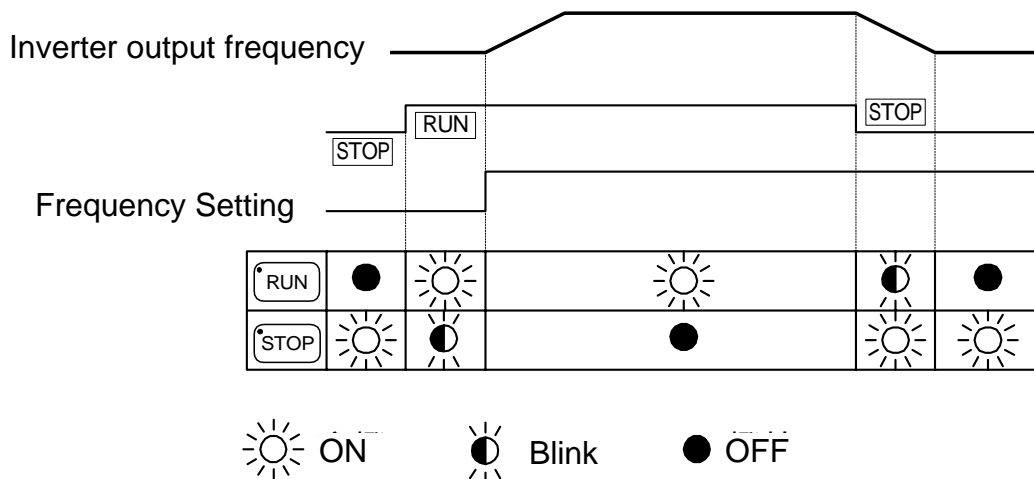

Fig 10 LED Digital operator component names and functions

Table 11 Key's functions

Key	Name	Function
	PRGM/DRIVE key	Switches between operation (PRGM) and operation (DRIVE).
	DSPL key	Display operation status
	JOG key	Enable jog operation from digital operator in operation (DRIVE).
	FWD/REV key	Select the rotation direction from digital operator.
	RESET key	Set the number of digital for user constant settings. Also it acts as the reset key when a fault has occurred.
	INCREMENT key	Select the menu items, groups, functions, and user constant name, and increment set values.
	DECREMENT key	Select the menu items, groups, functions, and user constant name, and decrement set values.
	EDIT/ENTER key	Select the menu items, groups, functions, and user constants name, and set values (EDIT). After finishing the above action, press the key (ENTER).
	RUN key	Start inverter operation in (DRIVE) mode when operator is used. The led will light.
	STOP key	Stop 7200GS operation from LCD digital operator. The key can be enable or disabled by setting a constant Sn-05 when operating from the control circuit terminal (in this case, the LED will light).



RUN, STOP indicator lights or blinks to indicate the 3 operating status:

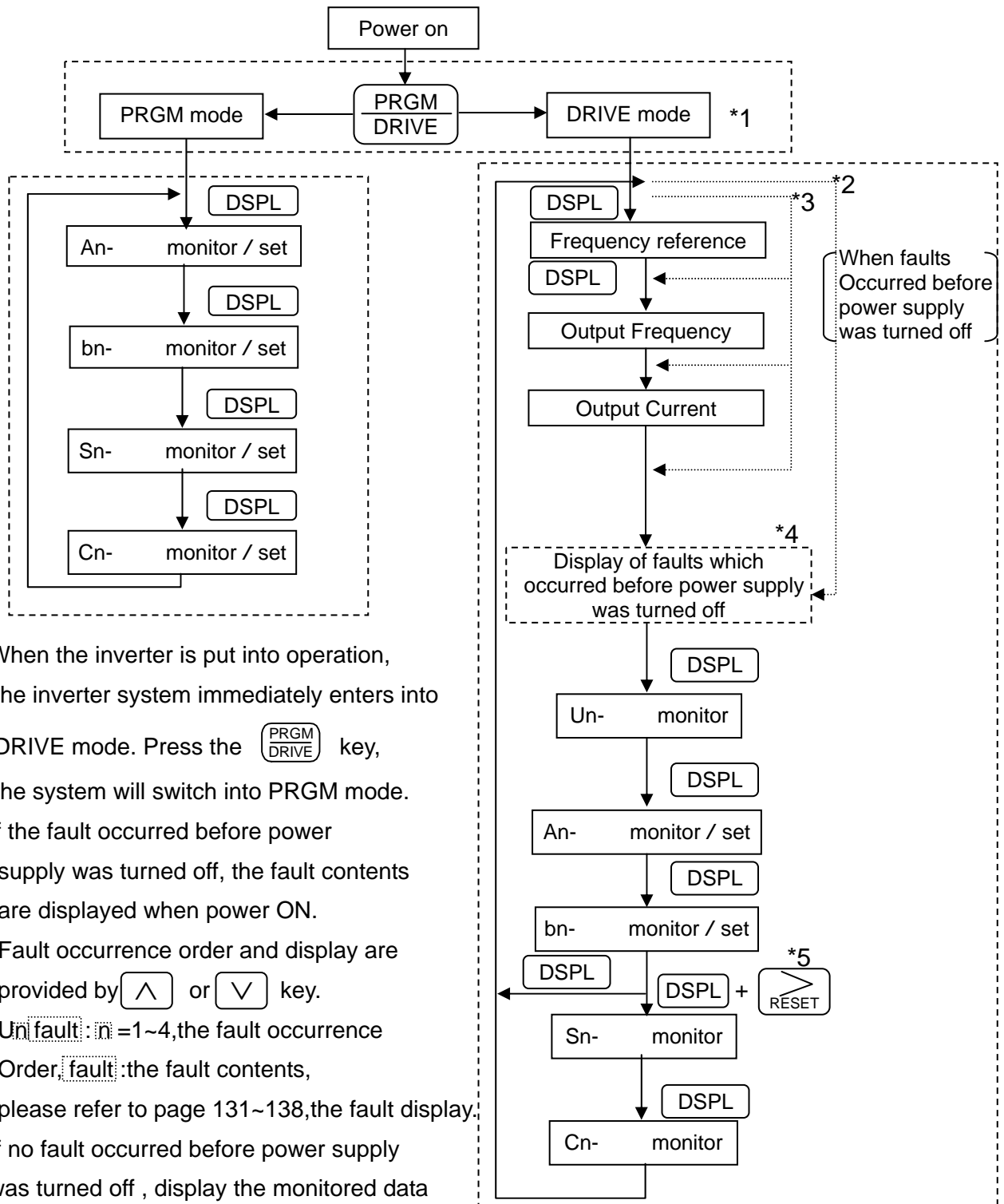

1.2 DRIVE mode and PRGM mode displayed contents



*1 : When the inverter is put into operation, the inverter system immediately enters into DRIVE mode. Press the  key, the system will switch into PRGM mode.

*2 : If the fault occurred before power supply was turned off, the fault contents are displayed when power ON. Fault occurrence order and display are provided by  or  key. Un fault: n =1~4, the fault occurrence Order, fault: the fault contents, please refer to page 131~138, the fault display.

*3 : If no fault occurred before power supply was turned off, display the monitored data according to the bn-10 setting

*4 : This block will be by passed if no fault occurred before power supply was turned off or a fault occurs and was reset by 

*5 : When in the DRIVE mode, press the  key and  key, the setting values of Sn- and Cn- will only be displayed for monitoring but not for changing or setting.

1.3 Parameter Description



The 7200GS has 4 groups of user parameters:

Parameters ^{*4}	Description
An-	Frequency command
bn-	Parameter settings can be changed during running
Sn-	System parameter settings (can be changes only after stop)
Cn-	Control parameter settings (can be changed only after stop)

The parameter setting of Sn-03 (operation status) will determine if the setting value of different parameter groups are allowed to be changed or only to be monitored, as shown below:

Sn-03	DRIVE mode		PRGM mode	
	To be set	To be monitored ^{*2}	To be set	To be monitored
0000 ^{*1}	An, bn	Sn, Cn	An, bn, Sn, Cn	-
0101 ^{*3}	An	bn, Sn, Cn	An	bn, Sn, Cn

*1 : Factory setting

*2 : When in DRIVE mode, the parameter group Sn-, Cn- can only be monitored if the  key and the  key are to be pressed at the same time,

*3 : After a few trial operation and adjustment, the setting value Sn-03 is set to be "0101" so as not be modified again.

*4 : The 7200GS has one group of monitoring parameters in addition to the above 4 groups of user parameters.

Un- : Can be monitored by the users under the DRIVE mode.

1.4 Sample example of using LCD digital operator

Note :

Before operation: Control parameter Cn-01 value must be set as the input AC voltage value. For example, Cn-01=380 if AC input voltage is 380.





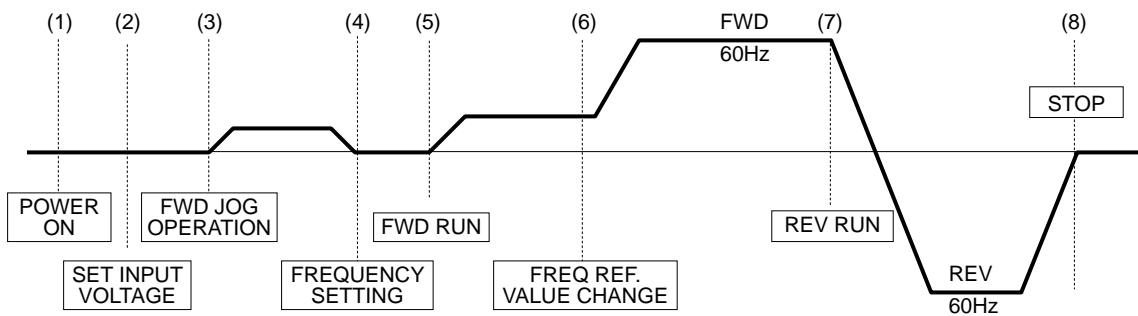





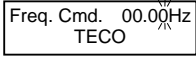

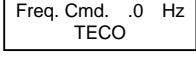



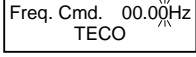



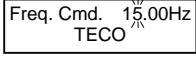

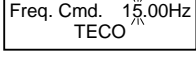

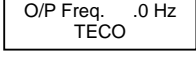

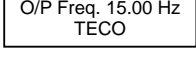

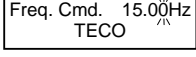

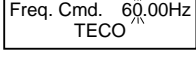

This sample example will explain the operating of 7200GAS according to the following time chart.

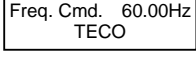
OPERATION MODE

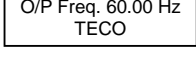

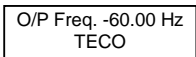
Sample operation

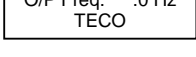
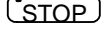
Description	Key Sequence	Digital Operator Display	Remarks
<p>(1) When POWER ON</p> <ul style="list-style-type: none"> ● Sect frequency reference value displayed ● Select PRGM mode <p>(2) Input voltage setting (e.g. AC input voltage is 380V)</p> <ul style="list-style-type: none"> ● Select CONTROL PARAMETER ● Display Cn-01 setting ● Input Voltage 380V <p>(continued)</p>	<p>PRGM-DRIVE</p> <p>DSPL Press 3 times</p> <p>EDIT-ENTER</p> <p>RESET ↑ ↓</p> <p>EDIT-ENTER</p>	<p>Freq. Cmd. 00.00Hz TECO</p> <p>An-01 Freq. Cmd. 1</p> <p>Cn-01- Input Voltage</p> <p>Cn-01=440.0V Input Voltage</p> <p>Cn-01=380.0V Input Voltage</p> <p>Entry Accepted</p>	<p>LED DRIVE OFF</p> <p>Display for 0.5 sec</p>

Description	Key Sequence	Digital Operator Display	Remarks
(continued)			
(3) FWD JOG			LED ON 
<ul style="list-style-type: none"> ● Select DRIVE mode ● Select output frequency displayed 			LED ON 
<ul style="list-style-type: none"> ● Select direction of rotation (When power on, initially defaulted FWD) ● Jog operation 			
(4) Frequency setting	 Press 5 times		
<ul style="list-style-type: none"> ● Select frequency cmd displayed ● Change frequency cmd 	  		
<ul style="list-style-type: none"> ● Set new frequency cmd 			
<ul style="list-style-type: none"> ● Select O/P frequency displayed 			Display for 0.5 sec Confirm the display.
(5) FWD run			LED ON 
(6) Frequency command change	 Press 5 times		
<ul style="list-style-type: none"> ● Select frequency cmd displayed ● Change reference value 	  		
<ul style="list-style-type: none"> ● Enter new frequency cmd setting 			
<ul style="list-style-type: none"> ● Select frequency cmd displayed 			Display for 0.5 sec Confirm the display.
(7) REV RUN			LED ON 
(8) STOP			LED ON 
			(Blinking while decel.) 

1.5 Control Mode Selection

The 7200GS standard with four selectable control modes:

- 1 GP: V/F control mode (General Purpose V/F control mode).
- 2 SL: Sensorless Vector Control mode (with motor parameters auto tuning function).
- 3 PID: PID with Auto Energy Saving Control mode.
- 4 PG: V/F+PG closed loop Control mode.

The control mode can be selected by parameter Sn-13:

Sn-13 setting	LCD Display (English)	Descriptions
00	Sn-13=00 V/F Ctrl Mode	GP: V/F control mode (factory setting)
01	Sn-13=01 SL Ctrl Mode	SL: Sensorless Vector Control mode
10	Sn-13=10 PID Ctrl Mode	PID: PID with Auto Energy Saving Control mode
11	Sn-13=11 PG Ctrl Mode	PG: V/F+PG closed loop Control mode

Caution:

1. Factory setting as V/F control mode (GP mode), When the required control mode is selected by Sn-13, the selected control mode is effective only after turning off the power supply till the display of digital operator (LCD or LED digital operator) is off, then turn on the power supply again.
2. The AUTO TUNE feature can be used to identify and store the important motor parameters in the first time sensorless vector operation after installation, and when switching to anyone of the other three control modes, then switched back to the sensorless vector control mode, the AUTO TUNE feature has to be used to identify and store the motor parameters once again.

2. SETTING USER CONSTANT

2.1 Descriptions of constant/function list

Formate

Parameter No.	Name	LCD Display (English)	Change During Operation	Setting Range	Setting Unit	Factory Setting	Valid Access Levels				Ref. Page
							GP	SL	PID	PG	
			or								

Descriptions

- Parameter NO.: NO. of the parameter group An- , bn- , Sn- , Cn- and Un- .
- Name: Parameter function name.
- LCD Display (English): The LCD display contents.
- Change During Operation:
 - : The parameter setting can be changed during running.
 - : The parameter setting can not be changed during running.
- Setting Range: The allowable setting range of the parameter.
- Setting Unit: The allowable setting unit (“ - ” means without unit).
- Factory Setting: Some of the parameter have different factory setting value under different control mode.
- Valid Access Levels:
 - 1 GP: V/F control mode (General Purpose V/F control mode).
 - 2 SL: Sensorless Vector Control mode (with auto tuning function).
 - 3 PID: PID with Auto Energy Saving Control mode.
 - 4 PG: V/F+PG closed loop Control mode.



: The parameter is access valid under this control mode (i.e. the parameter group can be monitored or set by the user)

: The parameter is access invalid under this control mode.

Number (1~3): different number with different function definitions.

2.2 Frequency command (in Multi-speed operation) An-

Under the DRIVE mode, the user can monitor the parameters and set their values.

Parameter No.	Name	LCD Display (English)	Change During Operation	Setting Range	Setting Unit	Factory Setting	Valid Access Levels				Ref. Page
							GP	SL	PID	PG	
An-01	Frequency Command 1	An-01=000.00Hz Frequency Command 1		0.00~180.00 Hz	0.01Hz	00.00Hz					
An-02	Frequency Command 2	An-02=000.00Hz Frequency Command 2		0.00~180.00 Hz	0.01Hz	0.00Hz					
An-03	Frequency Command 3	An-03=000.00Hz Frequency Command 3		0.00~180.00 Hz	0.01Hz	0.00Hz					
An-04	Frequency Command 4	An-04=000.00Hz Frequency Command 4		0.00~180.00 Hz	0.01Hz	0.00Hz					
An-05	Frequency Command 5	An-05=000.00Hz Frequency Command 5		0.00~180.00 Hz	0.01Hz	0.00Hz					
An-06	Frequency Command 6	An-06=000.00Hz Frequency Command 6		0.00~180.00 Hz	0.01Hz	0.00Hz					
An-07	Frequency Command 7	An-07=000.00Hz Frequency Command 7		0.00~180.00 Hz	0.01Hz	0.00Hz					
An-08	Frequency Command 8	An-08=000.00Hz Frequency Command 8		0.00~180.00 Hz	0.01Hz	0.00Hz					
An-09	Jog Frequency Command	An-09=006.00Hz Jog Command		0.00~180.00 Hz	0.01Hz	6.00Hz					

*1. The displayed "Setting Unit" can be changed through the parameter Cn-20.

*2. At factory setting, the value of "Setting Unit" is 0.01Hz.

*3. The setting of An-01~09 should be with the multi-function analog terminals 5 ~ 8 .

2.3 Parameters Can Be Changed during Running bn-

Under the DRIVE mode, the Parameter group can be monitored and set by the users.

Function	Parameter No.	Name	LCD Display (English)	Change During Operation	Setting Range	Setting Unit	Factory Setting	Valid Access Levels				Ref. Page
								GP	SL	PID	PG	
Acc/Dec time	bn-01	Acceleration Time 1	bn-01=0010.0s Acc. Time 1		0.0~6000.0s	0.1s	10.0s					2-4
	bn-02	Deceleration Time 1	bn-02=0010.0s Dec. Time 1		0.0~6000.0s	0.1s	10.0s					
	bn-03	Acceleration Time 2	bn-03=0010.0s Acc. Time 2		0.0~6000.0s	0.1s	10.0s					
	bn-04	Deceleration Time 2	bn-04=0010.0s Dec. Time 2		0.0~6000.0s	0.1s	10.0s					
Analog Frequency Command	bn-05	Analog Frequency Cmd. Gain (Voltage)	bn-05=0100.0% ~Freq. Cmd. Gain		0.0~1000.0%	0.1%	100.0%					2-5
	bn-06	Analog Frequency Cmd. Bias (Voltage)	bn-06=0000.0% ~Freq. Cmd. Bias		-100.0%~100.0%	0.1%	0.0%					
Torque Boost	bn-07	Auto Torque Boost Gain (Ineffective in Auto energy-saving mode)	bn-07=1.0 Auto_Boost Gain		0.0~2.0	0.1	1.0* ¹					2-5
Motor Slip	bn-08	Rated Slip of Motor	bn-08 =0.0% Motor Rated Slip		0.0~9.9%* ²	0.1%	0.0%	1	2			2-6 2-7
Energy Saving	bn-09	Energy Saving Gain	bn-09=080% Eg. Saving Gain		0~200%	1%	80%					2-7
	bn-10	Monitor No. After power ON	bn-10=1 Power On. Contents		1~3	1	1					2-7
A01 Gain	bn-11	Multi-Function Analog Output A01 Gain * ³	bn-11=1.00 ~Output A01 Gain		0.01~2.55	0.01	1.00	1	1	1	2	2-7~2-9
A02 Gain	bn-12	Multi-Function Analog Output A02 Gain * ³	bn-12=1.00 ~Output A02 Gain		0.01~2.55	0.01	1.00	1	1	1	2	
PID Control	bn-13	PID Detection Gain	bn-13=01.00 PID Det. Gain		0.01~10.00	0.01	1.00					2-9 4-9
	bn-14	PID Proportional Gain	bn-14=01.0 PID P-Gain		0.0~10.0	0.1	1.0					
	bn-15	PID Integral Gain	bn-15=010.0s PID I-Time		0.0~100.0s	0.1s	10.0s					
	bn-16	PID Differential Time	bn-16=0.00s PID D-Time		0.00~1.00s	0.01s	0.00s					
	bn-17	PID Bias	bn-17=000% PID Bias		0~109%* ²	1%	0%					

*1. The factory setting value is 1.2 for SL control mode.

*2. Cn-04 is to be the 100% level.

*3. When AO-12 option card used, bn-11 & bn-12 corresponding to gain of analog signal AO1 & AO2 of AO-12.

(1) Acceleration Time 1 (bn-01)

(2) Deceleration Time 1 (bn-02)

(3) Acceleration Time 2 (bn-03)

(4) Deceleration Time 2 (bn-04)

Parameter No.	Name	LCD Display (English)	Change During Operation	Setting Range	Setting Unit	Factory Setting	Valid Access Levels			
							GP	SL	PID	PG
bn-01	Acceleration Time 1	bn-01=0010.0s Acc. Time 1		0.0~6000.0s	0.1s	10.0s				
bn-02	Deceleration Time 1	bn-02=0010.0s Dec. Time 1		0.0~6000.0s	0.1s	10.0s				
bn-03	Acceleration Time 2	bn-03=0010.0s Acc. Time 2		0.0~6000.0s	0.1s	10.0s				
bn-04	Deceleration Time 2	bn-04=0010.0s Dec. Time 2		0.0~6000.0s	0.1s	10.0s				

- Set individual Acceleration / Deceleration times
- Acceleration time: the time required to go from 0% to 100% of the maximum output frequency.
- Deceleration time: the time required to go from 0% to 100% of the maximum output frequency.
- If the acceleration / deceleration time sectors 1 and 2 are input via the multifunction inputs terminal 5 ~ 8, the acceleration / deceleration can be switched between 2 sectors even in the running status.

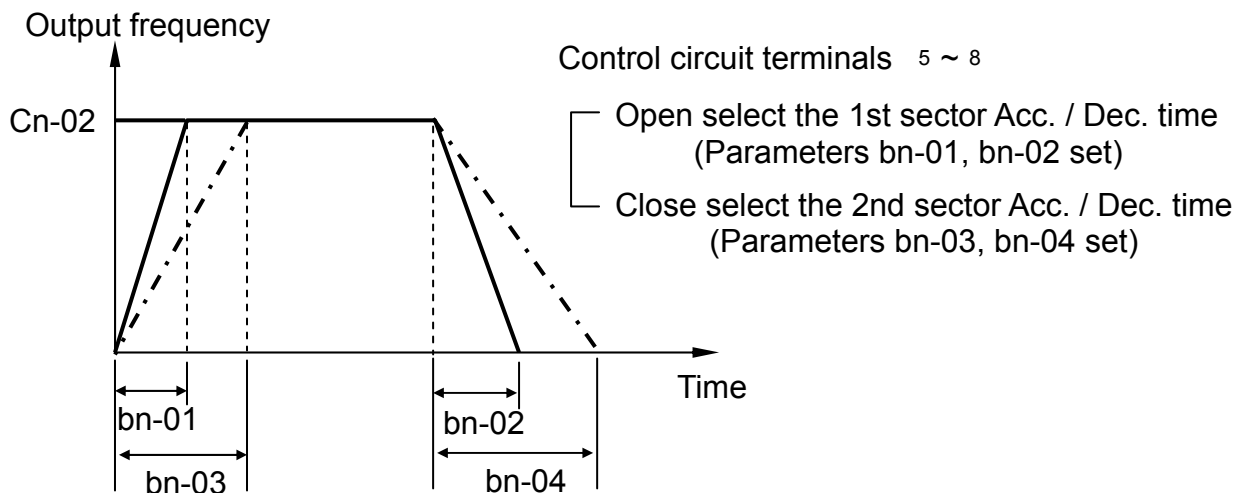

Note:

1. To set the S-curve characteristics function, please refer to Sn-06.

(5) Analog Frequency Cmd. Gain (Voltage) (bn-05)

(6) Analog Frequency Cmd. Bias (Voltage) (bn-06)

Parameter No.	Name	LCD Display (English)	Change During Operation	Setting Range	Setting Unit	Factory Setting	Valid Access Levels			
							GP	SL	PID	PG
bn-05	Analog Frequency Cmd. Gain (Voltage)	bn-05=0100.0% ~Freq. Cmd. Gain		0.0~1000.0%	0.1%	100.0%				
bn-06	Analog Frequency Cmd. Bias (Voltage)	bn-06=0000.0% ~Freq. Cmd. Bias		-100.0%~100.0%	0.1%	0.0%				

●bn-05: The input level when frequency reference voltage is 10V is set in units of 1%, examples are shown below.

●bn-06: The input level when frequency reference voltage is 0V is set in units of 1%

<Example>

- 1 bn-05 = 50.0
- 2 a: bn-06 = 10.0
- b: bn-06 = -10.0

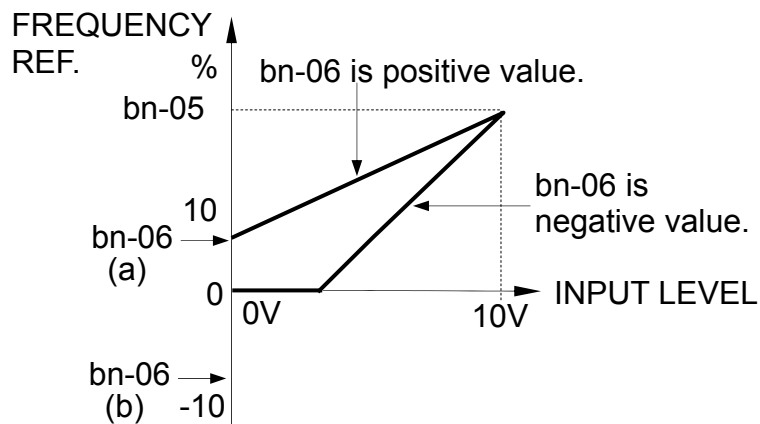

(7) Auto Torque Boost Gain (bn-07)

Parameter No.	Name	LCD Display (English)	Change During Operation	Setting Range	Setting Unit	Factory Setting	Valid Access Levels			
							GP	SL	PID	PG
bn-07	Auto Torque Boost Gain (Ineffective in Auto energy-saving mode)	bn-07=1.0 Auto_Boost Gain		0.0~2.0	0.1	1.0				

● The inverter can increase the output torque to compensate the load increase automatically through the auto torque boost function. Then the output voltage will increase. As a result, the fault trip cases can be decreased. The energy efficiency is also improved. In the case that the wiring distance between the inverter and the motor is too long (e.g. more than 100m), the motor torque is a little short because of voltage drop. Increase the value of bn-11 gradually and make sure the current will not increase too much. Normally, no adjustment is required.

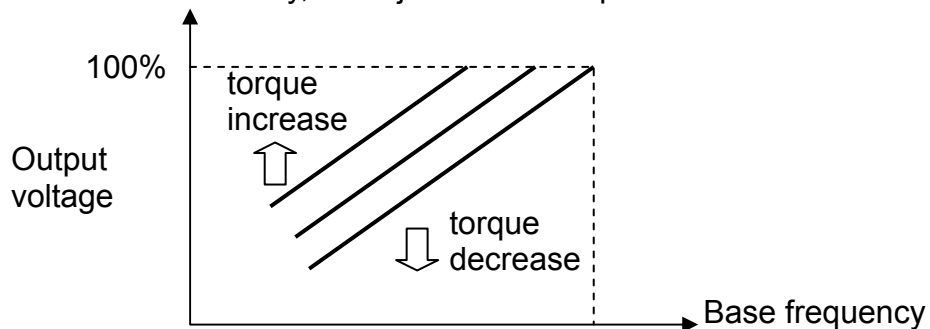

bn-07 is ineffective when the Auto-Energy Saving function is effective (Sn-08=X1XX) in the PID control mode (Sn-13=10).

(8) Rated Slip of Motor (bn-08)

1. GP

Parameter No.	Name	LCD Display (English)	Change During Operation	Setting Range	Setting Unit	Factory Setting	Valid Access Levels			
							GP	SL	PID	PG
bn-08	Rated Slip of Motor	bn-08 = 0.0% Motor Rated Slip		0.0~9.9%	0.1%	0.0%	1	2		

- Motor rated slip is set in units of 0.1%

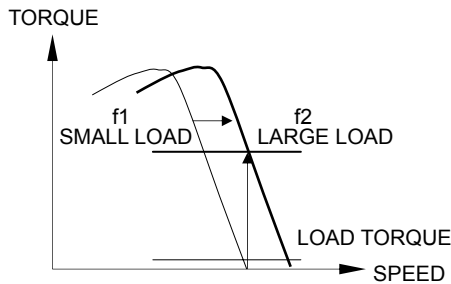

Simplified speed control is performed without encoder (PG or TG).
With frequency offset f_1 to f_2 , speed fluctuation due to load is reduced.

- When the output current of the inverter is larger than motor no-load current (Cn-34), the output frequency of the inverter is compensated.
- The amount of frequency compensation is determined by the formula below. The maximum voltage frequency (Cn-04) is 100%.
- If the output current is equal to the motor rated current (Cn-09), the output frequency is compensated for by the motor rated slip (bn-08).
- If frequency reference is equal to or smaller than minimum output frequency (Cn-07) or motor is in a regeneration mode, slip compensation is not performed.
- The amount of output frequency compensation in a constant torque area and a constant output area is shown in the figure below.

Amount of output frequency compensation =

$$\frac{\text{motor rated slip}}{\left(\frac{\text{motor rated current} - \text{motor no-load current}}{\text{motor rated current}} \right)} \times \left(\frac{\text{output current} - \text{motor no-load current}}{\text{motor rated current}} \right)$$

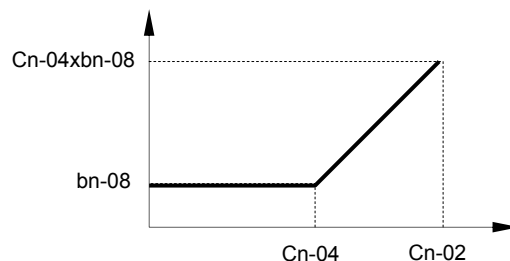

Motor rated current: Cn-09
Motor no-load current: Cn-34
Motor rated slip: bn-08

- When 0.0 is set in bn-08, output frequency compensation is not performed.

2. SL

Parameter No.	Name	LCD Display (English)	Change During Operation	Setting Range	Setting Unit	Factory Setting	Valid Access Levels			
							GP	SL	PID	PG
bn-08	Rated Slip of Motor	bn-08 =1.7Hz Motor Rated Slip		0.0~20.0Hz	0.1Hz	1.7Hz*	1	2		

* Factory setting depending on inverter capacity (Sn-01 set value)

- To calculate the motor rated slop by the below equation:

Motor Rated Slop (Hz)= [rated speed (rpm) - nameplate full load speed (rpm)]

$$\times \frac{P}{120} \text{ (Hz)}$$

P=motor poles

(9) Energy Saving Gain (bn-09)

Parameter No.	Name	LCD Display (English)	Change During Operation	Setting Range	Setting Unit	Factory Setting	Valid Access Levels			
							GP	SL	PID	PG
bn-09	Energy Saving Gain	bn-09=080% Eg. Saving Gain		0~200%	1%	80%				

- Input the energy-saving operation command (Sn-15~18=63), While a light load causes the inverter output voltage to be reduced and save energy. Set this value as a percentage of the V/F pattern. The setting range is 0~200%. The energy saving function is disabled when energy saving gain (bn-09) is 100%.
- Please refer to page 2-56, the time chart when energy-saving operation command is input.

(10) Monitor No. after Power ON (bn-10)

Parameter No.	Name	LCD Display (English)	Change During Operation	Setting Range	Setting Unit	Factory Setting	Valid Access Levels			
							GP	SL	PID	PG
bn-10	Monitor No. After power ON	bn-10=1 Power On. Contents		1~3	1	1				

- Data to be monitored after turning on power supply is selected with constant NO.
 - bn-10=1 : Frequency reference
 - bn-10=2 : Output frequency
 - bn-10=3 : Output current

(11) Multi-function Analog Output A01 Gain (bn-11)

(12) Multi-function Analog Output A02 Gain (bn-12)

1. GP, SL, PID

Parameter No.	Name	LCD Display (English)	Change During Operation	Setting Range	Setting Unit	Factory Setting	Valid Access Levels			
							GP	SL	PID	PG
bn-11	Multi-Function Analog Output A01 Gain	bn-11=1.00 ~Output A01 Gain		0.01~2.55	0.01	1.00	1	1	1	2
bn-12	Multi-Function Analog Output A02 Gain	bn-12=1.00 ~Output A02 Gain		0.01~2.55	0.01	1.00	1	1	1	2

- To set the output voltage level of A01 channel of analog monitor optional card (AO-12) by bn-11 and bn-12. The output voltage level is set in the form of $10V \times bn-11$ (or bn-12).

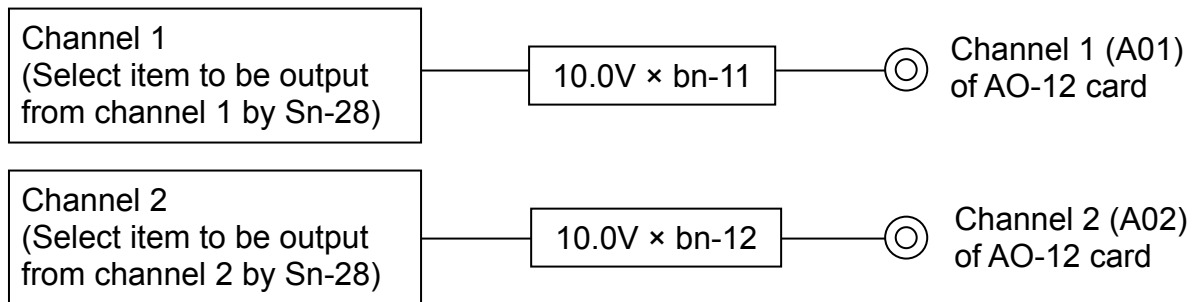

- To set the output voltage level of multi-function analog output terminal 21. The output voltage level is set in the form of $10V \times bn-11$

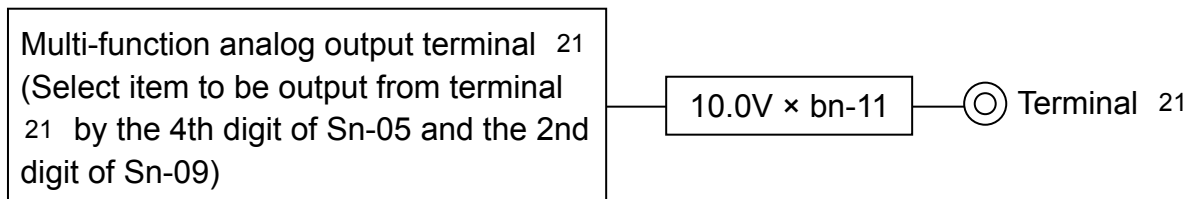

2. PG

Parameter No.	Name	LCD Display (English)	Change During Operation	Setting Range	Setting Unit	Factory Setting	Valid Access Levels			
							GP	SL	PID	PG
bn-11	Multi-Function Analog Output 21 items	bn-11=2 Output Frequency		1~13	-	2	1	1	1	2
bn-12	Multi-Function Analog Output 21 Gain	bn-12= Output Gain		0.01~2.55	0.01	0.5	1	1	1	2

- bn-11: Select the item to be output from terminal 21

bn-11 setting	LCD Display (English)	Functions
01	Freq. Cmd.	Frequency Command (Reference)
02	O/P Freq.	Output Frequency
03	O/P I	Output Current
04	O/P V	Output Voltage
05	DC Volt	DC Voltage
06	O/P KW	Output Power (KW)
07-11	Reserved	Not used
12	Sp. FBK	Amount of speed feedback
13	Sp. Compen.	Amount of speed control compensation

-
- bn-12: To set the output voltage level of multi-function analog output terminal 21 .
The output voltage level is set in the form of $10V \times bn-12$

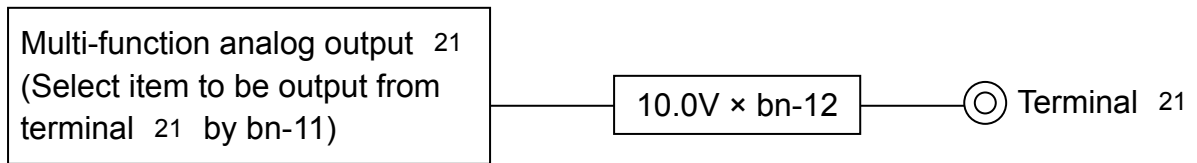

The analog monitor optional card (AO-12) can not be used in PG control mode.

(13) PID Control function (bn-13~bn-17)

- Please refer to Appendix C "PID CONTROL".

2.4 System Parameters Sn -

Function	Parameter No.	Name	LCD Display (English)	Description	Factory Setting	Change During Operation	Valid Access Levels				Ref. Page	
							GP	SL	PID	PG		
Capacity Setting	Sn-01	Inverter Capacity Selection	Sn-01=29 440V 25HP	Inverter Capacity Selection	*1		1	2	1	1	2-14~ 2-21	
V/F Curve	Sn-02	V/F Curve Selection	Sn-02=01 V/F Curve	V/F pattern Selection	01						2-22~ 2-24	
Operator Status	Sn-03	Display of Operator	Sn-03=0000 Operate Setting	0000: Setting and reading of An- , Bn- , Cn- , Sn- enabled 0101: Setting and reading of An- , Reading of Bn- , Cn- , Sn- enabled	0000						2-25	
		Constants Initialization		1110: Constants Initialigation (2-wire)* ² 1111: Constants Initialigation (3-wire)* ²								
Operation Mode Select 1	Sn-04	Operation Mode Select	Sn-04=0011 Stopping Method	--0: Frequency Command = Control circuit terminals 13 or 14 --1: Frequency Command = Frequency Command 1 (An-01) -0 -: RUN . STOP Command = Control circuit terminals -1 -: RUN . STOP Command = LCD Digital Operator	0011						2-26~ 2-28	
		Stopping Method Selection		00- -: Stopping method = Ramp to stop 01- -: Stopping method =Coasting to stop 10- -: Stopping method =Full-range DC injection braking stop 11- -: Stopping method = Coasting stop (timer function provided)								
Operation Mode Select 2	Sn-05	I/O terminal function selection	Sn-05=0000 I/O term. Fct	--0: Stop key effective during operation from control terminal --1: Stop key effective during operation from control terminal	0000							2-29~ 2-30
				-0 -: Reverse run enabled -1 -: Reverse run disabled								
				-0 -: Control input terminals 1 ~ 8 are scanned twice. -1 -: Control input terminals 1 ~ 8 are scanned once.								
				0- -: Selection of item to be analog output (terminals 21 , 22)* ³ 1- -: Selection of item to be analog output (terminals 21 , 22)* ³								
Operation Mode Select 3	Sn-06	S-curve and frequency Command characteristics	Sn-06=0000 S-curve Cmd. Char.	--00: S curve=0.2sec --01: S curve=0.0sec (NO S curve) --10: S curve=0.5sec --11: S curve=1.0sec	0000							2-31~ 2-33
				-0 -: Reference command has forward characteristics (0-10V or 4-20mA/0~100%) -1 -: Reference command has reverse characteristics (0-10V or 4-20mA/100~0%)								
				0- -: Stop by reference input when frequency reference is missing 1- -: Operation to continue with 80% of frequency reference when frequency reference is missing								

Function	Parameter No.	Name	LCD Display (English)	Description	Factory Setting	Change During Operation	Valid Access Levels				Ref. Page
							GP	SL	PID	PG	
Operation Mode Select 4	Sn-07	Overtorque Detection	Sn-07=0000 Over Tq. Detect	--0: Overtorque detection disabled --1: Overtorque detection enabled	0000		1	2	1	1	2-34~ 2-35
				-0 -: Enabled only if at agreed frequency -1 -: Enable during operation (except during DC injection)							
				-0 -: Operation continued after overtorque is detected -1 -: Coasts to stop if overtorque is detected							
				0- -: Overtorque detection with current 1- -: Overtorque detection with torque							
Operation Mode Select 5	Sn-08	Option Card/Inverter Function Selection	Sn-08=0100 AI/DI & SI-M Card	--0: Frequency reference input by option card (AI-14B, DI-08 or SI-M) --1: Frequency reference input by digital operator or control circuit input terminals	0100		1	1	2	3	2-36~ 2-37
				-0 -: RUN/STOP command input by option card (AI-14B, DI-08 or SI-M) -1 -: RUN/STOP command input by digital operator or control circuit input terminals							
				00- -: SI-M communication fault, deceleration to stop (bn-02) 01- -: SI-M communication fault, coast to stop 10- -: SI-M communication fault, deceleration to stop (bn-04) 11- -: SI-M communication fault, continue to run							
Operation Mode Select 6	Sn-09	Analog Output Selection and Slip Compensation	Sn-09=0000 ~Output Select	--0: Analog output (terminal 21 ~ 22) depends on Sn-05 4th digit and Sn-09 2nd digit. --1: Analog output (terminal 21 ~ 22) is set by SI-M card.	0000		1	2	3		2-38~ 2-39
				-0 -: Analog output (terminal 21 ~ 22) -1 -: Analog output (terminal 21 ~ 22)							
				-0 -: Not used -1 -: Not used							
				0- -: No slip compensation during regenerating 1- -: Slip compensation even during regenerating							
Protective Characteristic Select 1	Sn-10	Stall Prevention	Sn-10=0000 Stall Select	--0: Stall prevention during acceleration enabled --1: Stall prevention during acceleration disabled	0000						2-40~ 2-41
				-0 -: Stall prevention during deceleration enabled -1 -: Stall prevention during deceleration disabled							
				-0 -: Stall prevention during running enabled -1 -: Stall prevention during running disabled							
				0- -: Decel time during stall prevention (bn-02 set value) 1- -: Decel time during stall prevention (bn-04 set value)							

Function	Parameter No.	Name	LCD Display (English)	Description	Factory Setting	Change During Operation	Valid Access Levels				Ref. Page
							GP	SL	PID	PG	
Protective Characteristic Select 2	Sn-11	Retry and momentary power loss protection	Sn-11=0000 Retry & Ride -Thru	--0: Not used --1: Not used	0000						2-42
				-0 -: Fault contact is not energized during Retry operation -1 -: Fault contact is energized during Retry operation							
				-0 -: Operation stopped by momentary power loss detection (UV1) -1 -: Operation continues after momentary power loss							
				0 -: Not used 1 -: Not used							
Protective Characteristic Select 3	Sn-12	External Fault Function Selection	Sn-12=0100 External Fault	--0: External fault input (terminal 3) is NO-contact input --1: External fault input: is NC-contact input	0100						2-43
				-0 -: External fault signal: always detected -1 -: External fault signal: detected during running only							
				00 -: External fault detected: ramp to stop (major fault) by bn-02 set value 01 -: External fault detected: Coasting to stop (major fault)							
				10 -: External fault detected: ramp to stop (major fault) by bn-04 set value 11 -: External fault detected: operation to continue (major fault)							
Control Mode Select	Sn-13	Control Mode Select	Sn-13=00 V/F Ctrl mode	--00: GP - V/F Control mode --01: SL - Sensorless Vector Control mode --10: PID - PID With Auyo Energy Saving Control mode --11: PG - V/F+PG closed loop Control mode	00						2-44
Protective Characteristic Select 4	Sn-14	Electronic Thermal Overload Protection	Sn-14=0000 Over Load Select	--0: Motor overload (OL1) protection: effective --1: Motor overload (OL1) protection: ineffective	0000						2-45
				-0 -: Motor overload protection: standard motor -1 -: Motor overload protection: Inverter duty motor							
				-0 -: Motor overload protection time constants are standard time (8 minutes) -1 -: Motor overload protection time constants are short-time (5 minutes)							
				0 -: Inverter overload (OL2) protection 103% continuous, 150% for one minute* ² 1 -: Inverter overload (OL2) protection 113% continuous, 123% for one minute* ²							

Function	Parameter No.	Name	LCD Display (English)	Description	Factory Setting	Change During Operation	Valid Access Levels				Ref. Page
							GP	SL	PID	PG	
Multi-Function Select	Sn-15	Terminal 5 Function	Sn-15=03 Term.5 Function	00 ~ 66 Selects terminal 5 function (factory preset for multi-step speed reference 1)	03						2-46
	Sn-16	Terminal 6 Function	Sn-16=04 Term.6 Function	00 ~ 66 Selects terminal 6 function (factory preset for multi-step speed reference 2)	04						2-46
	Sn-17	Terminal 7 Function	Sn-17=06 Term.7 Function	00 ~ 66 Selects terminal 7 function (factory preset for jog frequency reference)	06						2-46
	Sn-18	Terminal 8 Function	Sn-18=08 Term.8 Function	00 ~ 66 Selects terminal 8 function (factory preset for external baseblock by NO contact input)	08						2-46
	Sn-19	Multi-function analog input (Terminal 16)	Sn-19=00 Multi-Fct/V Input	00 ~ 0B Selects terminal 16 function (factory preset for auxiliary frequency command)	00						2-57
	Sn-20	Multi-function contact output (Terminal 9 - 10)	Sn-20=00 Term. 9 Function	00 ~ 0E Selects terminal 9 - 10 function (factory preset for running)	00						2-59
	Sn-21	Multi-function PHC output (Terminal 25 - 27)	Sn-21=01 Term. 25 Function	00 ~ 0E Selects terminal 25 - 27 function (factory preset for zero speed)	01						2-59
	Sn-22	Multi-function PHC output (Terminal 26 - 27)	Sn-22=02 Term. 26 Function	00 ~ 0E Selects terminal 26 - 27 function (factory preset for Agreed frequency)	02						2-59
Language	Sn-23	LCD Language selection	Sn-23=0 Language: English	0: English 1: Chinese	0						2-62
-	Sn-24	Not used	Sn-24=00 Reserved	-	-	-	-	-	-	-	-
Option Card Function Select	Sn-25 ~ Sn-28	*3	*3	*3	*3		1	2	3	4	2-63 4-16
Auto-tuning	Sn-29	Motor parameters Auto tuning Selection	Sn-29=0 Motor Auto Test	0: Autotuning invalid 1: Autotuning valid							2-67

*1. Differs according to inverter capacity.

*2. Effective only for inverter models of capacity 220V 40HP (30KW) or more, 440V 75HP (55KW) or more.

*3. Differs according to control mode.

Inverter Capacity Selection **Sn-01**

Inverter capacity has been preset at the factory. However, if a spare control board is used, reset the inverter capacity referring to the table below. Control constant Cn-factory setting values (initial values) differ according to Sn-01 setting.

1. GP, PID, PG

Parameter No.	Name	LCD Display (English)	Description	Factory Setting	Change During Operation	Valid Access Levels			
						GP	SL	PID	PG
Sn-01	Inverter Capacity Selection	Sn-01=29 440V 25HP	Inverter Capacity Selection	*1		1	2	1	1

Inverter Capacity Selection

220V Class

Name		Data of Sn-01		00	01	02	03	04	05	06	07
Inverter rating		HP		0.5	1	2	3	5	7.5	10	15
Inverter rated capacity		kVA		1.4	2.1	2.7	4.1	6.9	10.3	13.7	20.6
Max. applicable motor capacity		HP (kW)		0.5 (0.4)	1 (0.75)	2 (1.5)	3 (2.2)	5 (3.7)	7.5 (5.5)	10 (7.5)	15 (11)
Inverter rated current		A		3.2	4.8	6.4	9.6	16	24	32	48
Factory Setting	Cn-09	Motor rated current	A	1.9	3.4	6.1	8.7	13.5	20.1	25.1	36.7
	Cn-23	Carrier frequency upper limit	kHz	15.0	15.0	15.0	15.0	15.0	15.0	15.0	15.0
	Cn-24	Carrier frequency lower limit	kHz	15.0	15.0	15.0	15.0	15.0	15.0	15.0	15.0
	Cn-25	Carrier frequency proportional gain		0	0	0	0	0	0	0	0
	Cn-31	Motor phase-to-phase resistance	Ω	11.760	5.732	2.407	1.583	0.684	0.444	0.288	0.159
	Cn-32	Torque compensation iron loss	W	48	64	108	142	208	252	285	370
	Cn-33	Torque compensation limit	V	50	50	50	50	50	50	50	50
	Cn-37	Momentary power loss assurance time	s	0.7	1.0	1.0	1.0	2.0	2.0	2.0	2.0
	Cn-40	Minimum baseblock time	s	0.5	0.5	0.5	0.5	0.5	0.7	0.7	0.7
Cn-41*	V/F during speed search	%	100	100	100	100	100	100	100	100	

Inverter Capacity Selection

220V Class

Name		Data of Sn-01									
		08	09	0A	0B	0C	0D	0E	0F		
Inverter rating	HP	20	25	30	40	50	60	75	100		
Inverter rated capacity	kVA	27.4	34	41	54	68	78	95	130		
Max. applicable motor capacity	HP (kW)	20 (15)	25 (18.5)	30 (22)	40 (30)	50 (37)	60 (45)	75 (55)	100 (75)		
Inverter rated current	A	64	80	96	130	160	183	224	300		
Factory Setting	Cn-09	Motor rated current	A	50.3	62.9	72.9	96.7	124	143.5	183.5	230
	Cn-23	Carrier frequency upper limit	kHz	15.0	15.0	15.0	10.0	10.0	3.0*	3.0*	3.0*
	Cn-24	Carrier frequency lower limit	kHz	15.0	15.0	15.0	10.0	10.0	3.0*	3.0*	3.0*
	Cn-25	Carrier frequency proportional gain		0	0	0	0	0	0	0	0
	Cn-31	Motor phase-to-phase resistance	Ω	0.109	0.077	0.060	0.041	0.033	0.028	0.019	0.007
	Cn-32	Torque compensation iron loss	W	471	425	582	536	641	737	790	1800
	Cn-33	Torque compensation limit	V	50	50	50	50	50	50	50	50
	Cn-37	Momentary power loss assurance time	s	2.0	2.0	2.0	2.0	2.0	2.0	2.0	2.0
	Cn-40	Minimum baseblock time	s	0.7	1.0	1.0	1.0	1.0	1.0	1.0	1.0
	Cn-41*	V/F during speed search	%	100	100	100	80	80	80	80	80

* The allowable maximum carrier frequency is 10kHz

* In PG mode, the function of Cn-41 is disabled.

Inverter Capacity Selection

440V Class

Name		Data of Sn-01												
		20	21	22	23	24	25	26	27	28	29	2A		
Inverter rating	HP	0.5	1	2	3	5	7.5	10	15	20	25	30		
Inverter rated capacity	kVA	1.4	2.1	3.4	4.1	6.9	10.3	13.7	20.6	27.4	34	41		
Max. applicable motor capacity	HP (kW)	0.5 (0.4)	1 (0.75)	2 (1.5)	3 (2.2)	5 (3.7)	7.5 (5.5)	10 (7.5)	15 (11)	20 (15)	25 (18.5)	30 (22)		
Inverter rated current	A	1.6	2.6	4.0	4.8	8	12	16	24	32	40	48		
Factory Setting	Cn-09	Motor rated current	A	1.0	1.7	2.9	4.0	6.8	10.1	12.6	18.6	24.8	31.1	36.3
	Cn-23	Carrier frequency upper limit	kHz	15.0	15.0	15.0	15.0	15.0	15.0	15.0	15.0	10.0	10.0	
	Cn-24	Carrier frequency lower limit	kHz	15.0	15.0	15.0	15.0	15.0	15.0	15.0	15.0	10.0	10.0	
	Cn-25	Carrier frequency proportional gain		0	0	0	0	0	0	0	0	0	0	
	Cn-31	Motor phase-to-phase resistance	Ω	47.02	22.929	9.629	6.333	2.735	1.776	1.151	0.634	0.436	0.308	0.239
	Cn-32	Torque compensation iron loss	W	48	64	108	142	208	252	285	370	471	425	582
	Cn-33	Torque compensation limit	V	100	100	100	100	100	100	100	100	100	100	100
	Cn-37	Momentary power loss assurance time	s	1.0	1.0	1.0	1.0	2.0	2.0	2.0	2.0	2.0	2.0	2.0
	Cn-40	Minimum baseblock time	s	0.5	0.5	0.5	0.5	0.5	0.7	0.7	0.7	0.7	1.0	1.0
	Cn-41*	V/F during speed search	%	100	100	100	100	100	100	100	100	100	100	100

Inverter Capacity Selection

440V Class

Name		Data of Sn-01												
		2B	2C	2D	2E	2F	30	31	32	33	34	35	36	
Inverter HP rating		40	50	60	75	100	125	150	175	215	250	300	400	
Inverter rated capacity kVA		54	68	82	110	138	180	195	230	260	290	385	514	
Max. applicable motor capacity (kW) HP		40 (30)	50 (37)	60 (45)	75 (55)	100 (75)	125	150 (110)	175	215 (160)	250 (185)	300 (220)	400 (300)	
Inverter rated current A		64	80	96	128	165	192	224	270	300	340	450	600	
Factory Setting	Cn-09	Motor rated current A	48.7	59.0	70.5	80	114	145	175	205	235	290	348	465
	Cn-23	Carrier frequency upper limit kHz	10.0	10.0	10.0	10.0	3.0*	3.0*	3.0*	3.0*	3.0*	2.0	2.0	2.0
	Cn-24	Carrier frequency lower limit kHz	10.0	10.0	10.0	10.0	3.0*	3.0*	3.0*	3.0*	3.0*	2.0	2.0	2.0
	Cn-25	Carrier frequency proportional gain	0	0	0	0	0	0	0	0	0	0	0	0
	Cn-31	Motor phase-to-phase resistance Ω	0.164	0.133	0.110	0.074	0.027	0.051	0.036	0.032	0.023	0.020	0.022	0.014
	Cn-32	Torque compensation iron loss W	536	641	737	790	1800	1840	2900	2450	2500	2600	1850	3600
	Cn-33	Torque compensation limit V	100	100	100	100	100	100	100	100	100	100	100	100
	Cn-37	Momentary power loss assurance time s	2.0	2.0	2.0	2.0	2.0	2.0	2.0	2.0	2.0	2.0	2.0	2.0
	Cn-40	Minimum baseblock time s	1.0	1.0	1.0	1.0	1.0	1.0	2.0	2.0	2.0	2.0	2.0	2.0
	Cn-41*	V/F during speed search %	100	100	100	80	80	80	80	80	80	80	80	80

* The allowable maximum carrier frequency of 440V class 100HP to 215HP are to be as follows:

440V Horse Power	100HP	125HP	150HP	175HP	215HP
Max. Allowable Carrier Frequency	8kHz	6kHz	6kHz	5kHz	10kHz

* In PG mode, the function of Cn-41 is disabled.

2. SL

Parameter No.	Name	LCD Display (English)	Description	Factory Setting	Change During Operation	Valid Access Levels			
						GP	SL	PID	PG
Sn-01	Inverter Capacity Selection	Sn-01=29 440V 25HP	Inverter Capacity Selection	*1		1	2	1	1

Inverter Capacity Selection

220V Class

Name			Data of Sn-01							
			00	01	02	03	04	05	06	07
Inverter rating	HP		0.5	1	2	3	5	7.5	10	15
Inverter rated capacity	kVA		1.4	2.1	2.7	4.1	6.9	10.3	13.7	20.6
Max. applicable motor capacity	HP (kW)		0.5 (0.4)	1 (0.75)	2 (1.5)	3 (2.2)	5 (3.7)	7.5 (5.5)	10 (7.5)	15 (11)
Inverter rated current	A		3.2	4.8	6.4	9.6	16	24	32	48
Factory Setting	Cn-09	Motor rated current A	1.9	3.4	6.1	8.7	13.5	20.1	25.1	36.7
	Cn-23	Carrier frequency upper limit kHz	15.0	15.0	15.0	15.0	15.0	15.0	15.0	15.0
	Cn-24	Carrier frequency lower limit kHz	15.0	15.0	15.0	15.0	15.0	15.0	15.0	15.0
	Cn-25	Carrier frequency proportional gain	0	0	0	0	0	0	0	0
	Cn-31	Motor phase-to-phase resistance Ω	11.760	5.732	2.466	1.600	0.707	0.398	0.222	0.230
	Cn-32	Motor leakage inductance mH	42.24	19.07	13.40	9.81	6.34	4.22	2.65	2.23
	Cn-33	Torque limit %	150	150	150	150	150	150	150	150
	Cn-37	Momentary power loss assurance time s	0.7	1.0	1.0	1.0	2.0	2.0	2.0	2.0
	Cn-40	Minimum baseblock time s	0.5	0.5	0.5	0.5	0.5	0.7	0.7	0.7
	Cn-41	V/F during speed search %	100	100	100	100	100	100	100	100
bn-08	Rated slip of motor Hz	2.9	2.5	2.6	2.9	3.3	1.5	1.3	1.7	

Inverter Capacity Selection

220V Class

Name		Data of Sn-01									
		08	09	0A	0B	0C	0D	0E	0F		
Inverter rating		HP	20	25	30	40	50	60	75	100	
Inverter rated capacity		kVA	27.4	34	41	54	68	78	95	130	
Max. applicable motor capacity		HP (kW)	20 (15)	25 (18.5)	30 (22)	40 (30)	50 (37)	60 (45)	75 (55)	100 (75)	
Inverter rated current		A	64	80	96	130	160	183	224	300	
Factory Setting	Cn-09	Motor rated current	A	50.3	62.9	72.9	96.7	124	143.5	183.5	230
	Cn-23	Carrier frequency upper limit	kHz	15.0	10.0	10.0	10.0	10.0	3.0*	3.0*	3.0*
	Cn-24	Carrier frequency lower limit	kHz	15.0	10.0	10.0	10.0	10.0	3.0*	3.0*	3.0*
	Cn-25	Carrier frequency proportional gain		0	0	0	0	0	0	0	0
	Cn-31	Motor phase-to-phase resistance	Ω	0.138	0.102	0.080	0.067	0.045	0.035	0.028	0.019
	Cn-32	Motor leakage inductance	mH	1.48	1.39	1.15	1.15	1.15	1.15	1.15	1.15
	Cn-33	Torque limit	%	150	150	150	150	150	150	150	150
	Cn-37	Momentary power loss assurance time	s	2.0	2.0	2.0	2.0	2.0	2.0	2.0	2.0
	Cn-40	Minimum baseblock time	s	0.7	1.0	1.0	1.0	1.0	1.0	1.0	1.0
	Cn-41	V/F during speed search	%	100	100	100	80	80	80	80	80
bn-08	Rated slip of motor	Hz	1.6	1.7	1.7	1.8	1.3	1.6	1.5	1.4	

* The allowable maximum carrier frequency is 10kHz

Inverter Capacity Selection

440V Class

Name		Data of Sn-01												
		20	21	22	23	24	25	26	27	28	29	2A		
Inverter rating	HP	0.5	1	2	3	5	7.5	10	15	20	25	30		
Inverter rated capacity	kVA	1.4	2.1	3.4	4.1	6.9	10.3	13.7	20.6	27.4	34	41		
Max. applicable motor capacity	HP (kW)	0.5 (0.4)	1 (0.75)	2 (1.5)	3 (2.2)	5 (3.7)	7.5 (5.5)	10 (7.5)	15 (11)	20 (15)	25 (18.5)	30 (22)		
Inverter rated current	A	1.6	2.6	4.0	4.8	8	12	16	24	32	40	48		
Factory Setting	Cn-09	Motor rated current	A	1.0	1.6	3.1	4.2	7	10.1	12.6	18.6	24.8	31.1	36.3
	Cn-23	Carrier frequency upper limit	kHz	15.0	15.0	15.0	15.0	15.0	15.0	15.0	15.0	15.0	10.0	10.0
	Cn-24	Carrier frequency lower limit	kHz	15.0	15.0	15.0	15.0	15.0	15.0	15.0	15.0	15.0	10.0	10.0
	Cn-25	Carrier frequency proportional gain		0	0	0	0	0	0	0	0	0	0	0
	Cn-31	Motor phase-to-phase resistance	Ω	47.02	22.929	9.629	6.333	2.735	1.776	1.151	0.634	0.436	0.308	0.239
	Cn-32	Motor leakage inductance	mH	168.7	80.76	53.25	40.03	24.84	16.87	10.59	8.93	5.90	5.54	4.59
	Cn-33	Torque limit	%	150	150	150	150	150	150	150	150	150	150	150
	Cn-37	Momentary power loss assurance time	s	1.0	1.0	1.0	1.0	2.0	2.0	2.0	2.0	2.0	2.0	2.0
	Cn-40	Minimum baseblock time	s	0.5	0.5	0.5	0.5	0.5	0.7	0.7	0.7	0.7	1.0	1.0
	Cn-41	V/F during speed search	%	100	100	100	100	100	100	100	100	100	100	100
bn-08	Rated slip of motor	Hz	2.7	2.6	2.5	3.0	3.2	1.5	1.3	1.7	1.6	1.7	1.7	

Inverter Capacity Selection

440V Class

Name		Data of Sn-01													
		2B	2C	2D	2E	2F	30	31	32	33	34	35	36		
Inverter HP	rating	40	50	60	75	100	125	150	175	215	250	300	400		
Inverter rated capacity	kVA	54	68	82	110	138	180	195	230	260	290	385	514		
Max. applicable motor capacity (kW)	HP	40 (30)	50 (37)	60 (45)	75 (55)	100 (75)	125	150 (110)	175	215 (160)	250 (185)	300 (220)	400 (300)		
Inverter rated current	A	64	80	96	128	165	192	224	270	300	340	450	600		
Factory Setting	Cn-09	Motor rated current	A	48.7	59.0	70.5	80	114	145	175	205	235	290	348	465
	Cn-23	Carrier frequency upper limit	kHz	10.0	10.0	10.0	10.0	3.0*	3.0*	3.0*	3.0*	3.0*	2.0	2.0	2.0
	Cn-24	Carrier frequency lower limit	kHz	10.0	10.0	10.0	10.0	3.0*	3.0*	3.0*	3.0*	3.0*	2.0	2.0	2.0
	Cn-25	Carrier frequency proportional gain		0	0	0	0	0	0	0	0	0	0	0	0
	Cn-31	Motor phase-to-phase resistance	Ω	0.164	0.133	0.110	0.074	0.027	0.051	0.036	0.032	0.023	0.020	0.022	0.014
	Cn-32	Motor leakage inductance	mH	3.59	2.60	2.26	0.49	0.49	0.49	0.49	0.49	0.49	0.49	0.49	0.49
	Cn-33	Torque limit	%	150	150	150	150	150	150	150	150	150	150	150	150
	Cn-37	Momentary power loss assurance time	s	2.0	2.0	2.0	2.0	2.0	2.0	2.0	2.0	2.0	2.0	2.0	2.0
	Cn-40	Minimum baseblock time	s	1.0	1.0	1.0	1.0	1.0	1.0	2.0	2.0	2.0	2.0	2.0	2.0
	Cn-41	V/F during speed search	%	100	100	100	80	80	80	80	80	80	80	80	80
bn-08	Rated slip of motor	Hz	1.8	1.3	1.6	1.5	1.4	1.4	1.4	1.4	1	2.9	1.2	1.2	

* The allowable maximum carrier frequency of 440V class 100HP to 215HP are to be as follows:

440V Horse Power	100HP	125HP	150HP	175HP	215HP
Max. Allowable Carrier Frequency	8kHz	6kHz	6kHz	5kHz	10kHz

■ V/F Pattern Selection **Sn-02**

Parameter No.	Name	LCD Display (English)	Description	Factory Setting	Change During Operation	Valid Access Levels			
						GP	SL	PID	PG
Sn-02	V/F Curve Selection	Sn-02=01 V/F Curve	V/F pattern Selection	01					

- V/F pattern is selected by the setting of Sn-02. When V/F pattern is selected, set input voltage of the inverter in Cn-01.

- Data 0 - E (of Sn-02): Change disabled

- Data F (of Sn-02): Change enabled

(V/F patterns are shown on the following pages).

- The V/F pattern is fixed to Sn-02=0F for the SL control mode; The users have to check the V/F pattern to meet the load application if switched to one of the other three control mode (GP, PID or PG) from SL control mode.
- To select the high starting torque V/F pattern for inverter mode of capacity 440V 100HP (75KW) or more is recommended.
- In the sensorless vector control mode (SL), if sufficient torque cannot be obtained at a low speed, change the V/F pattern setting of Cn-02 to Cn-08 to high starting V/F.

[Example]

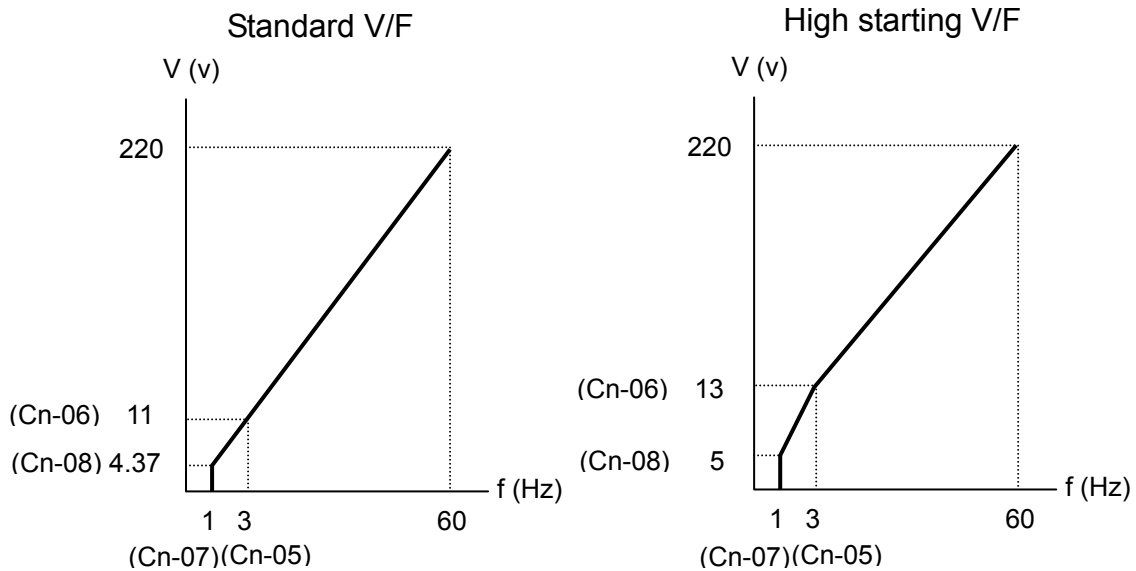

V/F Pattern of 220V Class* 3 to 60 HP

	Specifications	Sn-02	V/F Pattern +		Specifications	Sn-02	V/F Pattern +
General-purpose	50Hz	0		High Starting Torque*	50Hz	8	
	60Hz	1 F			60Hz	9	
	60Hz	2			60Hz	A	
	72Hz	3			90Hz	C	
Variable Torque Characteristics	50Hz	4		Rated Output Operation (Machine tool)	120Hz	D	
	50Hz	5			180Hz	E	
	60Hz	6					

* For 440V class, 2 times voltage value shown in table above.

+ Consider the following items as conditions for selecting a V/F pattern. They must be suitable for:

- (1) The voltage and frequency characteristics of the motor.
- (2) The maximum rotation speed of the motor.

× Select high starting torque only in the following conditions. Normally, this selection is not required.

- (1) The wiring distance is long [492ft (150m) and above].
- (2) Voltage drop at startup is large.
- (3) AC reactor is inserted in the input or output of the inverter.
- (4) A motor smaller than the maximum applicable inverter is used.

V/F Pattern of 220V Class* 75 and 100HP (75 to 400HP for 440V class)

Specifications		Sn-02	V/F Pattern +	Specifications		Sn-02	V/F Pattern +		
General-purpose	50Hz	0		High Starting Torque*	50Hz	8			
						9			
	60Hz	60Hz Saturation	1 F			60Hz	Low Starting torque	A	
		50Hz Saturation	2				High Starting torque	B	
	72Hz		3			90Hz	C		
	Variable Torque Characteristics	50Hz	Variable torque 1		4	Rated Output Operation (Machine tool)	120Hz	D	
Variable torque 2			5						
60Hz		Variable torque 3	6	180Hz	E				
		Variable torque 4	7						

* For 440V class, 2 times voltage value shown in table above.
 + Consider the following items as conditions for selecting a V/F pattern.
 They must be suitable for:
 (1) The voltage and frequency characteristics of the motor.
 (2) The maximum rotation speed of the motor.
 × Select high starting torque only in the following conditions. Normally, this selection is not required.
 (1) The wiring distance is long [492ft (150m) and above].
 (2) Voltage drop at startup is large.
 (3) AC reactor is inserted in the input or output of the inverter.
 (4) A motor smaller than the maximum applicable inverter is used.
 # Up to 100HP (75kW) for 220V class.

■ Operator Status **Sn-03**

Parameter No.	Name	LCD Display (English)	Description	Factory Setting	Change During Operation	Valid Access Levels			
						GP	SL	PID	PG
Sn-03	Display of Operator	Sn-03=0000 Operate Setting	0000: Setting and reading of An- , Bn- , Cn- , Sn- enabled 0101: Setting and reading of An- , Reading of Bn- , Cn- , Sn- enabled	0000					
	Constants Initialization		1110: Constants Initialigation (2-wire)*2 1111: Constants Initialigation (3-wire)*2						

- The ability to set or read the different groups of constants is determined by Sn-03 as show below.

Sn-03	DRIVE Mode		PRGM Mode		Remarks
	Setting	Reading	Setting	Reading	
0000	An, bn	Sn, Cn	An, bn, Sn, Cn	...	Factory setting
0101	An	bn, Sn, Cn	An	bn, Sn, Cn	*

* It is recommended that Sn-03 be set to **0101** and reading mode entered after test run adjustment.
Note: To read the Sn or Cn constants while in the DRIVE mode, depress the **[DSPL]** key with



key depressed.

- Initialization (Sn-03=1110, 1111)

After depressing the **[ENTER]** key, input the initial value of An- , bn- , Sn- , Cn- , (except Sn-01,Sn-02) into NV-RAM. When the value is written in without an error, "Entry accepted (End)" is displayed. When the value is written in with an error, " ** Error (Err)" alarm is displayed. The values of Sn-15 to -18 differ as follows between initializations with Sn-03 = 1110 and with Sn-03 = 1111.

Multi-function Terminal	1110 (2 Wire Sequence)	1111 (3 Wire Sequence)
Terminal 5 (Sn-15)	3* (Multi-step speed command 1)	0 (FWD/REV run select)
Terminal 6 (Sn-16)	4* (Multi-step speed command 2)	3 (Multi-step speed reference 1)
Terminal 7 (Sn-17)	6* (Jog frequency reference)	4 (Multi-step speed reference 2)
Terminal 8 (Sn-18)	8* (External baseblock command)	6 (Jog frequency reference)

* Values have been factory-set.

** contents depend on the parameter setting items.

■ Operation Mode Selection 1 Sn-04

Parameter No.	Name	LCD Display (English)	Description	Factory Setting	Change During Operation	Valid Access Levels			
						GP	SL	PID	PG
Sn-04	Operation Mode Select	Sn-04=0011 Stopping Method	-- 0: Frequency Command = Control circuit terminals 13 or 14 -- 1: Frequency Command = Frequency Command 1 (An-01)	0011					
	Stopping Method Selection		-- 0 -: RUN . STOP Command = Control circuit terminals -- 1 -: RUN . STOP Command = LCD Digital Operator 00- -: Stopping method = Ramp to stop 01- -: Stopping method =Coasting to stop 10- -: Stopping method =Full-range DC injection braking stop 11- -: Stopping method = Coasting stop (timer function provided)						

(1)1st digit (frequency reference selection)

1st digit = 0: Reference input from control circuit terminal 13 or 14 is the master speed frequency reference.

1st digit = 1: Frequency reference 1 (An-01) is the master speed frequency reference.

Note: For combination of multi-step speed operation, refer to pages 2-49.

(2)2nd digit (run command selection)

2nd digit = 0: Run command from control circuit terminal is accepted.

2nd digit = 1: Run command from the digital operator is accepted.

Valid run command and frequency references differ as shown in the table below, depending on the combination of the 1st and 2nd digits.

CONSTANT REFERENCE	SYSTEM CONSTANTS 4	2nd digit	1st digit	2nd digit	1st digit	2nd digit	1st digit	2nd digit	1st digit
		0	0	0	1	1	0	1	1
Control Terminal	Master Speed Frequency Reference	Control circuit terminal 13, 14		An-01		Control circuit terminal 13, 14		An-01	
	FWD Run Command (Terminal 1)					x		x	
	REV Run Command (Terminal 2)					x		x	
	External Fault (Terminal 3)								
	Fault Reset (Terminal 4)	*		*		*		*	
	Command of Terminal 5					+		+	
	Command of Terminal 6								
	Command of Terminal 7								
	Command of Terminal 8								
	Aux. Input								
	Fault Contact Output								
	Multi-function Contact Output								
	Multi-function PHC Output								
Operator	RUN Key		x		x				
	JOG Key		x		x				
	STOP Key		×		×				
	FWD/REV Key		x		x				
	>/RESET Key		*		*		*		*
	DRIVE/PRGM Key		Valid only when inverter stopped		Valid only when inverter stopped		Valid only when inverter stopped		Valid only when inverter stopped
	REF LED		Lit		OFF		Lit		OFF
	SEQ LED		Lit		Lit		OFF		OFF
Monitor display									

* Valid only when the inverter stops. (FWD run command, REV run command, and DC injection braking command are "open".)
 + FWD/REV run command is not accepted.

× When the STOP key is depressed, processing differs as follows, depending on the setting of the 1st digit of Sn-05.

1st digit = 0: During running by signals from control circuit terminals, the STOP key from the operator is accepted.

If the STOP key is depressed, the inverter stops according to the setting of 3rd and 4th digits of Sn-04, while the STOP LED indicator blinks. This stop command is held within the inverter until both the FWD run command and REV run command of control circuit terminals become "open", or another frequency reference is selected in the multi-step speed command or jog frequency reference section.

1st digit=1: During running by signals from control circuit terminals, the STOP key from the operator is not accepted.

(3)3rd digit, 4th digit (stop method selection)

Stop method differs by the setting of 3rd and 4th digits as shown below.

1 Sn-04 = 00 XX RAMP to stop

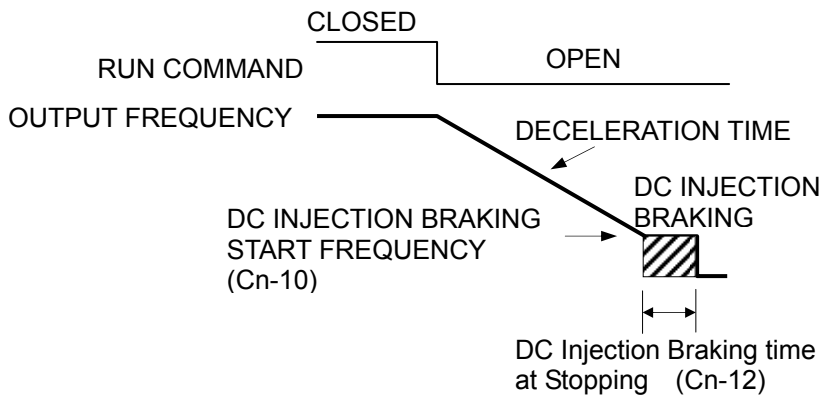

2 Sn-04 = 01 XX Coast to stop

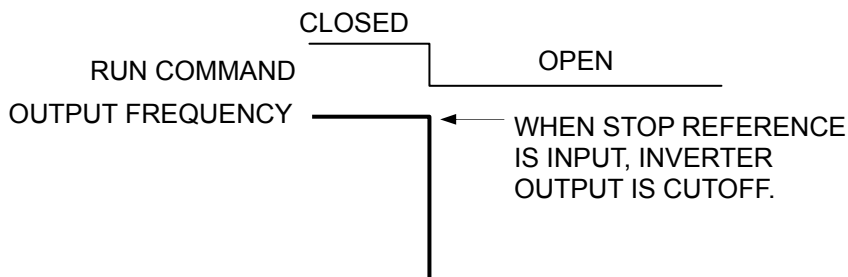

3 Sn-04 = 10 XX Full-range DC injection braking stop

DC injection braking time differs by the output frequency when stop command is input as shown below.

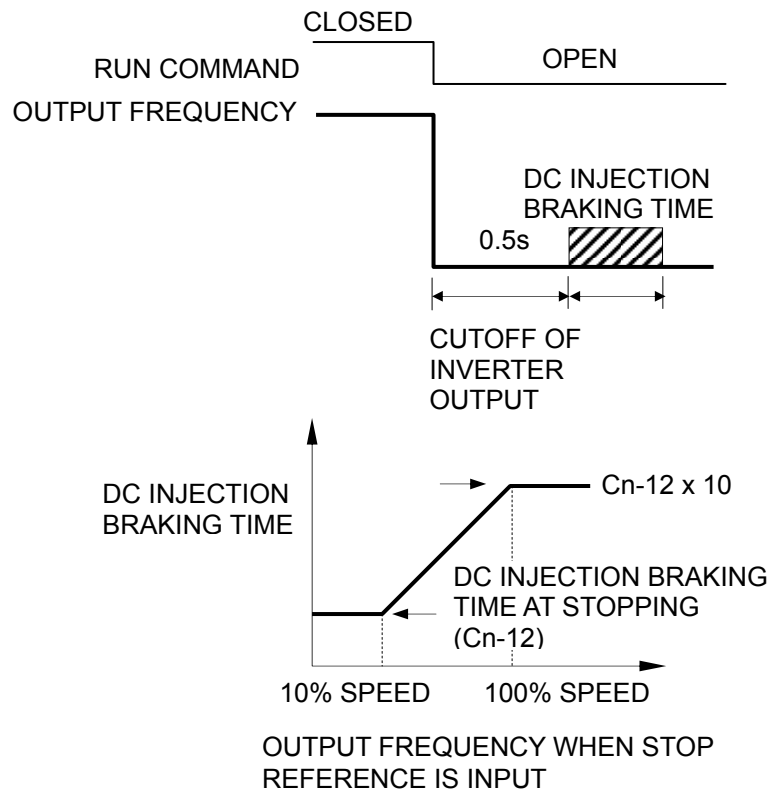

4 Sn-04 = 11 XX Coasting to a Stop (timer function provided)

Once stop command is input, run command is disregarded during T_1 time.

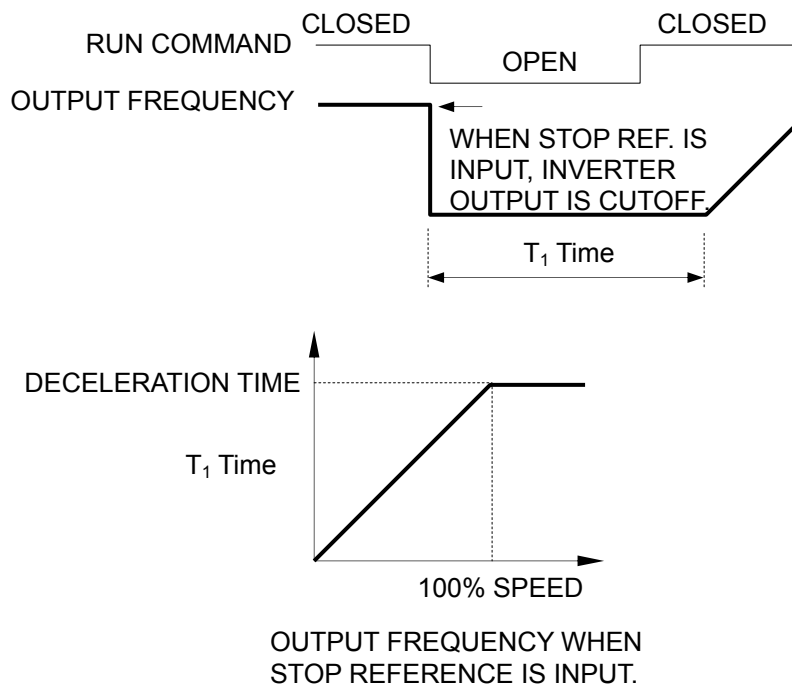

■ Operation Mode Selection 2 **Sn-05**

1. GP, SL, PID

Parameter No.	Name	LCD Display (English)	Description	Factory Setting	Change During Operation	Valid Access Levels			
						GP	SL	PID	PG
Sn-05	I/O terminal function selection	Sn-05=0000 I/O term. Fct	--0-: Stop key effective during operation from control terminal	0000		1	1	1	2
			--1-: Stop key effective during operation from control terminal						
			-0 -: Reverse run enabled						
			-1 -: Reverse run disabled						
-0 -: Control input terminals 1 ~ 8 are scanned twice.									
-1 -: Control input terminals 1 ~ 8 are scanned once.									
0- -: Selection of item to be analog output (terminals 21, 22)*3									
1- -: Selection of item to be analog output (terminals 21, 22)*3									

(1)1st digit

Select processing to be performed when the STOP key of the digital operator is depressed during running by control circuit terminals.

1st digit = 0: During running by signals from control circuit terminals, the STOP key from the digital operator is accepted. If the STOP key is depressed, the inverter stops according to the setting of the 3rd and 4th digits of Sn-04 while the STOP LED indicator blinks. This stop command is held within the inverter until both the FWD run command and REV run command of control circuit terminals become "open", or other frequency reference is selected in the multi-step speed command or jog frequency reference section.

1st digit = 1: During running by signals from control circuit terminals, the STOP key from the digital operator is not accepted.

(2)2nd digit (REV run prohibited)

2nd digit = 0: REV run command from control circuit terminals or the digital operator is accepted.

2nd digit = 1: REV run command from control circuit terminals or the digital operator is not accepted.

(3)3rd digit (selection of double scanning sequence command)

3rd digit = 0: Sequence command (control circuit terminals 1 to 8) is scanned twice.

3rd digit = 1: Sequence command (control circuit terminals 1 to 8) is scanned once.

(4)4th digit (selection of the multi-function analog output)

Multi-function analog output (control circuit terminals 21, 22) output signal can be selected by Sn-05 4th digit and Sn-09 2nd digit.

Sn-05 4th Digit	Sn-09 2nd Digit	Description
0	0	Outputs analog signal proportional to inverter output frequency. (Max. frequency/100%)
1	0	Outputs analog signal proportional to inverter current. (Rated current/100%)
0	1	Outputs analog signal proportional to inverter output voltage reference. (Cn-01/100%)
1	1	Outputs analog signal proportional to inverter output power. (Max motor capacity/100%)

2. PG

Parameter No.	Name	LCD Display (English)	Description	Factory Setting	Change During Operation	Valid Access Levels			
						GP	SL	PID	PG
Sn-05	I/O terminal function selection	Sn-05=0000 I/O term. Fct	--0: Stop key effective during operation from control terminal --1: Stop key effective during operation from control terminal	0000		1	1	1	2
			-0 -: Reverse run enabled -1 -: Reverse run disabled						
			-0 -: Control input terminals 1 ~ 8 are scanned twice. -1 -: Control input terminals 1 ~ 8 are scanned once.						
			0- -: Not used 1- -: Not used						

(1)1st, 2nd, 3rd, digit (functions same as GP, SL, PID control mode)

(2)4th digit (Not used)

[Note] The item to be output from multi-function analog output (Control circuit terminals 21-22) is set by bn-11 in the GP control mode. Please refer to bn-11.

■ Operation Mode Selection 3 Sn-06

Parameter No.	Name	LCD Display (English)	Description	Factory Setting	Change During Operation	Valid Access Levels			
						GP	SL	PID	PG
Sn-06	S-curve and frequency Command characteristics	Sn-06=0000 S-curve Cmd. Char.	--00: S curve=0.2sec --01: S curve=0.0sec (NO S curve) --10: S curve=0.5sec --11: S curve=1.0sec -0 --: Reference command has forward characteristics (0-10V or 4-20mA/0~100%) -1 --: Reference command has reverse characteristics (0-10V or 4-20mA/100~0%) 0 --: Stop by reference input when frequency reference is missing 1 --: Operation to continue with 80% of frequency reference when frequency reference is missing	0000					

(1)1st digit, 2nd digit (S-curve selection of soft starter)

The S-curve characteristics of the soft starter depend on the setting of the 1st and 2nd digits as follows:

2nd digit	1st digit	Contents
0	0	The S-curve characteristic is 0.2 second.
0	1	No S-curve characteristics.
1	0	The S-curve characteristic is 0.5 second.
1	1	The S-curve characteristic is 1 second.

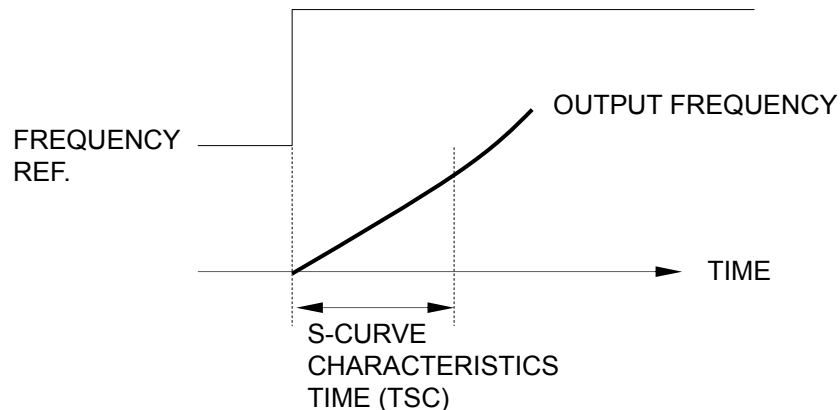

Note: S-curve characteristic time refers to the time from acceleration rate 0 to the time when a normal acceleration rate determined by a specified acceleration time is obtained.

(a)Time chart at FWD/REV run change with S-curve characteristic

The figure below shows the time chart at FWD/REV run change during deceleration and stop.

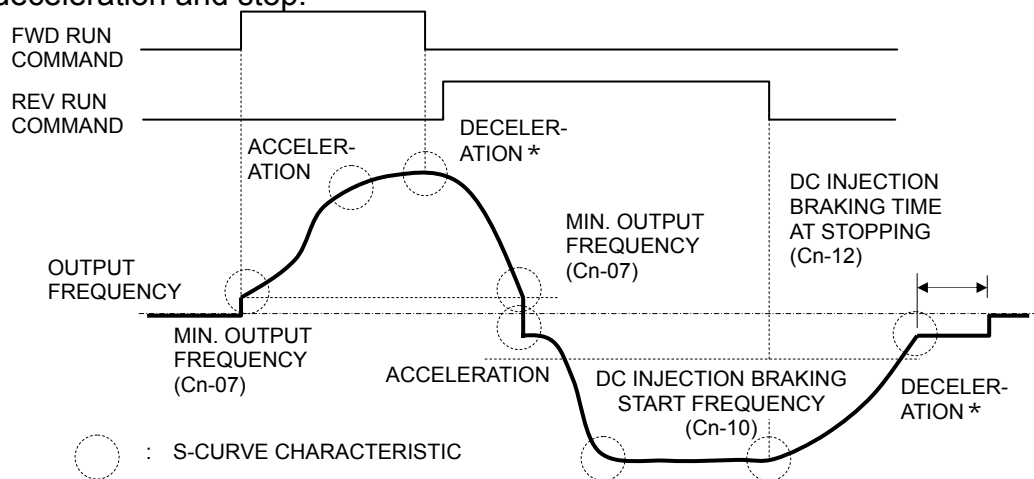

* When 1st and 2nd digits are 00, no S-curve characteristic at completion of deceleration.

(b) The chart at FWD/REV run change without S-curve characteristic

The figure below shows the time chart at FWD/REV run change during deceleration and stop.

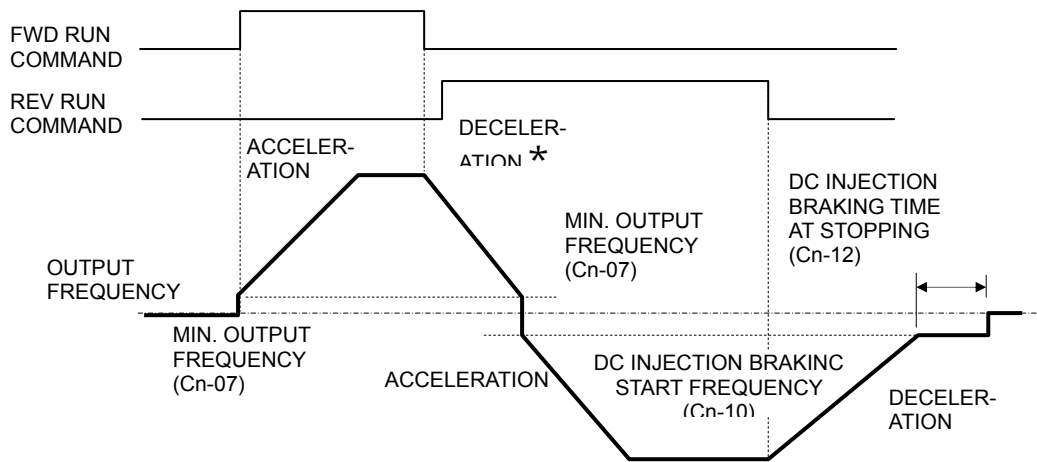

(2)3rd digit (reverse characteristic selection)

The input characteristics of the master speed frequency reference depend on the set value as follows. For the reverse characteristic, only + input is valid.

3rd digit = 0: Normal characteristic (0-10V or 4-20mA/0-100%)

3rd digit = 1: Reverse characteristic (10-0V or 20-4mA/0-100%)

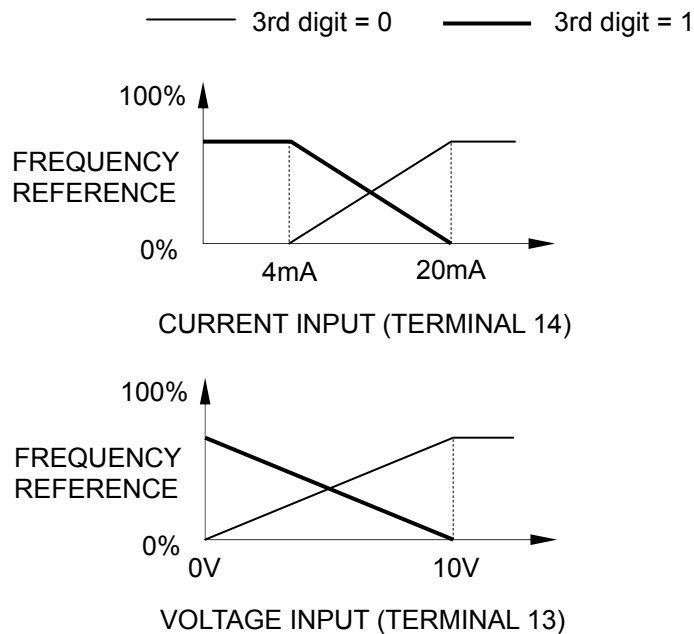

(3)4th digit (operation selection when frequency reference is missing)

4th digit = 0: Normal operation (varies with change of reference)

4th digit = 1: Operation continues with 80% frequency.

When 4th digit = 1 is set, the current master speed frequency reference is compared at all times with the one that occurred 0.4 second before. When the current master speed frequency reference goes below 10% of the one that occurred 0.4 second before, operation continues with 80% (80% frequency) of the master speed frequency reference of the prior one. Consequently, the master speed frequency reference of the previous one (0.4 second before) is used as the current frequency reference.

In the following cases, this operation is released and the inverter returns to normal operation:

- Master speed frequency reference exceeding 80% frequency is input.
- Stop reference is input.
- Reference is missing during operation at less than 5% of frequency.

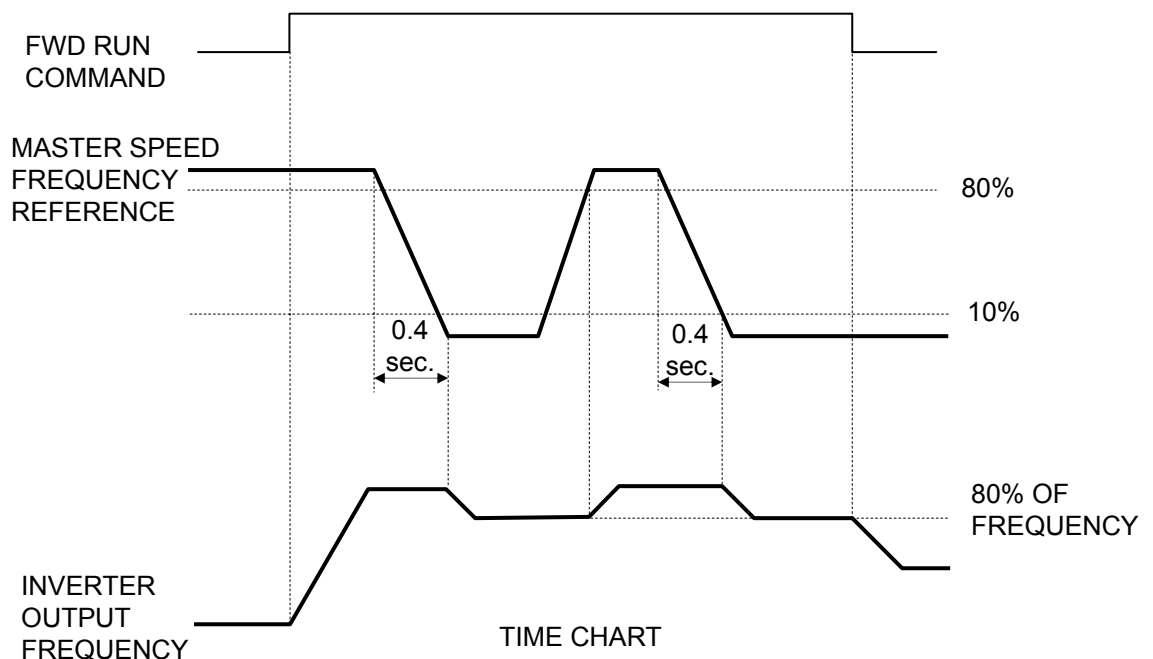

■ Operation Mode Selection 4 **Sn-07**

1. GP, PID, PG

Parameter No.	Name	LCD Display (English)	Description	Factory Setting	Change During Operation	Valid Access Levels			
						GP	SL	PID	PG
Sn-07	Overtorque Detection	Sn-07=0000 Over Tq. Detect	--0: Overtorque detection disabled	0000		1	2	1	1
			--1: Overtorque detection enabled						
			-0 -: Enabled only if at agreed frequency						
			-1 -: Enable during operation (except during DC injection)						
			-0 -: Operation continued after overtorque is detected						
-1 -: Coasts to stop if overtorque is detected									
0- -: Overtorque detection with current									
1- -: Overtorque detection with torque									

Define the operation at overtorque detection. Overtorque is detected by the following formula:

Inverter output current B overtorque detection level (Cn-26, Initial value: 160%)

(Detection time Cn-27, Initial value: 0.1 second, Hysteresis fixed at 10%)

(1)1st digit

1st digit = 0: Overtorque is not detected.

1st digit = 1: Overtorque is detected.

(2)2nd digit

2nd digit = 0: Overtorque is detected only during agreed frequency.

2nd digit = 1: Overtorque is detected during stop or during running except for DB.

(3)3rd digit

3rd digit = 0: When overtorque is detected, "Over Torque (OL3) Alarm" blinks on the digital operator and the operation continues.

3rd digit = 1: When overtorque is detected, "Over Torque (OL3) Fault" is displayed on the digital operator and the inverter output is shut OFF. Fault contact signal is output. (Treated as a fault).

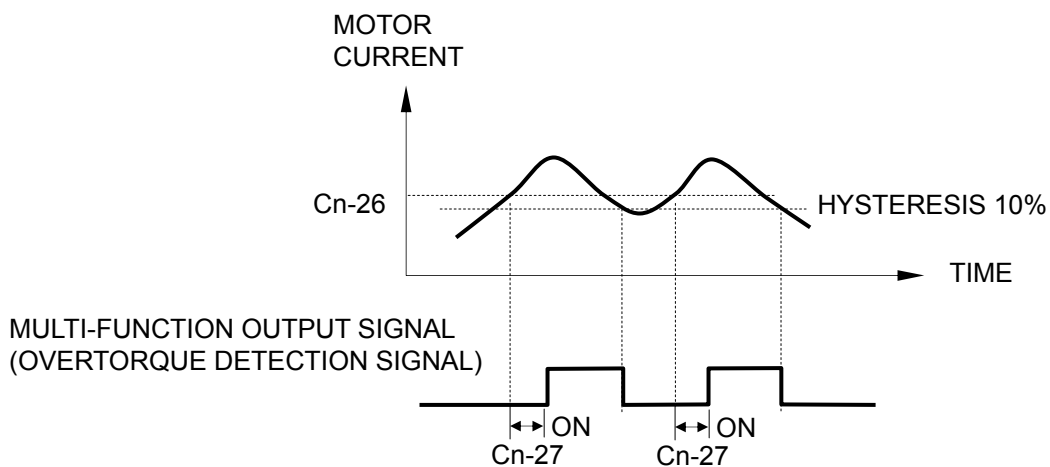

Setting either Sn-20 or 22 to "0B" enables signal to be output at overtorque detection.

(4)4th digit (Not used)

2. SL

Parameter No.	Name	LCD Display (English)	Description	Factory Setting	Change During Operation	Valid Access Levels			
						GP	SL	PID	PG
Sn-07	Overtorque Detection	Sn-07=0000 Over Tq. Detect	--0: Overtorque detection disabled	0000		1	2	1	1
			--1: Overtorque detection enabled						
			-0-: Enabled only if at agreed frequency						
			--1 -: Enable during operation (except during DC injection)						
			-0- -: Operation continued after overtorque is detected						
			-1- -: Coasts to stop if overtorque is detected						
0- -: Overtorque detection with current									
1- -: Overtorque detection with torque									

(1)1st, 2nd, 3rd digit (functions same as GP, PID,PG control mode)

(2)4th digit

4th digit = 0: Overtorque detected with current.

4th digit = 1: Overtorque detected with torque.

■ Operation Mode Selection 5 **Sn-08**

1. GP, SL

Parameter No.	Name	LCD Display (English)	Description	Factory Setting	Change During Operation	Valid Access Levels			
						GP	SL	PID	PG
Sn-08	Option Card/Inverter Function Selection	Sn-08=0000 AI/DI & SI-M Card	--0: Frequency reference input by option card (AI-14B, DI-08 or SI-M)	0000		1	1	2	3
			--1: Frequency reference input by digital operator or control circuit input terminals						
			--0 -: RUN/STOP command input by option card (AI-14B, DI-08 or SI-M)						
			--1 -: RUN/STOP command input by digital operator or control circuit input terminals						
			00- -: SI-M communication fault, deceleration to stop (bn-02)						
			01- -: SI-M communication fault, coast to stop						
			10- -: SI-M communication fault, deceleration to stop (bn-04)						
			11- -: SI-M communication fault, continue to run						

(1)1st digit (option/inverter change)

Specify whether option card or inverter frequency reference is used for operation.

1st digit = 0: Option card frequency reference is accepted.

1st digit = 1: Frequency reference from inverter control circuit terminals or the digital operator is accepted.

(2)2nd digit (run command option/inverter change)

Select whether operation is performed by the option card or inverter run command.

2nd digit = 0: Run command from option card received.

2nd digit = 1: Run command from inverter control circuit terminal or digital operator received.

(3)3rd digit, 4th digit (selection of stopping method at communication error detection)

Stopping method at communication error detection can be selected by communication interface card (SI-M).

4th digit	3rd digit	Contents
0	0	Ramp to stop by bn-02 (major fault)
0	1	Coast to stop (major fault)
1	0	Ramp to stop by bn-04 (major fault)
1	1	Operation to continue (minor fault)

2. PID

Parameter No.	Name	LCD Display (English)	Description	Factory Setting	Change During Operation	Valid Access Levels			
						GP	SL	PID	PG
Sn-08	Option Card/Inverter Function & Energy Saving Selection	Sn-08=0000 AI/DI & Eg. Saving	--0: Frequency reference input by option card (AI-14B, DI-08 or SI-M)	0000		1	1	2	3
			--1: Frequency reference input by digital operator or control circuit input terminals						
			--0: RUN/STOP command input by option card (AI-14B, DI-08 or SI-M)						
			--1: RUN/STOP command input by digital operator or control circuit input terminals						
			-0 -: Auto Energy Saving function ineffective (normal V/F control method)						
-1 -: Auto Energy Saving function effective									
0- -: Not used									
1- -: Not used									

(1)1st, 2nd, digit (functions same as GP, SL control mode)

(2)3rd digit (Auto Energy Saving selection)

3rd digit = 0: Auto Energy Saving (AES) function ineffective

3rd digit = 1: Auto Energy Saving function effective. (ref. To Appendix B)

(3)4th digit (Not used)

3. PG

Parameter No.	Name	LCD Display (English)	Description	Factory Setting	Change During Operation	Valid Access Levels				
						GP	SL	PID	PG	
Sn-08	Option Card/Inverter Function Selection	Sn-08=0000 AI/DI Card	--0: Frequency reference input by option card (AI-14B, DI-08 or SI-M)	0000		1	1	2	3	
			--1: Frequency reference input by digital operator or control circuit input terminals							
			--0 -							} Not used
			--1 -							
			-0 - -							
-1 - -										
0 - - -										
1 - - -										

(1)1st digit (functions same as GP, SL control mode)

(2)2nd, 3rd, 4th digit (Not used)

■ Operation Mode Selection 6 **Sn-09**

1. GP

Parameter No.	Name	LCD Display (English)	Description	Factory Setting	Change During Operation	Valid Access Levels			
						GP	SL	PID	PG
Sn-09	Analog Output Selection and Slip Compensation	Sn-09=0000 ~Output Select	-- 0: Analog output (terminal 21 - 22) depends on Sn-05 4th digit and Sn-09 2nd digit.	0000		1	2	3	
			-- 1: Analog output (terminal 21 - 22) is set by SI-M card.						
			-- 0: Analog output (terminal 21 - 22)						
			-- 1: Analog output (terminal 21 - 22)						
			-0 -- -1 -- 0 -- 1 --						

(1) 1st digit (selection of analog output)

Multi-function analog output signal contents can be set either by the inverter or option card.

1st digit = 0: Output according to Sn-05 4th digit and Sn-09 2nd digit setting contents.

1st digit = 1: Output according to contents set by communication interface card (SI-M).

(2) 2nd digit (selection of multi-function analog output signal)

Multi-function analog output (control circuit terminals 21 - 22) output signal can be selected according to Sn-05 4th digit and Sn-09 2nd digit set value. Output signal level is set by bn-11.

Sn-05 4th Digit	Sn-09 2nd Digit	Description
0	0	Outputs analog signal proportional to inverter output frequency. (Max. frequency/100%)
1	0	Outputs analog signal proportional to inverter current. (Rated current/100%)
0	1	Outputs analog signal proportional to inverter output voltage reference. (Cn-01/100%)
1	1	Outputs analog signal proportional to inverter output power. (Max. applicable motor capacity/100%)

(3) 3rd, 4th digit (Not used)

2. SL

Parameter No.	Name	LCD Display (English)	Description	Factory Setting	Change During Operation	Valid Access Levels			
						GP	SL	PID	PG
Sn-09	Analog Output Selection and Slip Compensation	Sn-09=0000 ~Output Select	--0: Analog output (terminal 21 - 22) depends on Sn-05 4th digit and Sn-09 2nd digit.	0000		1	2	3	
			--1: Analog output (terminal 21 - 22) is set by SI-M card.						
			-0 -: Analog output (terminal 21 - 22)						
			-1 -: Analog output (terminal 21 - 22)						
			-0 -: Not used						
			-1 -: Not used						
0--: No slip compensation during regenerating									
1--: Slip compensation even during regenerating									

(1)1st digit (functions same as GP control mode)

(2)2nd digit (selection of multi-function analog output signal)

Multi-function analog output (control circuit terminals 21 - 22) output signal can be selected according to Sn-05 4th digit and Sn-09 2nd digit set value. Output signal level is set by bn-11.

Sn-05 4th Digit	Sn-09 2nd Digit	Description
0	0	Outputs analog signal proportional to inverter output frequency. (Max. frequency/100%)
1	0	Outputs analog signal proportional to inverter current. (Rated current/100%)
0	1	Outputs analog signal proportional to inverter output voltage reference. (Cn-01/100%)
1	1	Outputs analog signal proportional to inverter output torque. (10V/250% motor rated torque)

(3)3rd digit (Not used)

(4)4th digit (Slip compensation during regenerating selection)

4th digit = 0: No slip compensation during regenerating.

4th digit = 1: Slip compensation even during regenerating.

3. PID

Parameter No.	Name	LCD Display (English)	Description	Factory Setting	Change During Operation	Valid Access Levels			
						GP	SL	PID	PG
Sn-09	Analog Output Selection and Slip Compensation	Sn-09=0000 ~Output Select	--0 } --1 } Not used	0000		1	2	3	
			-0 -: Analog output (terminal 21 - 22)						
			-1 -: Analog output (terminal 21 - 22)						
			-0-- } -1-- } 0-- } 1-- } Not used						

(1)1st digit (Not used)

(2)2nd digit (functions same as GP control mode)

(3)3rd, 4th digit (Not used)

■ Protective Characteristic Selection 1 **Sn-10**

Parameter No.	Name	LCD Display (English)	Description	Factory Setting	Change During Operation	Valid Access Levels			
						GP	SL	PID	PG
Sn-10	Stall Prevention	Sn-10=0000 Stall Select	-- 0: Stall prevention during acceleration enabled	0000					
			-- 1: Stall prevention during acceleration disabled						
			- 0 -: Stall prevention during deceleration enabled						
			- 1 -: Stall prevention during deceleration disabled						
			- 0 -: Stall prevention during running enabled						
- 1 -: Stall prevention during running disabled									
			0- -: Decel time during stall prevention (bn-02 set value)						
			1- -: Decel time during stall prevention (bn-04 set value)						

(1) 1st digit (selection of stall prevention during acceleration)

1st digit = 0: Stall prevention during acceleration is enabled.

1st digit = 1: Stall prevention during acceleration is disabled.

The function of stall prevention during acceleration automatically extends acceleration according to load status (inverter output current), thus preventing the motor from stalling during acceleration. The stall prevention level during acceleration in a constant output area is reduced as follows:

$$\text{Acceleration stall prevention level of constant output field} = \frac{\text{acceleration stall prevention level (Cn-28)} \times \text{maximum voltage frequency (Cn-04)}}{\text{output frequency}}$$

When the 1st digit of Sn-10 is 1, the output frequency increases at the rate determined by acceleration time:

(2) 2nd digit (selection of stall prevention during deceleration)

2nd digit = 0: Stall prevention during deceleration is enabled.

2nd digit = 1: Stall prevention during deceleration is disabled.

The function of stall prevention during deceleration automatically extends deceleration time according to the magnitude of the main circuit DC voltage, thus preventing overvoltage during deceleration.

When the 2nd digit of Sn-10 is 1, the output frequency decreases at the rate determined by deceleration time. For positioning applications, specify "stall prevention during deceleration not provided" (2nd digit = 1) in order to obtain stopping accuracy. With large inertia loads, use a braking resistor to prevent overvoltage.

(3) 3rd digit (stall prevention during running)

3rd digit = 0: Stall prevention during running is enabled.

3rd digit = 1: Stall prevention during running is disabled.

Stall prevention operation during running starts decelerating when the output current reaches 100ms or greater than the set value of Cn-30 during frequency coincidence (operation level of stall prevention during running). The inverter decelerates as long as the output current exceeds the set value of Cn-30 (operation level of stall prevention during running). When the output current goes below the set value, the inverter reaccelerates. The deceleration time selected in the 4th digit of Sn-10 is taken. Even during stall prevention while running, stall prevention during deceleration and stall prevention during acceleration are enabled.

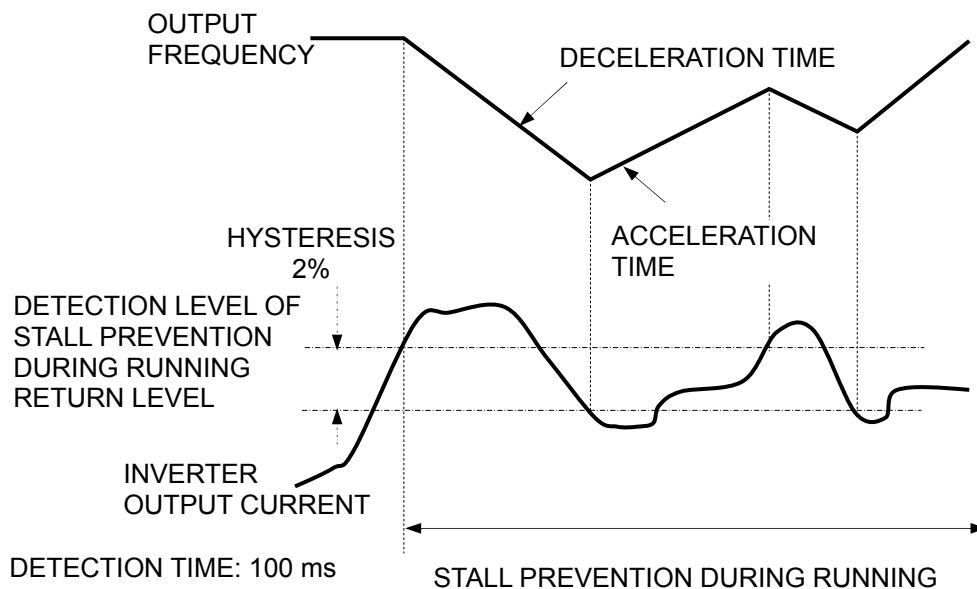

(4) 4th digit (selection of deceleration time during stall prevention while running)

4th digit = 0: The inverter decelerates for the deceleration time specified in bn-02.

4th digit = 1: The inverter decelerates for the deceleration time specified in bn-04.

■ Protective Characteristic Selection 2 **Sn-11**

Parameter No.	Name	LCD Display (English)	Description	Factory Setting	Change During Operation	Valid Access Levels				
						GP	SL	PID	PG	
Sn-11	Retry and momentary power loss protection	Sn-11=0000 Retry & Ride-Thru	--0: Not used	0000						
			--1: Not used							
			--0 -: Fault contact is not energized during Retry operation							
			--1 -: Fault contact is energized during Retry operation							
			-0 -: Operation stopped by momentary power loss detection (UV1)							
			-1 -: Operation continues after momentary power loss							
0 -: Not used	1 -: Not used									

(1) 1st digit (Not used)

(2) 2nd digit (fault contact signal during auto reset/restart operation)

2nd digit = 0: A fault contact signal is not output during auto reset/restart operation.

2nd digit = 1: A fault contact signal is output during auto reset/restart operation.

(3) 3rd digit (operation continued at momentary power loss)

3rd digit = 0: When momentary power loss is detected, "DC Volt. Low (Uv1) Fault" occurs and the inverter output is shut OFF.

3rd digit = 1: If momentary power loss time is within momentary power loss ride-thru time (Cn-37), the operation continues after the momentary power loss. If the momentary power loss ride-thru time is exceeded, undervoltage fault "DC Volt. Low (Uv1) Fault" occurs and the inverter output is shut OFF.

Notes:

- When the 3rd digit = 1, be sure not to shut OFF the external sequence signal. (e.g. FWD, REV)
- For lifters, do not use this function. (the 3rd digit = 0)

(4) 4th digit (Not used)

■ Protective Characteristic Selection 3 **Sn-12**

Parameter No.	Name	LCD Display (English)	Description	Factory Setting	Change During Operation	Valid Access Levels			
						GP	SL	PID	PG
Sn-12	External Fault Function Selection	Sn-12=0100 External Fault	--0: External fault input (terminal 3) is NO-contact input --1: External fault input: is NC-contact input -0 -: External fault signal: always detected -1 -: External fault signal: detected during running only 00- -: External fault detected: ramp to stop (major fault) by bn-02 set value 01- -: External fault detected: Coasting to stop (major fault) 10- -: External fault detected: ramp to stop (major fault) by bn-04 set value 11- -: External fault detected: operation to continue (major fault)	0100					

When an external fault signal of terminal 3 is input, “External Fault 3 (EF3) Fault” is displayed and a fault contact signal is output immediately. The inverter stops according to the setting of the 3rd and 4th digits. The external fault signal is held within the inverter until a fault reset signal is input.

(1) 1st digit (level selection of external fault signal)

1st digit = 0: NO contact input (when "closed", external fault operation is performed).

1st digit = 1: NC contact input (when "open", external fault operation is performed).

(2) 2nd digit (acceptance of external fault signal)

2nd digit = 0: External fault signals are always accepted.

2nd digit = 1: External fault signals are accepted only during running.
(Not accepted during baseblock).

(3) 3rd digit, 4th digit (selection of processing at external fault detection)

4th digit	3rd digit	Contents
0	0	Ramp to stop by bn-02 (major fault)
0	1	Coast to stop (major fault)
1	0	Ramp to stop by bn-04 (major fault)
1	1	Operation to continue (minor fault)

■ Control Mode Selection **Sn-13**

Parameter No.	Name	LCD Display (English)	Description	Factory Setting	Change During Operation	Valid Access Levels			
						GP	SL	PID	PG
Sn-13	Control Mode Select	Sn-13=00 V/F Ctrl mode	00: GP - V/F Control mode 01: SL - Sensorless Vector Control mode 10: PID - PID With Auyo Energy Saving Control mode 11: PG - V/F+PG closed loop Control mode	00					

- The four control mode can be selected by parameter Sn-13 as below.

Sn-13 setting	LCD Display (English)	Descriptions
00	Sn-13=00 V/F Ctrl Mode	GP: V/F Control mode (factory setting)
01	Sn-13=01 SL Ctrl Mode	SL: Sensorless Vector Control mode
10	Sn-13=10 PID Ctrl Mode	PID: PID With Auyo Energy Saving Control mode
11	Sn-13=11 PG Ctrl Mode	PG: V/F+PG closed loop Control mode

- When the required control mode is selected by Sn-13 setting, the selected control mode functions are effective only after turning off power supply till the display of digital operator (LCD or LED digital operator) is off, then turn on the power supply again.

■ Protective Characteristic Selection 5 **Sn-14**

Parameter No.	Name	LCD Display (English)	Description	Factory Setting	Change During Operation	Valid Access Levels			
						GP	SL	PID	PG
Sn-14	Electronic Thermal Overload Protection	Sn-14=0000 Over Load Select	--0: Motor overload (OL1) protection: effective	0000					
			--1: Motor overload (OL1) protection: ineffective						
			-0 -: Motor overload protection: standard motor						
			-1 -: Motor overload protection: Inverter duty motor						
			-0 -: Motor overload protection time constants are standard time (8 minutes)						
-1 -: Motor overload protection time constants are short-time (5 minutes)									
			0--: Inverter overload (OL2) protection 103% continuous, 150% for one minute*2						
			1--: Inverter overload (OL2) protection 113% continuous, 123% for one minute*2						

(1) 1st digit (motor protection)

1st digit = 0: Electronic thermal motor protection is enabled.

1st digit = 1: Electronic thermal motor protection is disabled.

(2) 2nd digit (selection of electronic thermal characteristics)

2nd digit = 0: Electronic thermal characteristics are in accordance with reduced torque motor (standard motor).

2nd digit = 1: Electronic thermal characteristics are in accordance with constant torque motor (special motor).

(3) 3rd digit (electronic thermal time constant)

3rd digit = 0: Used for standard motor and special motor (standard ratings).

3rd digit = 1: Used for motors other than the above (short-time ratings).

(4) 4th digit (selection of inverter protective characteristics)

4th digit = 0: When inverter output current exceeds 103%, the inverter protection electronic thermal characteristics start operating: Inverter protection "Inverter overload (OL2) Fault" operates at 150% for one minute to shut OFF inverter output.

4th digit = 1: When inverter output current exceeds 113%, the inverter protection electronic thermal characteristics start operating: Inverter protection "Inverter overload (OL2) Fault" operates at 123% for one minute to shut OFF inverter output.

Note: This function is effective only for inverter models with capacity 40HP (30kW) or larger (230V class), and 75HP (55kW) or larger (460V class).

Multi - Function Contact Input Selection **Sn-15 to Sn-18**

Parameter No.	Name	LCD Display (English)	Description	Factory Setting	Change During Operation	Valid Access Levels			
						GP	SL	PID	PG
Sn-15	Terminal 5 Function	Sn-15=03 Term.5 Function	00~66 Selects terminal 5 function (factory preset for multi-step speed reference 1)	03					
Sn-16	Terminal 6 Function	Sn-16=04 Term.6 Function	00~66 Selects terminal 6 function (factory preset for multi-step speed reference 2)	04					
Sn-17	Terminal 7 Function	Sn-17=06 Term.7 Function	00~66 Selects terminal 7 function (factory preset for jog frequency reference)	06					
Sn-18	Terminal 8 Function	Sn-18=08 Term.8 Function	00~66 Selects terminal 8 function (factory preset for external baseblock by NO contact input)	08					

Set Value	Function	LCD Display (English)	Description	Valid Access Levels			
				GP	SL	PID	PG
00	FWD / REV RUN selection	3-Wire RUN	Open: FWD run, Closed: REV run, } 3-wire sequence mode (00 set in Sn-15) terminal 1-run , 2-stop, 5 FWD / REV selection.				
01	Operation signal selection Local/Remote	LOC/REMOT Control	Open: Operated according to setting of Sn-04 1st and 2nd digits. Closed: Operated by frequency reference and run command from digital operator.				
02	Option / inverter reference selection	Opt. Card Switch	Open: Operated by frequency reference from option card. Closed: Operated by frequency reference from the inverter.				
03	Multi-step speed reference 1	Multi-Fct Command 1	Combination of multi-step speed references 1 to 3 correspond to speed reference (master speed An-01) and speed references 2 to 8 (An-02 to 08).	1	1	2	2
04	Multi-step speed reference 2	Multi-Fct Command 2		1	1	2	2
05	Multi-step speed reference 3	Multi-Fct Command 3		1	1		
06	Jog frequency reference selection	JOG Command	Closed: Jog frequency reference is selected.	1	1	2	2
07	Accel / decel time selection	Acc. & Dec Switch	Open: Accelerates/decelerates with ACCEL time 1 and DECEL time 1. (bn-01, bn-02 set values) Closed: Accelerates/decelerates with ACCEL time 2 and DECEL time 2. (bn-03, bn-04 set values)				
08	External baseblock (NO contact input)	Ext. B.B. NO_Cont.	Closed: Inverter output is shut OFF. (Frequency reference is held).				
09	External baseblock (NC contact input)	Ext. B.B. NC_Cont.	Open: Inverter output is shut OFF. (Frequency reference is held).				
0A	Accel / decel speed prohibit command (HOLD command)	Inhibit Acc. & Dec.	Frequency reference is held. (SFS operation is stopped).				
0B	Inverter overheat alarm	Over Heat Alarm	Closed: OH2 blinks on operator and operation continues. (Mirror fault)				
0C	Multi-function analog input enabled / disabled	 Cmd. Control	Closed: Multi-function analog input is enabled. (terminal 16) Open: Multi-function analog input is disabled. (terminal 16)				

Set Value	Function	LCD Display (English)	Description	Valid Access Levels			
				GP	SL	PID	PG
0D	No speed control	Speed Ctrl Select	Closed: Speed control is not provided.				
0E	Integral valve reset in speed control	Integral Reset	Closed: Integral valve is reset in speed control				
0F	Not used	Reserved	-	-	-	-	-
10	UP command	UP Command	Closed: Output frequency increment				
11	DOWN command	DOWN Command	Closed: Output frequency decrement				
12	FJOG command	Forward Jog	Closed: Forward jog run FWD LED lights. Display: 6Hz				
13	RJOG command	Reverse Jog	Closed: Reverse jog run Digital operator REV LED does not light. Display: 6Hz				
14 to 1F	Not used	Reserved	—	-	-	-	-
20 to 2F	External fault 5	External fault 5	External fault signal input				
30 to 3F	External fault 6	External fault 6					
40 to 4F	External fault 7	External fault 7					
50 to 5F	External fault 8	External fault 8					
60	DC injection braking command (JOG with priority)	DC Braking Command	Closed: DC injection braking applied when the frequency output is less than the DC injection start frequency and the DC injection braking command is closed.				
61	Search 1	Max. Freq. Sp_Search	Closed: Search from max frequency				
62	Search 2	Set Freq. Sp_Search	Closed: Search from set frequency				
63	Energy-saving operation	Erg. Saving Run	Closed: Energy-saving				
64	Search 3	O/P Freq. Sp_Search	Closed: Speed search from output frequency Open: Base Block				
65	Integral valve reset at PID control	Integral Reset	Closed: Integral value reset at PID control				
66	PID control cancel	PID Invalid	Closed: PID control canceled				
67 to FF	Not used	Reserved	-	-	-	-	-

Setting error "I/P Freq. Incorrect (OPE3) Alarm" occurs by setting to Sn-15 to -18 in the following cases.

- When set values are not listed from smaller to the larger.
- When more than two search references of set values 61, 62 and 64 are set simultaneously.

When the following combination is set at Sn-15 to -18, set value fault "I/P Freq. Incorrect (OPE3) Alarm" occurs.

1. Set values are not in descending order.
2. More than two search commands of set values 61 and 62 are set.
3. UP/DOWN commands are not set simultaneously. (only one command can be set)
4. UP/DOWN and accel/decel prohibit commands are set simultaneously.
5. More than two set values except FF are set.

(1) FWD/REV run selection (set value = 0)

When 0 is set in Sn-15, the mode becomes 3-wire sequence mode.

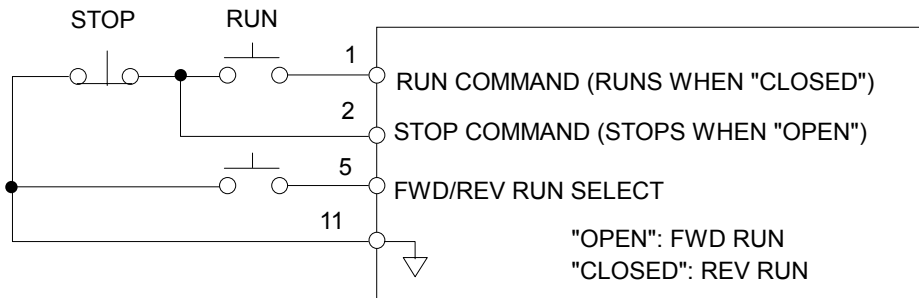

(2) Operation signal selection (set value = 1)

Selection of operation signals is enabled only while the inverter is not running.

Open: The inverter operates according to the setting of 1st, 2nd digits.

Closed: The inverter operates by frequency reference and run command from the digital operator.

< Example >

For local/remote mode selection, set Sn-04 = x x 00.

Open: Frequency reference and run command from control circuit terminals are accepted.

Closed: Frequency reference and run command from the digital operator is accepted.

(3) Option card/inverter reference selection (set value = 2)

Specify which of the option cards or inverter references is used for operation. The option card/inverter selection is effective only while the inverter is not running.

Open: Option card frequency reference and operation signals are accepted.

Closed: Frequency reference and operation signals from the inverter control circuit terminals or the digital operator are accepted.

(4) Selection of multi-step speed references 1 to 3 and jogging frequency selection (set values = 3 to 6)

Up to nine step speeds can be selected by combinations of multi-step speed references and jog frequencies.

: Closed ×: Open -: No relation

Jog Frequency Reference Selection	Multi-Step Reference			Frequency Reference
	3	2	1	
×	×	×	×	Master speed frequency reference*
×	×	×		Auxiliary analog reference
×	×		×	Frequency reference 3 (An-03)
×	×			Frequency reference 4 (An-04)
×		×	×	Frequency reference 5 (An-05)
×		×		Frequency reference 6 (An-06)
×			×	Frequency reference 7 (An-07)
×				Frequency reference 8 (An-08)
	-	-	-	Jog frequency (An-09)

* In operator mode (1st digit of Sn-04 is 1), frequency reference 1 (An-01) is enabled.

+ When the multi-function analog input is selected by functions other the frequency reference (Sn-19 = 0), frequency reference 2 (An-02) becomes effective. When the multi-function analog input is not used, set F to the set value.

- For multi-step speed operation with frequency reference from digital operator, perform the following setting:

- 1 Sn-04 = xxx1 An-01 becomes effective.
- 2 Sn-19 00 An-02 becomes effective.

(5) Accel/decel time selection (select value = 7)

Accel/decel time is switched when "closed". Switching is permitted even during acceleration or deceleration.

Open: The accel/decel time set by bn-01 and bn-02 is accepted.

Closed: The accel/decel time set by bn-03 and bn-04 is accepted.

(6) External baseblock (set value = 8)

Baseblock is performed when "closed". External baseblock differs as follows depending on the input status of the run command:

- When an external baseblock signal is input during running, $\overline{b} \overline{b}$ blinks on the digital operator and inverter output is shut OFF. When the external baseblock signal disappears, the inverter restarts with the frequency reference at that time. The voltage returns to the set value in the voltage recovery time.
- When a stop signal is input and an external baseblock signal is input while the inverter is decelerating, "B.B. (bb) Alarm" blinks on the digital operator, the inverter output is shut OFF, and the output frequency is set to 0Hz.

(7) External baseblock (set value =9)

Baseblock is performed when "open". All other operations are the same as when set value = 8.

(8) Accel/decel speed prohibit command (set value = A)

As long as accel/decel speed prohibit command is input, accel/decel speed is prohibited and the output frequency at that time is held. When stop command is input, accel/decel speed prohibit state is freed and the system enters stop state. The figure below shows a time chart.

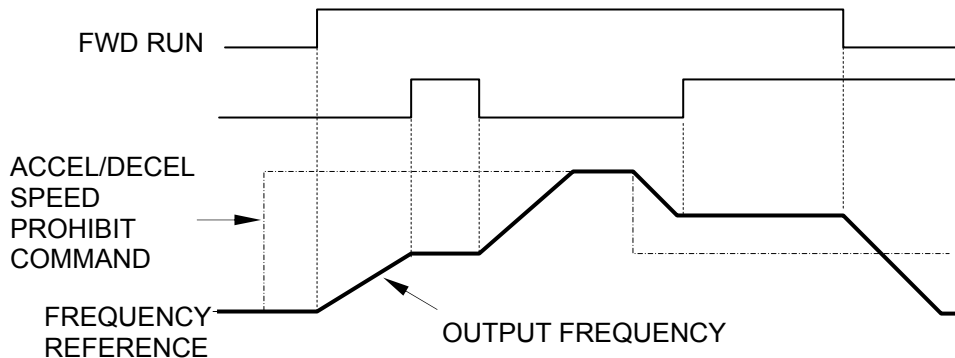

Note: If the run command is input again after the stop command is input while the accel/decel prohibit command is input, the holding output frequency is stored unless the accel/decel prohibit command is released. Therefore, operation is performed at the stored output frequency. Also when the power supply is turned OFF in the accel/decel prohibit command input status, the holding output frequency is still stored.

(9) Inverter overheat alarm (set value = B)

As long as an inverter overheat signal is input, "Over Heat (OH2) Alarm" blinks on the digital operator.

(10) Auxiliary analog reference input (set value = C)

When this function is selected by the multi-function terminal, the function set in the multi-function analog input is subject to the following restrictions.

Open: Multi-function analog input is not accepted.
(Same operation as when F is set in Sn-19)

Closed: Multi-function analog input is accepted.

(11) No Speed Control (set value = D)

To use or not use speed control can be switched over during operation. When the contact for the speed control is closed, no speed control is available. Integral value in speed control is held until the operation stops.

Open: Speed control provided (closed loop)

Closed: Speed control not provided (open loop)

(12)Integral Value Reset in Speed Control (set value = E)

Integral value in speed control can be reset during operation.

Open: PI control (Integral value in speed control is added).

Closed: P control (Integral value in speed control is reset at time constant of accel/decel time to be selected).

(13)UP command/DOWN command (set value = 10, 11)

Acceleration/deceleration is performed by inputting the UP/DOWN commands without changing frequency reference in the forward (reverse) run command input status and operation can be performed at a desired speed.

Set value = 10: UP command

Set value = 11: DOWN command

UP command	Closed	Open	Open	Closed
DOWN command	Open	Closed	Open	Closed
Status	Accel	Decel	Hold	Hold

The following time chart indicates when the UP/DOWN commands are used.

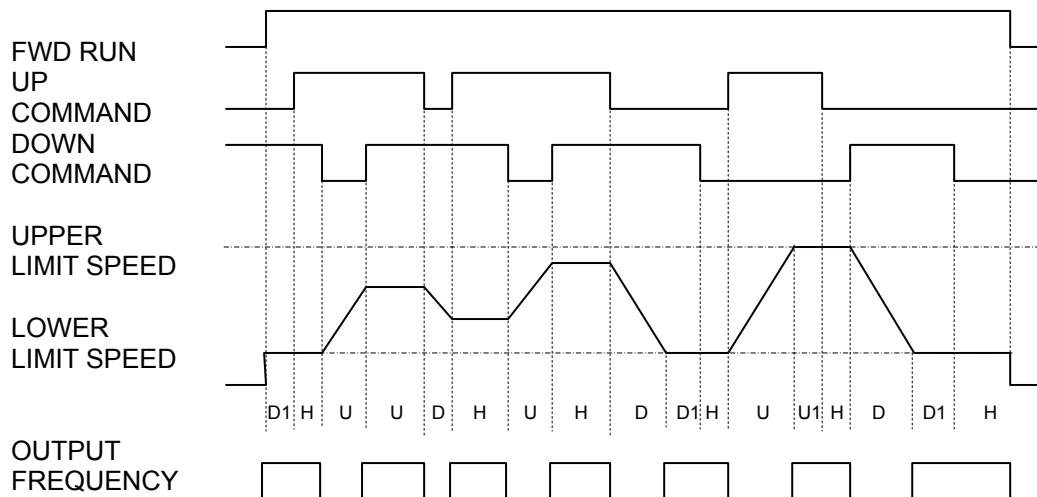

- U= UP (accel) status
- D= DOWN (decel) status
- H= HOLD (constant speed) status
- U1= During clamp at upper limit speed even in UP status
- D1= During clamp at lower limit speed even in DOWN status

Notes:

1. When the UP/DOWN commands are used, set Sn-04 1st digit and 2nd digit to 0, if not equal to 0, UP/DOWN commands are disable.
2. When the UP/DOWN commands are selected, upper limit speed is set disregarding frequency reference.

$$\text{Upper limit speed} = \text{max. output freq. (Cn-02)} \times \text{freq. reference lower limit (Cn-14)}$$

3. The largest value among minimum output frequency (Cn-07), frequency reference lower limit (Cn-15) and main frequency reference input from control circuit terminal 13 or 14 is employed as lower limit speed.

When output frequency lower than Cn-07, the inverter with no output. The minimum of frequency command depend on the value of Cn-15 and Cn-07. Besides, the inverter output when $Cn-15 > Cn-07$.

4. By inputting the FWD/REV run commands, operation is started at the lower limit speed even if the UP/DOWN command is not input.

When the power supply is turned OFF in the HOLD status, the held output frequency is stored. By inputting the FWD/REV run commands in the HOLD status continuously after the power supply is turned ON, operation is performed at the stored output frequency.

5. When the JOG run command is input during running by UP/DOWN commands, the JOG run command has priority.

(14)FJOG command, RJOG command (set value = 12, 13)

Forward and reverse jog frequency operation is enabled.

Set value = 12 FJOG command: Forward run by jog frequency reference (An-09) at closed.

Set value = 13 RJOG command: Reverse run by jog frequency reference (An-09) at closed.

Notes:

1. When FJOG command or RJOG command is input during running, FJOG command or RJOG command has priority.
2. When both FJOG and RJOG commands are closed for 500ms or more, the inverter stops according to the stopping method selection (Sn-04).
3. FJOG or RJOG command can be set individually.

(15) External faults 1 to 4 (set values = 2X, 3X, 4X, 5X: X is 0 to F)

When external faults 1 to 4 are input, “External Fault 3 (EF3)” to “External Fault 8 (EF8)” is displayed on the digital operator, and the inverter operates according to combinations of four bits shown in the table below. The hexadecimal equivalent of combinations of four bits shown below is set in the 1st digit of the setting value (2X, 3X, 4X, 5X) of external faults 1 to 4.

Bit No.	0	1
0	External fault input: NO - contact input	External fault input: NC - contact input
1	External fault signal: Always detected	External fault signal: Detected during running only
3,2	Selection of processing at external fault detection	00: Ramp to stop (major fault) 01: Coast to stop (major fault) 10: Ramp to stop by bn-04 (major fault) 11: Operation to continue (minor fault)

<Example> External fault 1 is set as follows.
 : NO - contact input
 : Signal is always detected
 : Processing is coast to stop

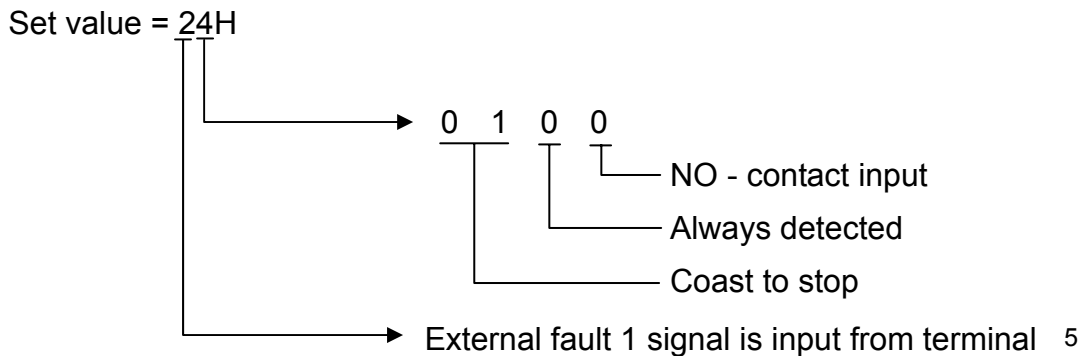

The inverter operates differently as described below when experiencing major faults or minor faults. The digits in the error display “External Fault 3 (EF3)” to “External Fault 8 (EF8)” indicate the terminal numbers in which external faults 1 to 4 are set.

Major faults

If an external fault is input, the fault is displayed and the inverter stops according to process selection at external fault detection. Fault contact output relay is output immediately.

Minor faults

Fault display blinks only when external fault is input (the display is made for 0.5 second even when input is less than 0.5 second).

<Example> External faults 1 to 4 are set to multi-function terminals 1 to 4.
(Nos. of terminal 5 to 8)

No. of Fault	Multi-function Terminal	Display on Digital Operator	
		(Major Fault) - Light	(Minor Fault) - Blinking
External Fault 5	Terminal 5	Ext. Fault 5 (EF5) Fault	Ext. Fault 5 (EF5) Alarm
External Fault 6	Terminal 6	Ext. Fault 6 (EF6) Fault	Ext. Fault 6 (EF6) Alarm
External Fault 7	Terminal 7	Ext. Fault 7 (EF7) Fault	Ext. Fault 7 (EF7) Alarm
External Fault 8	Terminal 8	Ext. Fault 8 (EF8) Fault	Ext. Fault 8 (EF8) Alarm

Additional Notes of External Faults:

1. External fault reset is enabled in baseblock status.
2. The following shows the priority order of process selection when more than one external fault is input.
Coast to stop > ramp to stop by bn-04 > ramp to stop by bn-02.
3. Fault retry is disabled when an external fault is input.

(16)DC injection braking command (set value = 60)

When DC braking command is input when the inverter stops, DC braking operation is performed. When operation signal or jog operation command is input, the DC braking operation is stopped and the operation is started. (Privileged operation)

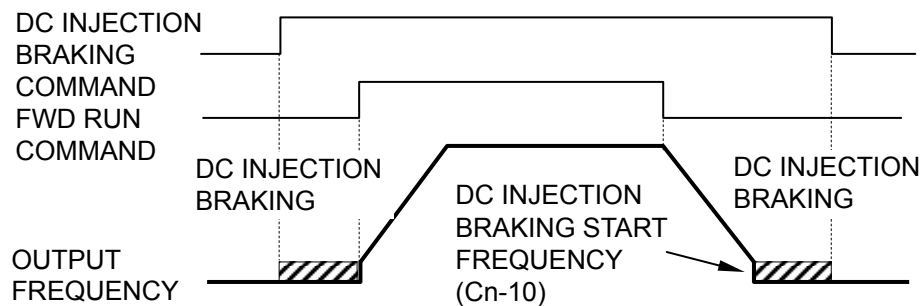

(17) Search command (set value = 61,62)

To start the motor during coasting when commercial power supply/inverter changing operation is performed, the motor can be operated without tripping by using the speed search function.

Set value = 61: Speed search starts with the maximum frequency.

Set value = 62: Speed search starts with the frequency reference value when search command is input.

Search commands with set values of 61 and 62 cannot be set at the same time.

By inputting the run command with the search command "closed" during baseblock, speed search starts after shutting down the inverter output for the minimum baseblock time (Cn-40).

Speed search operation starts when inverter output current is larger than the set value of the speed search operation level (Cn-38). The frequency at which inverter output current is smaller is determined as the speed synchronous point: Re-acceleration/deceleration is performed in the set accel/decel time up to the set frequency.

The following shows the time chart where the speed search command is input.

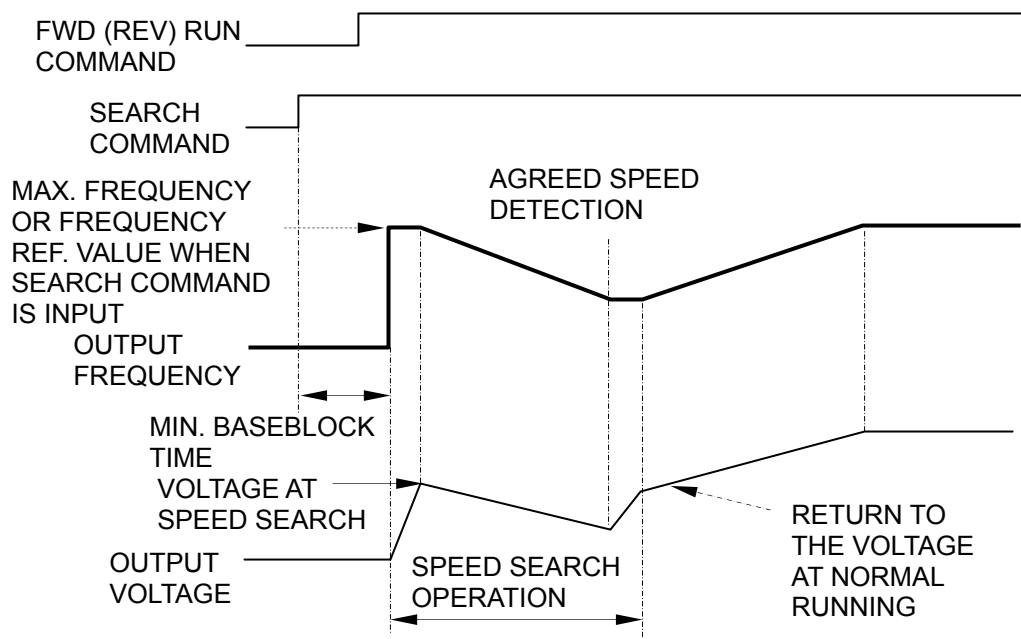

Notes:

1. In momentary power loss operation continuation mode, speed search operation is performed beginning with current output frequency, regardless of the existence of search command. After completion of speed search, the operation is performed according to the run command.

2. Determine a sequence so that FWD/REV run command enters at the same time or later than search command.

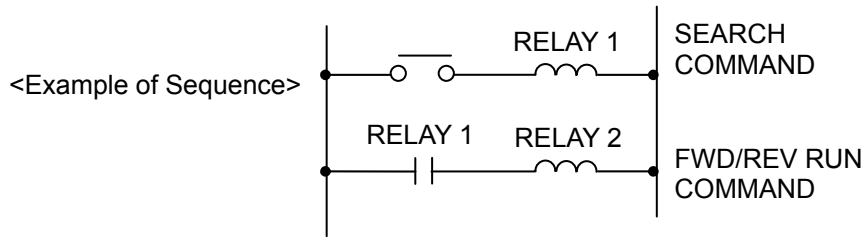

3. More than two search commands for set values of 61 and 62 cannot be set.

(18)Energy-saving operation command (set value = 63)

When energy-saving operation command is input, output voltage is reduced only during agreed frequency and energy-saving operation is performed. The output voltage during energy-saving operation command is the product of normal V/F (Cn-02 to Cn-08) and energy-saving gain (bn-09 initial value 80%). Output voltage attenuates and returns in voltage recovery time.

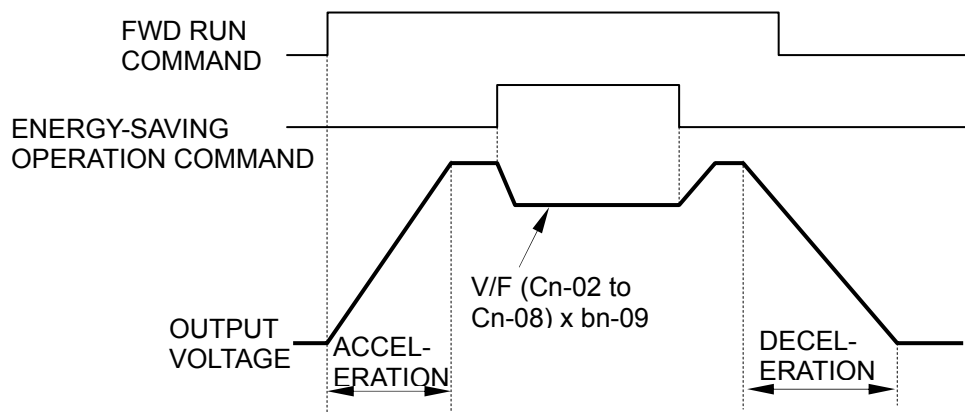

Time Chart - When energy-saving operation command is input

(19)Search command 3 (set value = 64)

Special application for power regeneration converter momentary power loss.

(20)Integral value reset (set value = 65)

Value I is reset to 0 when an integral value reset command is input from multifunction contact input (terminal 5~8, set 65 either to Sn-15 to 18). Refer to Appendix C.

(21)PID control cancel (set value = 66)

PID control circuit can be canceled by multifunction contact input signal. Set 66 either to Sn-15 to 18 and close the contact (either terminal 5 to 8) during running. Then the PID control circuit is canceled and the aimed value signal is used as a frequency reference signal without being changed. In this case, the signal input level is 0 the 10V (or 4 to 20mA)/0 to 100%. Refer to Appendix C.

■ Multi-Function Analog Input Selection **Sn-19**

Parameter No.	Name	LCD Display (English)	Description	Factory Setting	Change During Operation	Valid Access Levels			
						GP	SL	PID	PG
Sn-19	Multi-function analog input (Terminal 16)	Sn-19=00 Multi-Fct $\sqrt{\quad}$ Input	00~0B Selects terminal 16 function (factory preset for auxiliary frequency command)	00					

Select the set values shown below for Sn-19.

Set value	Function	LCD Display (English)	Description	Valid Access Levels			
				GP	SL	PID	PG
00	AUX frequency reference*1	Auxiliary Freq. Cmd	Used for MASTER/AUX frequency reference selection.				
01	Frequency reference gain (F GAIN)	$\sqrt{\quad}$ Freq. Cmd Gain	Total gain: Internal gain (bn-05) x F GAIN				
02	Frequency reference bias 1 (F BIAS 1)	Cmd. Bias 1	Total bias: Internal bias (bn-06) + F BIAS 1				
03	Frequency reference bias 2 (F BIAS 2)	Cmd. Bias 2	Total bias: Internal bias (bn-06) + F BIAS 2				
04	Overtorque detection level	Over Tq. Level	Internal overtorque detection level (Cn-26) ineffective.				
05	V BIAS*2	V/F curve Cmd. Bias	V BIAS addition after V/F conversion.				
06	Accel/decel time reduction coefficient	Acc. & Dec. coeff.	Accel/decel time varied by analog input.				
07	DC braking current	DC Braking current	DC injection braking current varied by analog input. (10V/inverter rated current) Internal DC braking current setting (Cn-11) ineffective.				
08	Stall level during running	Run stall Level	Stall level during running is set by analog input. Cn-30 becomes ineffective.				
09	Frequency reference lower limit (PID Control selection)*3	Freq. Cmd. Low Bound (PID Command)*3	Frequency reference lower limit value is set by analog input. Either Cn-15 set value or analog input whichever is larger becomes effective. (PID Control performed)*3			*3	
0A	Setting prohibit frequency 4 (Frequency reference lower limit)*4	Freq. Jump 4 (Freq. Cmd. Low Bound)*4	Setting prohibit frequency is set. The fourth value in addition to frequency values set by Cn-16 to 18 can be set.			*4	
0B	Setting prohibit frequency 2 (Torque limit)*5	Freq. Jump 2 (Torque limit)*5	Set prohibit freq. 2 (The 2nd value in addition to frequency value set by Cn-16 can be set) (Torque limit 10V/250%)*5		*5		
0C to 0F	Not used	Reserved	-	-	-	-	-

*1. Not to be used with An-02.

*2. 440 class: V BIAS value 0 to 200V

*3. Function as PID control selection in the PID control mode (PID).

*4. Function as frequency reference low limit in the PID control mode (PID).

*5. Function as torque limit to the motor output torque in the sensorless vector control mode (SL).

Multi-function Analog Input Characteristics

<p>(1) Sn-19 = 0</p>	<p>(2) Sn-19 = 1</p>
<p>(3) Sn-19 = 2</p>	<p>(4) Sn-19 = 3</p>
<p>(5) Sn-19 = 4</p>	<p>(6) Sn-19 = 5</p>
<p>(7) Sn-19 = 6</p> <p>Actual accel/decel time = $\frac{\text{Accel/decel time (bn-01~04)}}{\text{Reduction coefficient}}$</p>	<p>(8) Sn-19 = 7</p>
<p>(9) Sn-19 = 08</p>	<p>(10) Sn-19 = 09</p>
<p>(11) Sn-19 = 0A</p>	<p>(12) Sn-19 = 0B (at SL mode)</p>

■ Multi-Function Contact Output Selection **Sn-20 to -22**

Parameter No.	Name	LCD Display (English)	Description	Factory Setting	Change During Operation	Valid Access Levels			
						GP	SL	PID	PG
Sn-20	Multi-function contact output (Terminal 9 - 10)	Sn-20=00 Term. 9 Function	00~0E Selects terminal 9 - 10 function (factory preset for running)	00					
Sn-21	Multi-function PHC output (Terminal 25 - 27)	Sn-21=01 Term. 25 Function	00~0E Selects terminal 25 - 27 function (factory preset for zero speed)	01					
Sn-22	Multi-function PHC output (Terminal 26 - 27)	Sn-22=02 Term. 26 Function	00~0E Selects terminal 26 - 27 function (factory preset for Agreed frequency)	02					

- Select the set values shown below for Sn-20 to -22. Contact output for 0.1 sec. while detecting signal.

Set value	Function	LCD Display (English)	Description	Valid Access Levels			
				GP	SL	PID	PG
00	During running	Running	Closed: During running				
01	Zero speed	Zero speed	Closed: Zero speed				
02	Agreed frequency	Frequency Arrive	Closed: $\left[\begin{array}{l} \text{Frequency ref.} \\ -\text{Cn-22} \end{array} \right]$ Output frequency $\left[\begin{array}{l} \text{Frequency ref.} \\ +\text{Cn-22} \end{array} \right]$				
03	Agreed frequency setting	Agreed F Arrive	Closed: Set value 2 in agreed frequency status and (Cn-21-Cn-22) output frequency (Cn-21 +Cn-22)				
04	Frequency detection 1	Freq. Det. 1	Closed: Output frequency Cn-21				
05	Frequency detection 2	Freq. Det. 2	Closed: Output frequency Cn-21				
06	Inverter operation ready	Run Ready OK!	Closed: Inverter operation ready				
07	During undervoltage detection	Low Volt Detect	Closed: During undervoltage detection				
08	During baseblock	Output B.B.	Closed: During inverter output baseblock				
09	Frequency reference mode	Freq. Cmd. Operator	Open: From control circuit terminal Closed: From operator				
0A	Control command	Run Source Operator	Open: From control circuit terminal Closed: From operator				
0B	Overtorque detection	Over Tq. Detect	Closed: During overtorque reference missing				
0C	Frequency reference missing	Freq. Cmd. Missing	Closed: While frequency reference missing				
0D	Not used	Reserved	-	-	-	-	-
0E	Fault	Fault	Closed: Fault (except CPF 00, CPF 01)				
0F	Not used	Reserved	-	-	-	-	-

(1) Operation (set value = 0)

The operation contact is "closed" when FWD or REV run command is input, or the inverter outputs voltage.

(2) Zero-speed (set value = 1)

The zero-speed contact is "closed" when inverter output frequency is less than the minimum output frequency.

(3) Agreed frequency (set value = 2)

This is "closed" when output frequency is within the detection width shown in the figure below.

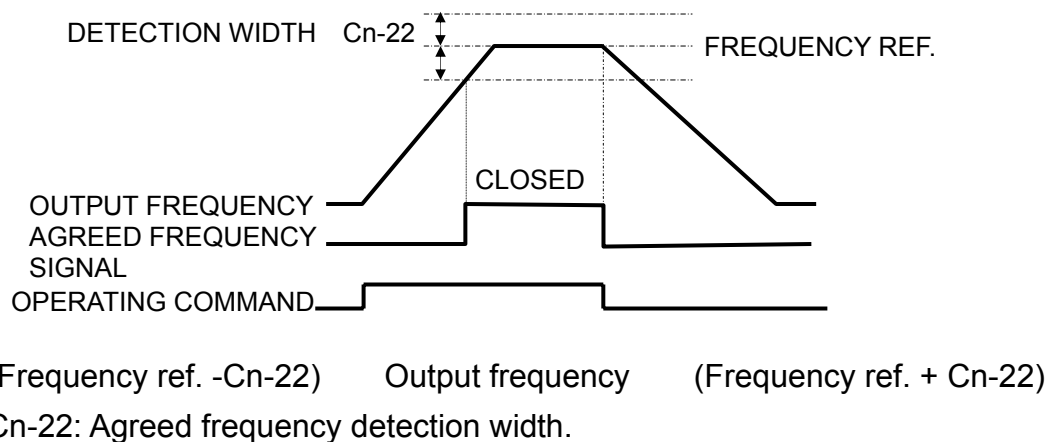

(4) Agreed frequency (Set value = 3)

This is "closed" when acceleration or deceleration is completed and output frequency is within the detection width shown in the figure below.

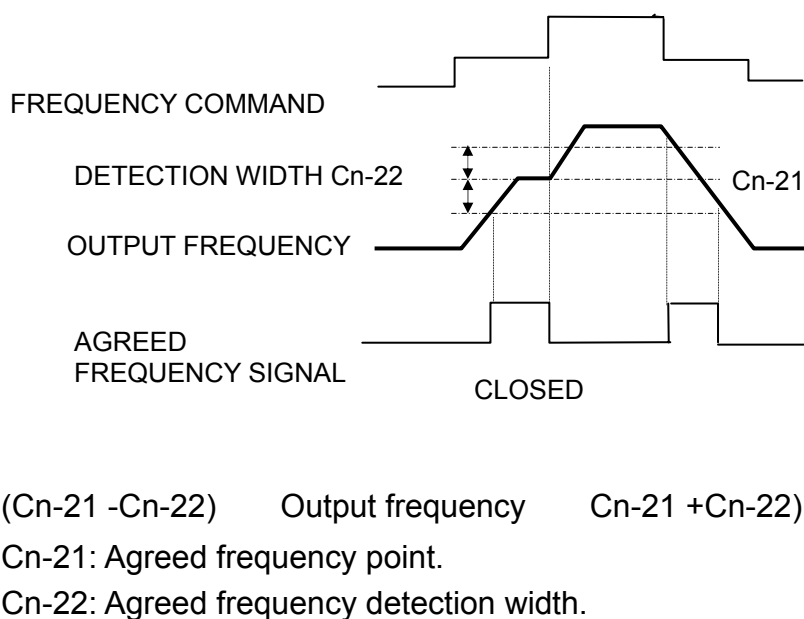

(5) Frequency detection (set value = 4)

This contact is "closed" when output frequency is equal to or less than Cn-21, as shown in the figure below.

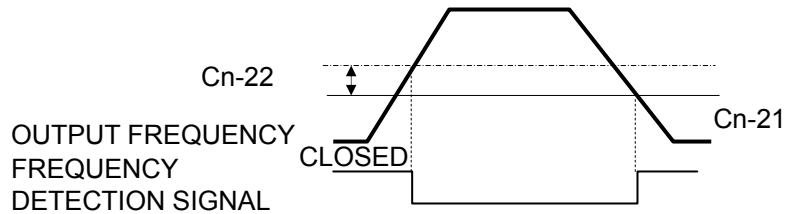

Output frequency Cn-21

Cn-21: Agreed frequency point.

Cn-22: Agreed frequency detection width.

(6) Frequency detection (set value = 5)

This contact is "closed" when output frequency is equal to or greater than Cn-21, as shown in the figure below.

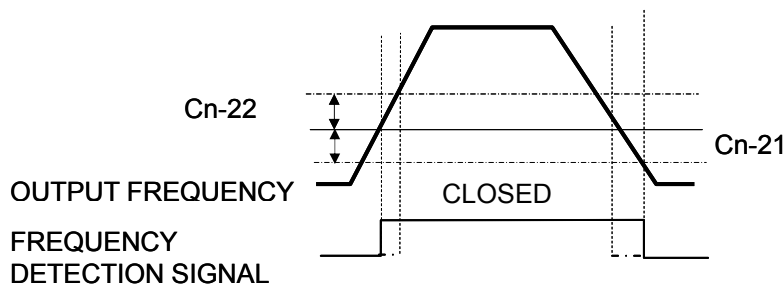

Output frequency Cn-21

Cn-21: Agreed frequency point.

Cn-22: Agreed frequency detection width.

(7) Inverter operation ready (set value = 6)

This is "closed" when the inverter has become ready for operation.

(8) During undervoltage (UV) detection (set value = 7)

This contact remains "closed" as long as the inverter is detecting undervoltage.

(9) During baseblock (set value = 8)

This contact is always "closed" when inverter output is shut OFF.

(10) Frequency reference mode (set value = 9)

This contact is "closed" when the frequency reference mode from the operator is selected.

(11) Control command (set value = A)

This contact is "closed" when the control command from the keyboard is selected.

(12) Overtorque detection (set value = B)

This contact remains "closed" as long as the inverter is detecting overtorque. Set overtorque detection level in Cn-26 and set overtorque detection time in Cn-27.

(13) Frequency reference missing (set value = C)

This is "closed" when frequency reference missing is detected.

(14) Not used (set value = D)

Multi-function contact output not used.

(15) Fault (set value = E)

This contact is "closed" when the inverter detects a major fault. However, in the event of a fault in the watchdog (CPF00) or transmission between the mainframe and operator, the inverter is not operated.

(16) Not used (set value = F)

Multi-function contact output not used.

■ **LCD Language Selection** **Sn-23**

Parameter No.	Name	LCD Display (English)	Description	Factory Setting	Change During Operation	Valid Access Levels			
						GP	SL	PID	PG
Sn-23	LCD Language displayed selection	Sn-23=0 Language: English	0: English 1: Chinese						

■ Option Card Function Selection **Sn-25 to Sn-28**

Parameter No.	Name	LCD Display (English)	Description	Factory Setting	Change During Operation	Valid Access Levels			
						GP	SL	PID	PG
Sn-25 ~ Sn-28	*	*	*	*		1	2	3	4

* Differs according to control mode.

1. GP

Function	Sn-	Name	LCD Display	Descriptions				Factory Setting		
				4th digit	3rd digit	2nd digit	1st digit			
Option Card Function Selection	Sn-25	Analog Reference Card (AI-14B)	Sn-25=0000 AI-14B Fun. Select	-	-	-	0	Positive/negative values of frequency reeference determine FWD/REV operation	0000	
				-	-	-	1	Positive frequency reference value determine forward operation Chegative=0 output		
		-		-	-	-	Not used			
	Sn-26	Digital Reference Card (DI-08) Ferquency reference set mode	Sn-26=0000 DI-08 Fun. Select	0	0	0	0	BCD input 1% resolution	0000	
				0	0	0	1	BCD input 0.1% resolution		
				0	0	1	0	BCD input 0.01% resolution		
				0	0	1	1	BCD input 1Hz resolution		
				0	1	0	0	BCD input 0.1Hz resolution		
				0	1	0	1	BCD input 0.01Hz resolution		
				1	0	1	1	BINARY input 255/100%		
	Sn-27	Digital Output Card (DO-08)	Sn-27=0010 DO-08 & PM-C	-	-	-	0	Selects item 1 to be output from DO-08	0010	
				-	-	-	1	Selects item 21 to be output from DO-08		
		Digital pulse Monitor Card (PM-C)		0	0	0	-	1F (F: output frequency)		
				0	0	1	-	6F (F: output frequency)		
				0	1	0	-	10F (F: output frequency)		
				0	1	1	-	12F (F: output frequency)		
				1	0	0	-	36F (F: output frequency)		
	Sn-28	Analog Monitor Card (AO-12)	Sn-28=0100 AO-12 Fun. Select	-	-	0	0	Output frequency (max. frequency/100%)	Channd 1	0100
				-	-	0	1	Output current (Rated current/100%)		
				-	-	1	0	Output voltage (Cn-01/100%)		
				-	-	1	1	DC voltage (220V: 400V/100%, 440V: 800V/100%)		
				Channd 2	0	0	-	-	Output frequency (max. frequency/100%)	
					0	1	-	-	Output current (Rated current/100%)	
					1	0	-	-	Output voltage (Cn-01/100%)	
1					1	-	-	DC voltage (220V: 400V/100%, 440V: 800V/100%)		

2. SL

Function	Sn-	Name	LCD Display	Descriptions				Factory Setting		
				4th digit	3rd digit	2nd digit	1st digit			
Option Card Function Selection	Sn-25	Analog Reference Card (AI-14B)	Sn-25=0000 AI-14B Fun. Select	-	-	-	0	Positive/negative values of frequency reeference determine FWD/REV operation	0000	
				-	-	-	1			Positive frequency reference value determine forward operation Chegative=0 output
		-		0	0	0	-	Not used		
	Sn-26	Digital Reference Card (DI-08) Ferquency reference set mode	Sn-26=0000 DI-08 Fun. Select	0	0	0	0	BCD input 1% resolution	0000	
				0	0	0	1	BCD input 0.1% resolution		
				0	0	1	0	BCD input 0.01% resolution		
				0	0	1	1	BCD input 1Hz resolution		
				0	1	0	0	BCD input 0.1Hz resolution		
				0	1	0	1	BCD input 0.01Hz resolution		
				0	1	1	1	BINARY input 255/100%		
	Sn-27	Digital Output Card (DO-08)	Sn-27=0010 DO-08/ Fun. Select	-	-	-	0	Selects item 1 to be output from DO-08	0010	
		-		-	-	1	Selects item 21 to be output from DO-08			
		Digital pulse Monitor Card (PM-C)		0	0	0	-	Not used		
				0	0	1	-	Not used		
				0	1	0	-	Not used		
				0	1	1	-	Not used		
				1	0	0	-	Not used		
	Sn-28	Analog Monitor Card (AO-12)	Sn-28=0100 AO-12 Fun. Select	-	-	0	0	Output frequency (max. frequency/100%)	Channel 1	0100
				-	-	0	1	Output current (Rated current/100%)		
				-	-	1	0	Output voltage (Cn-01/100%)		
				-	-	1	1	DC voltage (220V: 400V/100%, 440V: 800V/100%)		
				0	0	-	-	Output frequency (max. frequency/100%)	Channel 2	
				0	1	-	-	Output current (Rated current/100%)		
				1	0	-	-	Torque monitor (motor rated torque/100)		
				1	1	-	-	Output power (motor rated power/100%)		

3. PID

Function	Sn-	Name	LCD Display	Descriptions				Factory Setting		
				4th digit	3rd digit	2nd digit	1st digit			
Option Card Function Selection	Sn-25	Analog Reference Card (AI-14B)	Sn-25=0000 AI-14B Fun. Select	-	-	-	0	Positive/negative values of frequency reeference determine FWD/REV operation	0000	
				-	-	-	1	Positive frequency reference value determine forward operation Chegative=0 output		
		-		0	0	0	-	Not used		
	Sn-26	Digital Reference Card (DI-08) Ferquency reference set mode	Sn-26=0000 DI-08 Fun. Select	0	0	0	0	BCD input 1% resolution	0000	
				0	0	0	1	BCD input 0.1% resolution		
				0	0	1	0	BCD input 0.01% resolution		
				0	0	1	1	BCD input 1Hz resolution		
				0	1	0	0	BCD input 0.1Hz resolution		
				0	1	0	1	BCD input 0.01Hz resolution		
				0	1	1	1	BINARY input 255/100%		
	Sn-27	Digital pulse Monitor Card (PM-C)	Sn-27=0010 PM-C Fun. Select	-	-	-	0	Not used	0010	
				-	-	-	1	Not used		
				0	0	0	-	1F (F: output frequency)		
				0	0	1	-	6F (F: output frequency)		
				0	1	0	-	10F (F: output frequency)		
				0	1	1	-	12F (F: output frequency)		
				1	0	0	-	36F (F: output frequency)		
	Sn-28	Analog Monitor Card (AO-12)	Sn-28=0100 AO-12 Fun. Select	-	-	0	0	Output frequency (max. frequency/100%)	Channd 1	0100
				-	-	0	1	Output current (Rated current/100%)		
				-	-	1	0	Output voltage (Cn-01/100%)		
				-	-	1	1	DC voltage (220V: 400V/100%, 440V: 800V/100%)		
				0	0	-	-	Output frequency (max. frequency/100%)	Channd 2	
				0	1	-	-	Output current (Rated current/100%)		
				1	0	-	-	Output voltage (Cn-01/100%)		
				1	1	-	-	DC voltage (220V: 400V/100%, 440V: 800V/100%)		

4. PG

Function	Sn-	Name	LCD Display	Descriptions				Factory Setting			
				4th digit	3rd digit	2nd digit	1st digit				
Option Card Function Selection	Sn-25	Analog Reference Card (AI-14B)	Sn-25=0000 AI-14B Fun. Select	-	-	-	0	Positive/negative values of frequency reeference determine FWD/REV operation	0000		
				-	-	-	1	Positive frequency reference value determine forward operation Chegative=0 output			
		-		-	-	-	0	0		0	-
	Sn-26	-	-	Sn-26=0000 Reserved	-	-	-	-	Not used	0000	
					-	-	-	-	Not used		
					-	-	-	-	Not used		
					-	-	-	-	Not used		
					-	-	-	-	Not used		
					-	-	-	-	Not used		
					-	-	-	-	Not used		
	Sn-27	PG Speed Control Card (FB-C) Function Selection 1	-	Sn-27=0100 FB-C Function 1	-	-	-	0	Speed control provided	0100	
					-	-	-	1	Speed control not provided		
					-	-	0	-	Inteqral control during accel/decel provided		
					-	-	1	-	Inteqral control during accel/decel not provided		
					0	0	-	-	Processing at PG Line Baker		Ramp to a stop (decel time 1: bn-02)
					0	1	-	-			Coasting to a stop
					1	0	-	-			Ramp to a stop (decel time 2: bn-04)
					1	1	-	-			Operation to continne
	Sn-28	PG Speed Control Card (FB-C) Function Selection 2	-	Sn-28=0101 FB-C Function 2	-	-	0	0	Processing at Overspeed Detection	Ramp to a stop (decel time 1: bn-02)	0101
					-	-	0	1		Coasting to a stop	
					-	-	1	0		Ramp to a stop (decel time 2: bn-04)	
					-	-	1	1		Operation to continne	
					0	0	-	-	Processing at Excessive Speed Deviation	Ramp to a stop (decel time 1: bn-02)	
					0	1	-	-		Coasting to a stop	
					1	0	-	-		Ramp to a stop (decel time 2: bn-04)	
					1	1	-	-		Operation to continne	

■ Motor Parameters Auto tuning Selection **Sn-29**

Parameter No.	Name	LCD Display (English)	Description	Factory Setting	Change During Operation	Valid Access Levels			
						GP	SL	PID	PG
Sn-29	Motor parameters Auto tuning Selection	Sn-29=0 Motor Auto. Test	0: Autotuning invalid 1: Autotuning valid						

2.5 Control Parameters Cn-

Function	Parameter No.	Name	LCD Display (English)	Change During Operation	Setting Range	Setting Unit	Factory Setting	Valid Access Levels				Ref. Page
								GP	SL	PID	PG	
V/F Pattern Setting	Cn-01	Input Voltage	Cn-01=220.0V Input Voltage		150~255.0V* ¹	0.1V	220.0V* ²					
	Cn-02	Max. Output Frequency	Cn-02=060.0Hz Max. O/P Freq.		50.0~400.0Hz	0.1Hz	60.0Hz					
	Cn-03	Max. Output Voltage	Cn-03=220.0V Max. Voltage		0.1~255.0V* ¹	0.1V	220.0V* ²					
	Cn-04	Max. Voltage Frequency	Cn-04=060.0Hz Max. Volt Frequency		0.1~400.0Hz	0.1Hz	60.0Hz					
	Cn-05	Middle Output Frequency	Cn-05=003.0Hz Middle O/P Freq.		0.1~400.0Hz	0.1Hz	3.0Hz					
	Cn-06	Voltage At Middle Output Frequency	Cn-06=016.5V Middle Voltage		0.1~255.0V* ¹	0.1V	16.5V* ¹	1	2		1	
	Cn-07	Min Output Frequency	Cn-07=001.5Hz Min O/P Freq.		0.1~400.0Hz	0.1Hz	1.5Hz	1	2	1	1	
	Cn-08	Voltage At Min. Output Frequency	Cn-08=011.0V Min. Voltage		0.1~255.0V* ²	0.1V	11.0V* ¹	1	2	3	1	
	Cn-09	Motor Rated Current	Cn-09=031.0A Motor Rated I		* 3	0.1A	31A* ⁴					
DC Braking Function	Cn-10	DC Injection Braking Starting Frequency	Cn-10=01.5Hz DC Braking Start F		0.1~10.0Hz	0.1Hz	1.5Hz					
	Cn-11	DC Braking Current	Cn-11=050% DC Braking Current		0~100%	1%	50%					
	Cn-12	DC Injection Braking Time At Stop	Cn-12=00.0s DC Braking Stop Time		0.0~25.5s	0.1s	0.5s	1	1	2	1	
	Cn-13	DC Injection Braking Time At Start	Cn-13=00.0s DC Braking Start Time		0.0~25.5s	0.1s	0.0s					
Frequency Limit	Cn-14	Frequency Command Upper Bound	Cn-14=100% Freq. Cmd. Up Bound		0~109%	1%	100%					
	Cn-15	Frequency Command Lower Bound	Cn-15=000% Freq. Cmd. Low Bound		0~109%	1%	0%					
Frequency Jump	Cn-16	Frequency Jump Point 1	Cn-16=000.0Hz Frequency Jump 1		0.0~400.0Hz	0.1Hz	0.0Hz					
	Cn-17	Frequency Jump Point 2	Cn-17=0.0Hz Frequency Jump 2		0.0~400.0Hz	0.1Hz	0.0Hz					
	Cn-18	Frequency Jump Point 3	Cn-18=0.0Hz Frequency Jump 3		0.0~400.0Hz	0.1Hz	0.0Hz					
	Cn-19	Jump Frequency Width	Cn-19=01.0Hz Freq. Jump Width		0.0~25.5Hz	0.1Hz	1.0Hz					
Display Unit	Cn-20	Digital Operator Display Unit	Cn-20=00000 Operator DSPL Unit		0~39999	1	0					
Agreed Speed Detection	Cn-21	Frequency Agree Detection Level	Cn-21=000.0Hz F Agree Det. Level		0.0~400.0Hz	0.1Hz	0.0Hz					
	Cn-22	Frequency Agree Detection Width	Cn-22=02.0Hz F Agree Det. Width		0.1~25.5Hz	0.1Hz	2.0Hz					
Carrier Frequency	Cn-23	Carrier Frequency Upper Limit	Cn-23=6.0KHz Carry-Freq. Up Bound		0.4~15.0KHz* ⁶	0.1KHz	6.0KHz* ⁶					
	Cn-24	Carrier Frequency Lower Limit	Cn-24=6.0KHz Carry-Freq. Low Bound		0.4~15.0KHz* ⁶	0.1KHz	6.0KHz* ⁶					
	Cn-25	Carrier Frequency proportion Gain	Cn-25=00 Carry-Freq. P_ Gain		0~99	1	0* ⁵					

Function	Parameter No.	Name	LCD Display (English)	Change During Operation	Setting Range	Setting Unit	Factory Setting	Valid Access Levels				Ref. Page
								GP	SL	PID	PG	
OVER-Torque Detection	Cn-26	Overtorque Detection Level	Cn-26=160% Over Tq. Det. Level		30~200%	1%	160%					
	Cn-27	Overtorque Detection Time	Cn-27=00.1s Over Tq. Det. Time		0.0~25.5s	0.1s	0.1s					
Stall Prevention	Cn-28	Stall Prevention Level During Acceleration	Cn-28=170% ACC. Stall		30~200%	1%	170%					
	Cn-29	Constant HP Area stall prevention	Cn-29=050% CH* ACC. Stall		30~200%	1%	50%					
	Cn-30	Stall Prevention Level During Running	Cn-30=160% Running Stall		30~200%	1%	160%					
Torque Boost Control	Cn-31	Motor Terminal Resistance	Cn-31=0.308Ω Motor Line R		0~65.535Ω	0.001Ω	0.308Ω* ⁴					
	Cn-32	Motor Iron Loss	Cn-32=425W Core Loss		0~65535W	1W	425W* ⁴	1	2	1	1	
	Cn-33	Torque Compensation Limiter	Cn-33=100V Tq. Comp. Limiter		0~50V* ¹	1V	100V* ⁴	1	2	1	1	
Simplified Speed Control	Cn-34	Motor No Load Current	Cn-34=030% Motor No_Load I		0~99%	1%	30%* ⁵					
	Cn-35	Slip Compensation Delay time	Cn-35=02.0s Slip Comp Time		0.0~25.5s	0.1s	2.0s	1	2			
Fault Retry	Cn-36	Number of Auto Reatart Attempt	Cn-36=00 Retry Times		0~10	1	0					
Ride-thru Time	Cn-37	Power Loss Ride-thru Time	Cn-37=2.0s Ride-thru Time		0~2.0s	0.1s	2.0s* ⁴					
Speed Search Control	Cn-38	Speed Search Detection Level	Cn-38=150% SP_Search Level		0~200%	1%	150%					
	Cn-39	Speed Search Time	Cn-39=02.0s SP_Search Time		0.1~25.5s	0.1s	2.0s					
	Cn-40	Min. Baseblock Time	Cn-40=1.0s Min. B.B. Time		0.5~5.0s	0.1s	1.0s* ⁴					
	Cn-41	V/F Curve in Speed Search	Cn-41=100% SP_Search V/F Curve		10~100%	1%	100%					
	Cn-42	Voltage Recovery Time	Cn-42=0.3s Voltage Recovery		0.1~5.0s	0.1s	0.3s					
PID, PG functions	Cn-43 ~ Cn-60	PID, PG function* ⁷								1	2	

*1 For 220V class. × 2 for 440V class.

*2 For 220V class. × 2 for 440V class.

*3 Setting range becomes 10 to 200% of inverter rated current.

*4 Factory settings differ depending on inverter capacity (Sn-01 set value).

This example shows combination of 440V 25HP (18.5KW) inverter and TECO standard motor 440V 4P 60Hz 25HP

*5 Motor rated current (Cn-09) becomes 100% level.

*6 Factory setting and setting range differ depending on inverter capacity (Sn-01 set value).

*7 Parameter for PID or PG Control mode. Refer to Appendix C and D.

■ V/F Pattern Selection **Cn-01 to Cn-08**

Parameter No.	Name	LCD Display (English)	Change During Operation	Setting Range	Setting Unit	Factory Setting	Valid Access Levels			
							GP	SL	PID	PG
Cn-01	Input Voltage	Cn-01=220.0V Input Voltage		150~255.0V* ¹	0.1V	220.0V* ²				
Cn-02	Max. Output Frequency	Cn-02=060.0Hz Max. O/P Freq.		50.0~400.0Hz	0.1Hz	60.0Hz				
Cn-03	Max. Output Voltage	Cn-03=220.0V Max. Voltage		0.1~255.0V* ¹	0.1V	220.0V* ²				
Cn-04	Max. Voltage Frequency	Cn-04=060.0Hz Max. Volt Frequency		0.1~400.0Hz	0.1Hz	60.0Hz				
Cn-05	Middle Output Frequency	Cn-05=003.0Hz Middle O/P Freq.		0.1~400.0Hz	0.1Hz	3.0Hz				
Cn-06	Voltage At Middle Output Frequency	Cn-06=016.5V Middle Voltage		0.1~255.0V* ¹	0.1V	16.5V* ¹	1	2		1
Cn-07	Min Output Frequency	Cn-07=001.5Hz Min O/P Freq.		0.1~400.0Hz	0.1Hz	1.5Hz	1	2	1	1
Cn-08	Voltage At Min. Output Frequency	Cn-08=011.0V Min. Voltage		0.1~255.0V* ²	0.1V	11.0V* ¹	1	2	3	1

(1) Input Voltage (Cn-01)

Parameter No.	Name	LCD Display (English)	Change During Operation	Setting Range	Setting Unit	Factory Setting	Valid Access Levels			
							GP	SL	PID	PG
Cn-01	Input Voltage	Cn-01=220.0V Input Voltage		150~255.0V* ¹	0.1V	220.0V* ²				

- Set inverter input voltage.
- When the set value of n-01 is larger than the motor rated voltage, the following problems may occur. (Set Cn-01 to match the motor rated voltage).
 - (a) The motor is excited excessively during deceleration and heated.
 - (b) The motor vibrates during deceleration.
 - (c) The motor is saturated during deceleration and the main circuit devices are damaged.
- The inverter change the operation levels according to the Cn-01 setting automatically as below shown.

Input Voltage (Cn-01)		LVH Signal	OV Level		BTR Level		UV Level	
Inverter	Set value		Detection	Return	Detection	Return	Detection	Return
220 Class	255 or less	L	400	380	380	375	210	220
440 Class	Set value 400	L	800	760	760	750	420	440
440 Class	Set value < 400	H	700	660	660	650	420	440

(2) Max. Output Frequency (Cn-02)

Parameter No.	Name	LCD Display (English)	Change During Operation	Setting Range	Setting Unit	Factory Setting	Valid Access Levels			
							GP	SL	PID	PG
Cn-02	Max. Output Frequency	Cn-02=060.0Hz Max. O/P Freq.		50.0~400.0Hz	0.1Hz	60.0Hz				

(3) Max. Output Voltage (Cn-03)

Parameter No.	Name	LCD Display (English)	Change During Operation	Setting Range	Setting Unit	Factory Setting	Valid Access Levels			
							GP	SL	PID	PG
Cn-03	Max. Output Voltage	Cn-03=220.0V Max. Voltage		0.1~255.0V*1	0.1V	220.0V*2				

(4) Max. Voltage Frequency (Cn-04)

Parameter No.	Name	LCD Display (English)	Change During Operation	Setting Range	Setting Unit	Factory Setting	Valid Access Levels			
							GP	SL	PID	PG
Cn-04	Max. Voltage Frequency	Cn-04=060.0Hz Max. Volt Frequency		0.1~400.0Hz	0.1Hz	60.0Hz				

(5) Middle Output Frequency (Cn-05)

Parameter No.	Name	LCD Display (English)	Change During Operation	Setting Range	Setting Unit	Factory Setting	Valid Access Levels			
							GP	SL	PID	PG
Cn-05	Middle Output Frequency	Cn-05=003.0Hz Middle O/P Freq.		0.1~400.0Hz	0.1Hz	3.0Hz				

(6) Voltage At Middle Output Frequency (Cn-06)

1. GP, PG

Parameter No.	Name	LCD Display (English)	Change During Operation	Setting Range	Setting Unit	Factory Setting	Valid Access Levels			
							GP	SL	PID	PG
Cn-06	Voltage At Middle Output Frequency	Cn-06=016.5V Middle Voltage		0.1~255.0V	0.1V	16.5V	1	2		1

2. SL

Parameter No.	Name	LCD Display (English)	Change During Operation	Setting Range	Setting Unit	Factory Setting	Valid Access Levels			
							GP	SL	PID	PG
Cn-06	Voltage At Middle Output Frequency	Cn-06=011.0V Middle Voltage		0.1~255.0V*1	0.1V	11.0V	1	2		1

(7) Min Output Frequency (Cn-07)

1. GP, PID, PG

Parameter No.	Name	LCD Display (English)	Change During Operation	Setting Range	Setting Unit	Factory Setting	Valid Access Levels			
							GP	SL	PID	PG
Cn-07	Min Output Frequency	Cn-07=001.5Hz Min O/P Freq.		0.1~400.0Hz	0.1Hz	1.5Hz	1	2	1	1

2. SL

Parameter No.	Name	LCD Display (English)	Change During Operation	Setting Range	Setting Unit	Factory Setting	Valid Access Levels			
							GP	SL	PID	PG
Cn-07	Min Output Frequency	Cn-07=001.0Hz Min O/P Freq.		0.1~400.0Hz	0.1Hz	1.0Hz	1	2	1	1

(8) Voltage At Min. Output Frequency (Cn-08)

1. GP, PG

Parameter No.	Name	LCD Display (English)	Change During Operation	Setting Range	Setting Unit	Factory Setting	Valid Access Levels			
							GP	SL	PID	PG
Cn-08	Voltage At Min. Output Frequency	Cn-08=011.0V Min. Voltage		0.1~255.0V*2	0.1V	11.0V	1	2	3	1

2. SL

Parameter No.	Name	LCD Display (English)	Change During Operation	Setting Range	Setting Unit	Factory Setting	Valid Access Levels			
							GP	SL	PID	PG
Cn-08	Voltage At Min. Output Frequency	Cn-08=004.3V Min. Voltage		0.1~255.0V*2	0.1V	4.3V	1	2	3	1

3. PID

Parameter No.	Name	LCD Display (English)	Change During Operation	Setting Range	Setting Unit	Factory Setting	Valid Access Levels			
							GP	SL	PID	PG
Cn-08	Voltage At Min. Output Frequency	Cn-08=013.0V Min. Voltage		0.1~255.0V*2	0.1V	13.0V	1	2	3	1

- Set inverter output frequency/voltage characteristics. (V/F characteristics).

(a) Changing V/F characteristics

Sn-02 = 0 to E: V/F characteristics determined by set value. Settings of Cn-02 to Cn-08 cannot be changed. (Refer to page 2-23).

Sn-02 = F: Any V/F characteristic can be obtained by the set values of constants Cn-02 to Cn-08.

(b) Voltage values (Cn-03, Cn-06, Cn-08) displayed in the operator depend on the set value of Sn-02 (V/F selection) as follows:

- Sn-02 = 0 to E: Proportional computation is performed with input voltage (Cn-01) as 100%

<Example> When Cn-01 = 220V and V/F pattern Sn-02 = 1, the following display is shown on the operator:

- Cn-03 = 220
- Cn-06 = $15V \times \frac{220}{200} = 16.5V$
- Cn-08 = $10V \times \frac{220}{200} = 11V$
- Sn-02 = F: The set value is displayed.

(c) When V/F characteristics are a straight line, the same value as Cn-07 is set in Cn-05. The set value of Cn-06 is disregarded.

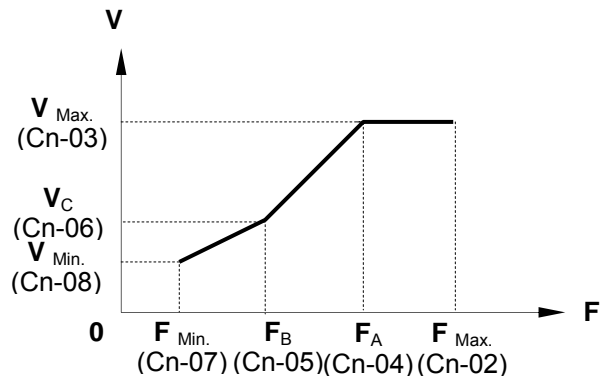

Notes:

1. The maximum output voltage is limited by input voltage.
2. When the set values of Cn-02 to Cn-08 do not satisfy the following conditions, a setting error occurs and " V/F Curve Incorrect (OPE10) " is displayed. The set value is checked at power ON and switching from PRGM mode to DRIVE mode. $F_{Max} \geq F_A > F_B \geq F_{Min}$.
3. Actual output voltage is limited to the following value even if an arbitrary V/F is set as Sn-02 = F. For setting without limit, set Sn-02 = FF. In this case, the inverter may malfunction unless V/F suitable for the motor characteristics is set.

7.5 to 30HP (5.5 to 22kW)

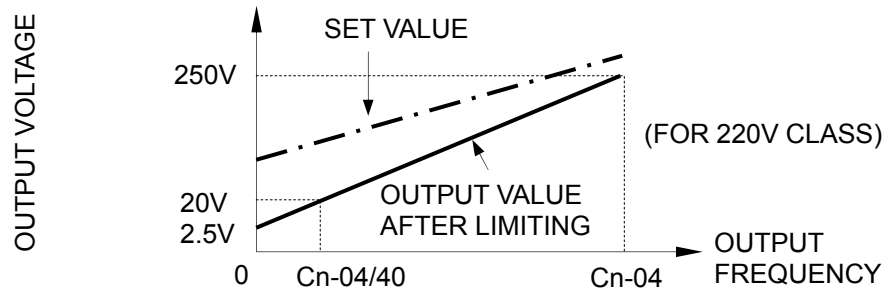

40 to 100HP (30 to 75kW), (40 to 400HP for 440V class)

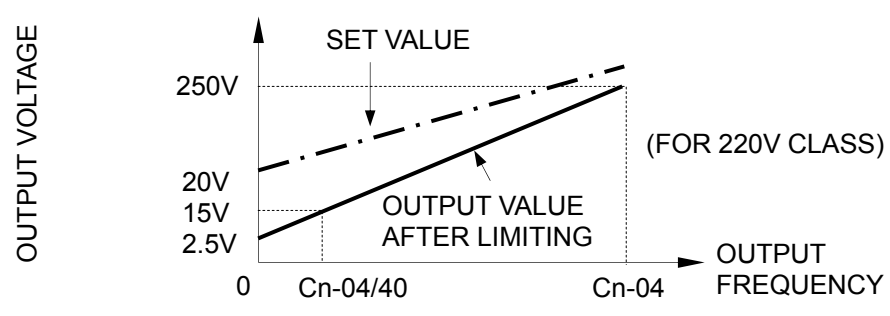

(9) Motor Rated Current (Cn-09)

Parameter No.	Name	LCD Display (English)	Change During Operation	Setting Range	Setting Unit	Factory Setting	Valid Access Levels			
							GP	SL	PID	PG
Cn-09	Motor Rated Current	Cn-09=031.0A Motor Rated I		*	0.1A	31A				

- Set motor rated current by the electronic thermal function in units of 0.1A for motor overload protection. The range of setting is 10% to 200% of inverter rated current. When the 1st digit of Sn-14 is 1, the electronic thermal function is disabled and the motor is not protected from overheating due to overload.

* Setting range becomes 10 to 200% of inverter rated current.

(10) DC Injection Braking Starting Frequency (Cn-10)

Parameter No.	Name	LCD Display (English)	Change During Operation	Setting Range	Setting Unit	Factory Setting	Valid Access Levels			
							GP	SL	PID	PG
Cn-10	DC Injection Braking Starting Frequency	Cn-10=01.5Hz DC Braking Start F		0.1~10.0Hz	0.1Hz	1.5Hz				

- Set a frequency for starting DC braking at deceleration stop in units of 0.1Hz. When a set value is not greater than Cn-07 (minimum output frequency), DC braking is started with the minimum output frequency.

(11) DC Braking Current (Cn-11)

Parameter No.	Name	LCD Display (English)	Change During Operation	Setting Range	Setting Unit	Factory Setting	Valid Access Levels			
							GP	SL	PID	PG
Cn-11	DC Braking Current	Cn-11=050% DC Braking Current		0~100%	1%	50%				

- Set DC braking current in units of 1%. Inverter rated current is 100%.

(12) DC Injection Braking Time At Stop (Cn-12)

1. GP, SL, PG

Parameter No.	Name	LCD Display (English)	Change During Operation	Setting Range	Setting Unit	Factory Setting	Valid Access Levels			
							GP	SL	PID	PG
Cn-12	DC Injection Braking Time At Stop	Cn-12=00.5s DC Braking Stop Time		0.0~25.5s	0.1s	0.5s	1	1	2	1

- Set the duration of DC braking at stopping in units of 0.1 second. When a set value is 0, DC braking is not performed, and inverter output is shut OFF at the start of DC braking.

2. PID

Parameter No.	Name	LCD Display (English)	Change During Operation	Setting Range	Setting Unit	Factory Setting	Valid Access Levels			
							GP	SL	PID	PG
Cn-12	DC Injection Braking Time At Stop	Cn-12=00.0s DC Braking Stop Time		0.0~25.5s	0.1s	0.0s	1	1	2	1

- Factory setting 0.0sec, DC braking is not performed.

(13) DC Injection Braking Time At Start (Cn-13)

Parameter No.	Name	LCD Display (English)	Change During Operation	Setting Range	Setting Unit	Factory Setting	Valid Access Levels			
							GP	SL	PID	PG
Cn-13	DC Injection Braking Time At Start	Cn-13=00.0s DC Braking Start Time		0.0~25.5s	0.1s	0.0s				

- Set the duration of DC braking at starting in units of 0.1 second. When a set value is 0, DC braking is not performed, and acceleration begins with the minimum output frequency.

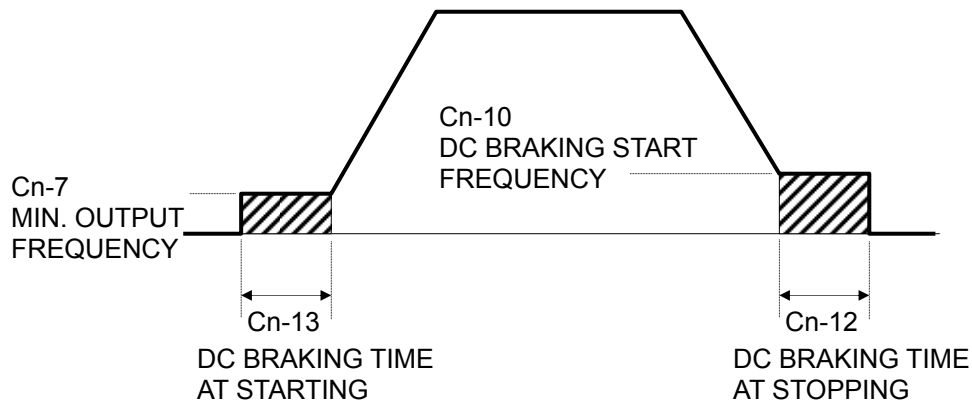

(14) Frequency Command Upper Bound (Cn-14)

(15) Frequency Command Lower Bound (Cn-15)

Parameter No.	Name	LCD Display (English)	Change During Operation	Setting Range	Setting Unit	Factory Setting	Valid Access Levels			
							GP	SL	PID	PG
Cn-14	Frequency Command Upper Bound	Cn-14=100% Freq. Cmd. Up Bound		0~109%	1%	100%				
Cn-15	Frequency Command Lower Bound	Cn-15=000% Freq. Cmd. Low Bound		0~109%	1%	0%				

- Set the lower limit of frequency reference in units of 1%. Cn-02 (maximum frequency) is regarded as 100%. When the run command is input with a frequency reference of 0, acceleration continues from the minimum frequency to the lower frequency reference limit, and operation continues in the lower frequency reference limit.

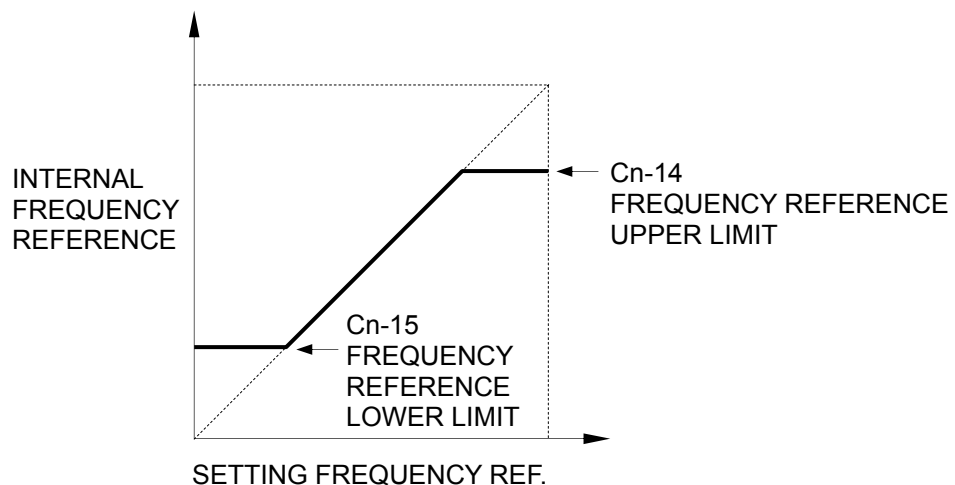

(16) Frequency Jump Point 1 (Cn-16)

(17) Frequency Jump Point 2 (Cn-17)

(18) Frequency Jump Point 3 (Cn-18)

Parameter No.	Name	LCD Display (English)	Change During Operation	Setting Range	Setting Unit	Factory Setting	Valid Access Levels			
							GP	SL	PID	PG
Cn-16	Frequency Jump Point 1	Cn-16=000.0Hz Frequency Jump 1		0.0~400.0Hz	0.1Hz	0.0Hz				
Cn-17	Frequency Jump Point 2	Cn-17=0.0Hz Frequency Jump 2		0.0~400.0Hz	0.1Hz	0.0Hz				
Cn-18	Frequency Jump Point 3	Cn-18=0.0Hz Frequency Jump 3		0.0~400.0Hz	0.1Hz	0.0Hz				

- Set a setting prohibit frequency in units of 0.1Hz. A set value of 0.0Hz disables this function.

Note: If the setting prohibit frequency ranges overlap, set prohibit (skip) frequency 1 to 3 as shown below:

$$\left(\begin{array}{c} \text{Cn-18} \\ \text{setting prohibit} \\ \text{frequency 3} \end{array} \right) \leq \left(\begin{array}{c} \text{Cn-17} \\ \text{setting prohibit} \\ \text{frequency 2} \end{array} \right) \leq \left(\begin{array}{c} \text{Cn-16} \\ \text{setting prohibit} \\ \text{frequency 1} \end{array} \right)$$

(19) Jump Frequency Width (Cn-19)

Parameter No.	Name	LCD Display (English)	Change During Operation	Setting Range	Setting Unit	Factory Setting	Valid Access Levels			
							GP	SL	PID	PG
Cn-19	Jump Frequency Width	Cn-19=01.0Hz Freq. Jump Width		0.0~25.5Hz	0.1Hz	1.0Hz				

- Set the range of setting prohibit (skip) frequency in units of 0.1Hz. The range of the setting prohibit (skip) frequency is determined as follows, depending on combinations with Cn-16 to Cn-18.

Cn-16 to Cn-18 - Cn-19 \leq the range of the setting prohibit frequency \leq Cn-16 to Cn-18 + Cn-19.

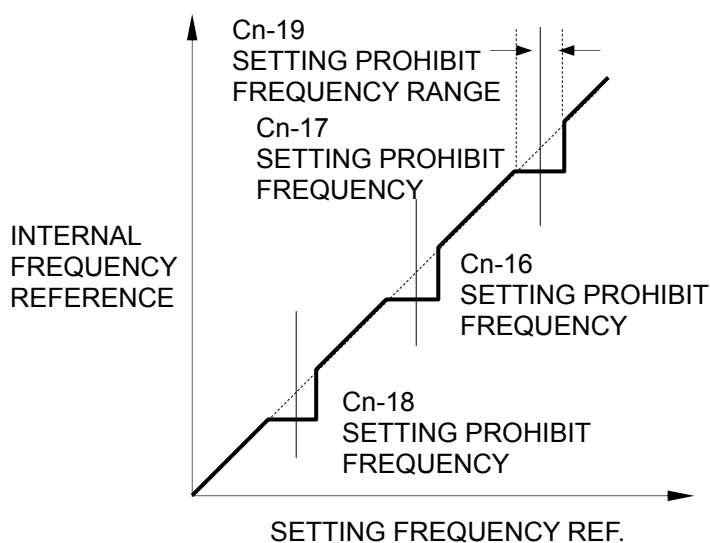

Note: Constant speed operation is prohibited in the setting prohibit frequency range. Output frequency does not jump during acceleration or deceleration, which is performed smoothly.

(20) Digital Operator Display Unit (Cn-20)

Parameter No.	Name	LCD Display (English)	Change During Operation	Setting Range	Setting Unit	Factory Setting	Valid Access Levels			
							GP	SL	PID	PG
Cn-20	Digital Operator Display Unit	Cn-20=00000 Operator DSPL Unit		0~39999	1	0				

- The setting unit of frequency references 1 to 8 and jog frequency reference depends on the set value of operator display mode (Cn-20) as follows:

Cn-20	Setting / Reading Unit
0	Units of 0.01Hz
1	Units of 0.01%
2 to 39	Set in the units of r/min (0 to 39999). r/min = 120 x frequency reference (Hz)/Cn-20 (Set the number of motor poles in Cn-20).
40 to 39999	The position of decimal point is set by the value of the 5th digit of Cn-20. Value of 5th digit = 0: Displayed as XXXX Value of 5th digit = 1: Displayed as XXX.X Value of 5th digit = 2: Displayed as XX.XX Value of 5th digit = 3: Displayed as X.XXX A set value of 100% frequency is determined by the 1st digit to 4th digit of Cn-20. Example 1: When the set value of 100% speed is 200.0, Cn-20 = 12000 is set. 100% speed is displayed as 200.0 at Cn-20 = 12000. 60% speed is displayed as 120.0 Example 2: When the set value of 100% speed is 65.00, Cn-20 = 26500 is set. 60% speed is displayed as 39.00 at Cn-20 = 26500.

(21) Frequency Agree Detection Level (Cn-21)

(22) Frequency Agree Detection Width (Cn-22)

Parameter No.	Name	LCD Display (English)	Change During Operation	Setting Range	Setting Unit	Factory Setting	Valid Access Levels			
							GP	SL	PID	PG
Cn-21	Frequency Agree Detection Level	Cn-21=000.0Hz F Agree Det. Level		0.0~400.0Hz	0.1Hz	0.0Hz				
Cn-22	Frequency Agree Detection Width	Cn-22=02.0Hz F Agree Det. Width		0.1~25.5Hz	0.1Hz	2.0Hz				

- Set an agreed frequency detection width in units of 0.1Hz. The relationship with the multi-function contact outputs are shown in the four figures below [(a) to (d)].

(a) Agreed frequency (set value of multi-function contact output = 2)

This is "closed" when output frequency is within the detection width shown in the following figure.

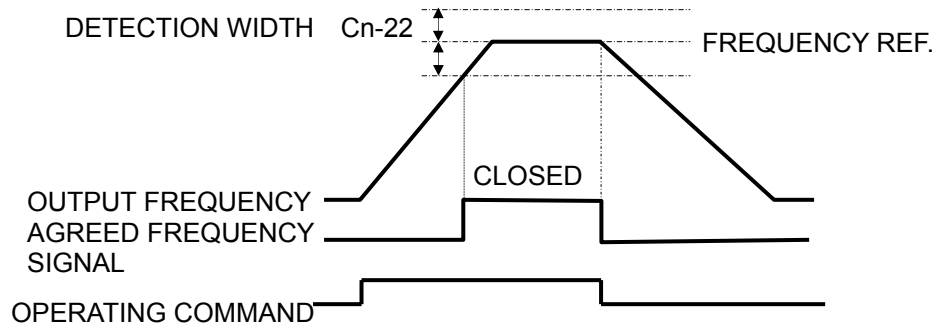

$$(\text{Frequency ref.} - \text{Cn-22}) \leq \text{Output frequency} \leq (\text{Frequency ref.} + \text{Cn-22})$$

Cn-21: Agreed frequency point.

Cn-22: Agreed frequency detection width.

(b) Agreed frequency (set value of multi-function contact output = 3)

This is "closed" when acceleration or deceleration is completed and output frequency is within the detection width shown in the figure below.

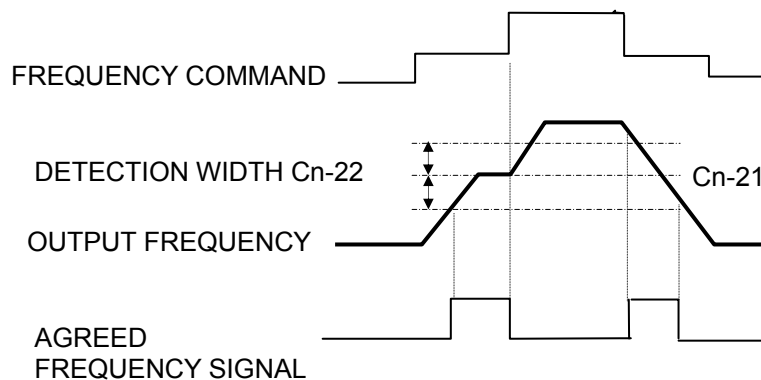

$$(\text{Cn-21} - \text{Cn-22}) < \text{Output frequency} < (\text{Cn-21} + \text{Cn-22})$$

Cn-21: Agreed frequency point.

Cn-22: Agreed frequency detection width.

- (c) Frequency detection contact (set value of multi-function contact output = 4)
 This contact is "closed" when output frequency is equal to or less than Cn-21, as shown in the figure below.

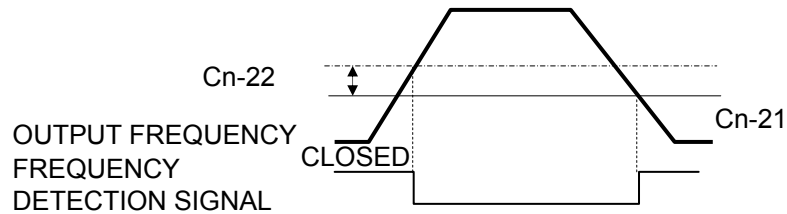

Output frequency \leq Cn-21

Cn-21: Agreed frequency point.

Cn-22: Agreed frequency detection width.

- (d) Frequency detection contact (set value of multi-function contact output = 5)
 This contact is "closed" when output frequency is equal to or more than Cn-21, as shown in the figure below.

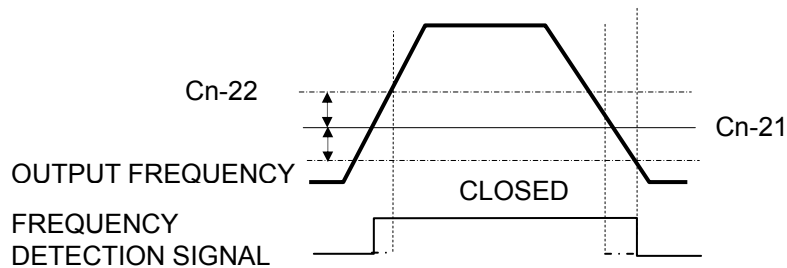

Output frequency \geq Cn-21

Cn-21: Agreed frequency point.

Cn-22: Agreed frequency detection width.

(23) Carrier Frequency Upper Limit (Cn-23)

(24) Carrier Frequency Lower Limit (Cn-24)

(25) Carrier Frequency proportion Gain (Cn-25)

Parameter No.	Name	LCD Display (English)	Change During Operation	Setting Range	Setting Unit	Factory Setting	Valid Access Levels			
							GP	SL	PID	PG
Cn-23	Carrier Frequency Upper Limit	Cn-23=6.0KHz Carry-Freq. Up Bound		0.4~15.0KHz*6	0.1KHz	6.0KHz*6				
Cn-24	Carrier Frequency Lower Limit	Cn-24=6.0KHz Carry-Freq. Low Bound		0.4~15.0KHz*6	0.1KHz	6.0KHz*6				
Cn-25	Carrier Frequency proportion Gain	Cn-25=00 Carry-Freq. P_Gain		0~99	1	0*5				

- The relationship between output frequency and carrier frequency is determined as follows from the set values of Cn-23 to Cn-25.

(a) For constant carrier frequency (set value of Cn-23):

Set 0 in Cn-25 and set the same value in Cn-23 and Cn-24.

(b) For carrier frequency: Carrier frequency changes according to Cn -23 to Cn-25 set values and output frequency as shown below.

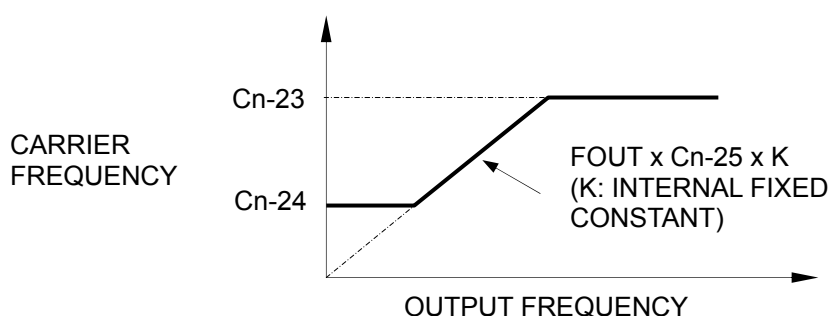

“ Carry_Freq Incorrect (OPE11) Alarm” is displayed in the following cases:

- 1 Cn-25 > 6 and Cn-24 > Cn-23
- 2 Cn-23 > 5kHz and Cn-24 ≤ 5kHz

(26) Overtorque Detection Level (Cn-26)

(27) Overtorque Detection Time (Cn-27)

Parameter No.	Name	LCD Display (English)	Change During Operation	Setting Range	Setting Unit	Factory Setting	Valid Access Levels			
							GP	SL	PID	PG
Cn-26	Overtorque Detection Level	Cn-26=160% Over Tq. Det. Level		30~200%	1%	160%				
Cn-27	Overtorque Detection Time	Cn-27=00.1s Over Tq. Det. Time		0.0~25.5s	0.1s	0.1s				

- Set overtorque level in units of 1%. Inverter rated current is regarded as 100%.
- Set overtorque detection time in units of 0.1 second.

(28) Stall Prevention Level During Acceleration (Cn-28)

Parameter No.	Name	LCD Display (English)	Change During Operation	Setting Range	Setting Unit	Factory Setting	Valid Access Levels			
							GP	SL	PID	PG
Cn-28	Stall Prevention Level During Acceleration	Cn-28=170% ACC. Stall		30~200%	1%	170%				

- Set stall prevention level during acceleration in units of 1%. Inverter rated current is regarded as 100%.

(29) Constant HP Area stall prevention (Cn-29)

Parameter No.	Name	LCD Display (English)	Change During Operation	Setting Range	Setting Unit	Factory Setting	Valid Access Levels			
							GP	SL	PID	PG
Cn-29	Constant HP Area stall prevention	Cn-29=050% CH* Acc. Stall		30~200%	1%	50%				

- Set constant HP (kW) area stall prevention level in units of 1%. Inverter rated current is regarded as 100%.
- The function of stall prevention during acceleration automatically extends acceleration according to load status (inverter output current), thus preventing the motor from stalling during acceleration. The stall prevention level during acceleration in a constant output area is reduced as follows:
- When the 1st digit of Sn-10 is 1, the output frequency increases at the rate determined by acceleration time:

$$\text{Acceleration stall prevention level of constant output area} = \frac{\text{Acceleration stall prevention level (Cn-28)} \times \text{Maximum voltage frequency (Cn-04)}}{\text{Output frequency}}$$

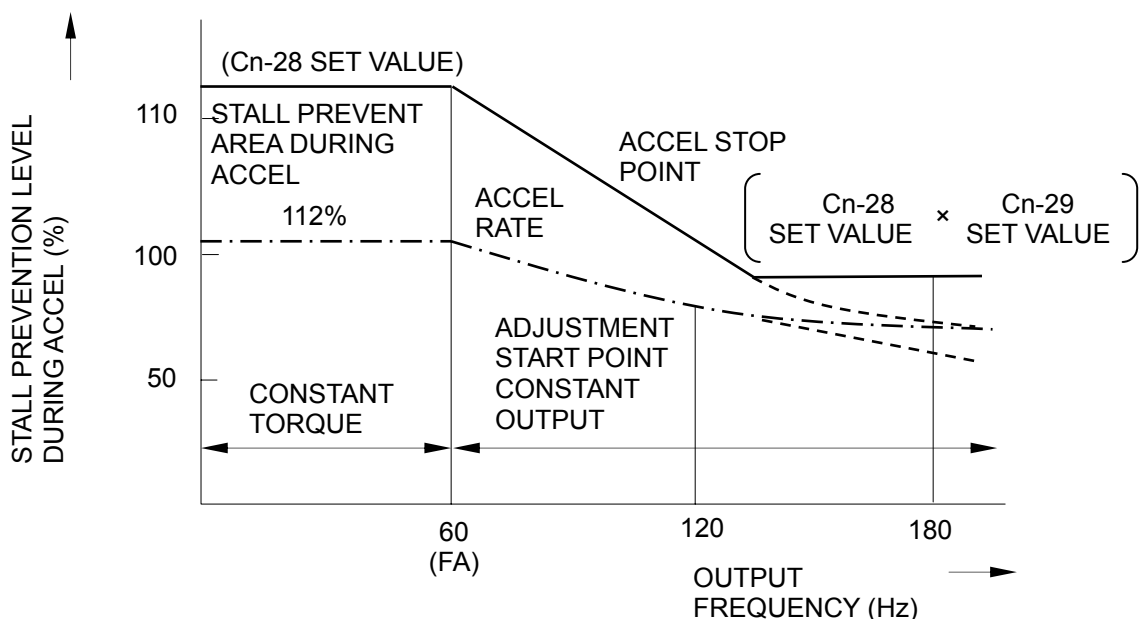

(30) Stall Prevention Level During Running (Cn-30)

Parameter No.	Name	LCD Display (English)	Change During Operation	Setting Range	Setting Unit	Factory Setting	Valid Access Levels			
							GP	SL	PID	PG
Cn-30	Stall Prevention Level During Running	Cn-30=160% Running Stall		30~200%	1%	160%				

- Set a proportion as a stall prevention level during running in units of 1%. Inverter rated current is regarded as 100%
- Stall prevention during running starts deceleration when the output current is greater than the setting value of Cn-30 during agreed frequency for more than 100ms. The inverter decelerates as long as the output current exceeds the setting value of Cn-30 (stall prevention level during running). When the output current goes below the setting value, the inverter reaccelerates. The deceleration time selected in the 4th digit of Sn-10 is taken.
- Even during stall prevention while running, stall prevention during deceleration and stall prevention during acceleration are enabled.

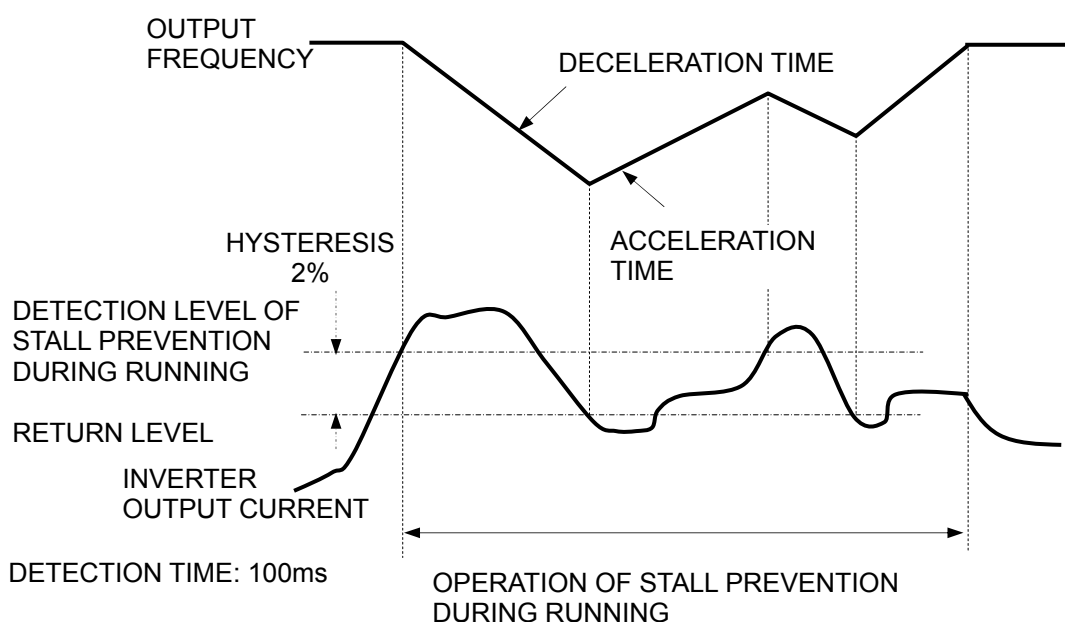

(31) Motor Terminal Resistance (Cn-31)

Parameter No.	Name	LCD Display (English)	Change During Operation	Setting Range	Setting Unit	Factory Setting	Valid Access Levels			
							GP	SL	PID	PG
Cn-31	Motor Terminal Resistance	Cn-31=0.308Ω Motor Line R		0~65.535Ω	0.001Ω	0.308Ω				

- It is for torque compensation function. The default setting depends upon the inverter capacity (Sn-01). Normally, the setting does not need to be altered.

(32) Motor Iron Loss (Cn-32)

1. GP, PID, PG

Parameter No.	Name	LCD Display (English)	Change During Operation	Setting Range	Setting Unit	Factory Setting	Valid Access Levels			
							GP	SL	PID	PG
Cn-32	Motor Iron Loss	Cn-32=425W Core Loss		0~65535W	1W	425W	1	2	1	1

- It is for torque compensation function. The default setting depends upon the inverter capacity (Sn-01). Normally, the setting does not need to be altered.

2. SL

Parameter No.	Name	LCD Display (English)	Change During Operation	Setting Range	Setting Unit	Factory Setting	Valid Access Levels			
							GP	SL	PID	PG
Cn-32	Motor Leakage Inductance (LS)	Cn-32=005.54mH Equivalent Leakage L		0.00~200.00mH	0.1mH	5.54mH*	1	2	1	1

- Set motor leakage inductance in the units 0.01mH.
- Set motor leakage inductance and externally-mounted reactor values when a reactor is connected between the inverter and motor.

* Factory settings differ depending on inverter capacity (Sn-01 set value).

(33) Torque Compensation Limiter (Cn-33)

1. GP, PID, PG

Parameter No.	Name	LCD Display (English)	Change During Operation	Setting Range	Setting Unit	Factory Setting	Valid Access Levels			
							GP	SL	PID	PG
Cn-33	Torque Compensation Limiter	Cn-33=100V Tq. Comp. Limit		0~50V*1	1V	100V	1	2	1	1

- For 440V class, the setting range and initial value are doubled.
- Factory settings differ depending on inverter capacity (Sn-01 set value).

2. SL

Parameter No.	Name	LCD Display (English)	Change During Operation	Setting Range	Setting Unit	Factory Setting	Valid Access Levels			
							GP	SL	PID	PG
Cn-33	Torque Limiter	Cn-33=150% Torque Limit		0~200%	1%	150%	1	2	1	1

- Sets the upper limit of motor torque in the units of 1%. For example, When it is set to 150%, motor generating torque becomes 1.5 times as large as motor rated torque at the maximum.

(34) Motor No Load Current (Cn-34)

Parameter No.	Name	LCD Display (English)	Change During Operation	Setting Range	Setting Unit	Factory Setting	Valid Access Levels			
							GP	SL	PID	PG
Cn-34	Motor No Load Current	Cn-34=030% Motor No_Load I		0~99%	1%	30%				

- Set motor no load current in units of 1%. Motor rated current (Cn-09) is regarded as 100%.
- When the output current of the inverter is larger than motor no-load current (Cn-34), the output frequency of the inverter is compensated.
- The amount of frequency compensation is determined by the formula below.
- The maximum voltage frequency (Cn-04) is 100% level.

If the output current is compensated for by the motor rated slip (bn-08).

If frequency reference is equal to or smaller than minimum output frequency (Cn-07) or motor is in a regeneration mode, slip compensation is not performed.

Amount of output frequency compensation =

$$\frac{\text{Motor rated slip}}{\left(\frac{\text{Motor rated current} - \text{Motor no-load current}}{\text{Motor rated current}} \right)} \times \left(\frac{\text{Output current} - \text{Motor no-load current}}{\text{Motor rated current}} \right)$$

Motor rated current: Cn-09

Motor no load current: Cn-34

Motor rated slip: bn-08

- The amount of output frequency compensation in a constant torque area and a constant output area is shown in the figure below.

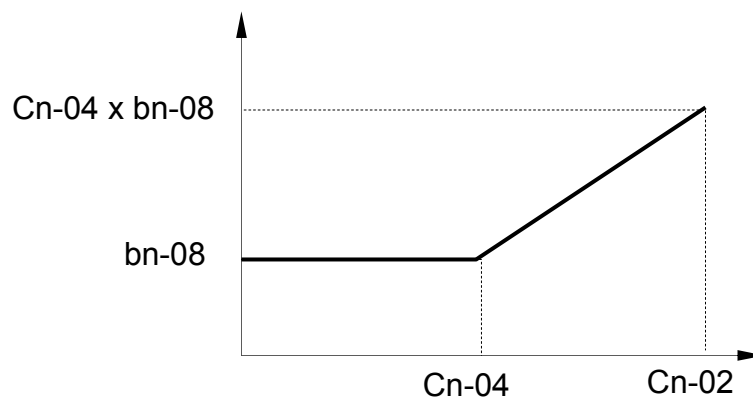

* Motor rated current (Cn-09) becomes 100% level. Factory settings differ depending on inverter capacity (Sn-01 Set value) in SL control mode.

(35) Slip Compensation Delay time (Cn-35)

1. GP, PID, PG

Parameter No.	Name	LCD Display (English)	Change During Operation	Setting Range	Setting Unit	Factory Setting	Valid Access Levels			
							GP	SL	PID	PG
Cn-35	Slip Compensation Delay time	Cn-35=02.0s Slip Filter		0.0~25.5s	0.1s	2.0s	1	2		

- Set slip compensation primary delay time in units of 0.1 second.

2. SL

Parameter No.	Name	LCD Display (English)	Change During Operation	Setting Range	Setting Unit	Factory Setting	Valid Access Levels			
							GP	SL	PID	PG
Cn-35	Slip Compensation Delay time	Cn-35=0.2s Slip Filter		0.0~25.5s	0.1s	0.2s	1	2		

(36) Number of Auto Restart Attempt (Cn-36)

Parameter No.	Name	LCD Display (English)	Change During Operation	Setting Range	Setting Unit	Factory Setting	Valid Access Levels			
							GP	SL	PID	PG
Cn-36	Number of Auto Restart Attempt	Cn-36=00 Retry Time		0~10	1	0				

- Set the number of auto reset/restart operation. Setting of zero causes no auto reset/restart operation.
- Each time one of these faults occur: OC, OV, OL1, OL2, OL3, OH, UV1 (OC, GF, OV, rr or UV1), one is added to the number of auto reset/restart operation, and auto reset/restart operation is performed according to the following procedure. However, auto reset/restart operation is not performed in the following cases:
 - 1 When operation not continued at momentary power loss (3rd digit of Sn-11 = 0) is specified, UV1 fault is not automatically reset.
 - 2 When OC or OV fault occurs due to external fault during deceleration stop or DC injection braking stop, inverter output is shut OFF.
- The number of auto reset/restart operation is cleared to zero when:
 - 1 No fault occurs for 10 minutes or more.
 - 2 A fault reset signal is input from control circuit terminals or digital operator.
- Auto reset/restart operation
 - 1 When a fault is detected, inverter output is shut OFF for the minimum baseblock time (Cn-40). During shut OFF of inverter output, a fault occurring in the operator is displayed.
 - 2 When the minimum baseblock time (Cn-40) elapses, the fault is automatically reset, and speed search operation is performed with the output frequency at the time of the fault.
 - 3 When the total number of faults exceeds the number of auto restart attempts (Cn-36), automatic reset is not performed and inverter output is shut OFF. At this time, fault contact output is output.

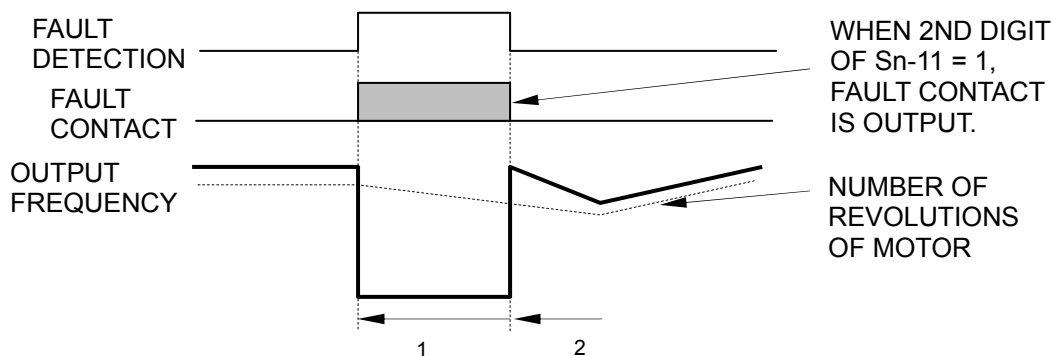

(37) Power Loss Ride-thru Time (Cn-37)

Parameter No.	Name	LCD Display (English)	Change During Operation	Setting Range	Setting Unit	Factory Setting	Valid Access Levels			
							GP	SL	PID	PG
Cn-37	Power Loss Ride-thru Time	Cn-37=2.0s Ride-thru Time		0~2.0s	0.1s	2.0s*4				

- Set in units of 0.1 second. The initial value depends on the inverter capacity.

(38) Speed Search Detection Level (Cn-38)

Parameter No.	Name	LCD Display (English)	Change During Operation	Setting Range	Setting Unit	Factory Setting	Valid Access Levels			
							GP	SL	PID	PG
Cn-38	Speed Search Detection Level	Cn-38=150% SP_Search Level		0~200%	1%	150%				

- When inverter output current immediately after power recovery is larger than the set value of Cn-38, speed search operation is started. When inverter output current is smaller than the set value of Cn-38, the frequency is interpreted as a speed synchronization point and acceleration or deceleration is performed again up to a specified frequency.

(39) Speed Search Time (Cn-39)

Parameter No.	Name	LCD Display (English)	Change During Operation	Setting Range	Setting Unit	Factory Setting	Valid Access Levels			
							GP	SL	PID	PG
Cn-39	Speed Search Time	Cn-39=02.0s SP_Search Time		0.1~25.5s	0.1s	2.0s				

- Set deceleration time during speed search in units of 0.1 second. A setting of 0.0 second causes no speed search.

(40) Min. Baseblock Time (Cn-40)

Parameter No.	Name	LCD Display (English)	Change During Operation	Setting Range	Setting Unit	Factory Setting	Valid Access Levels			
							GP	SL	PID	PG
Cn-40	Min. Baseblock Time	Cn-40=1.0s Min. B.B. Time		0.5~5.0s	0.1s	1.0s				

- On detecting momentary power loss, the inverter shuts OFF output and maintains the baseblock state for a given time. Set a time in Cn-40 when residual voltage is expected to be almost zero.
- When momentary power loss time is longer than the minimum baseblock time, speed search operation is started immediately after power recovery.

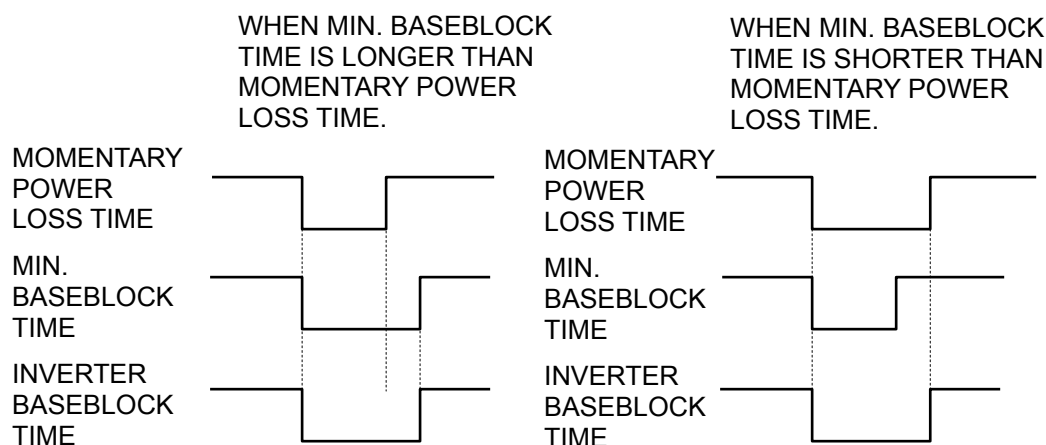

(41) V/F Curve in Speed Search (Cn-41)

Parameter No.	Name	LCD Display (English)	Change During Operation	Setting Range	Setting Unit	Factory Setting	Valid Access Levels			
							GP	SL	PID	PG
Cn-41	V/F Curve in Speed Search	Cn-41=100% SP_Search V/F Curve		10~100%	1%	100%				

- To ensure that a fault such as OC does not occur during speed search operation, V/F must be reduced during speed search operation, as compared with that during normal operation. Set V/F during speed search as follows by the set value of Cn-41:

$$\text{V/F during speed search} = \text{V/F at normal operation} \times \text{Cn-41}$$

(42) Voltage Recovery Time (Cn-42)

Parameter No.	Name	LCD Display (English)	Change During Operation	Setting Range	Setting Unit	Factory Setting	Valid Access Levels			
							GP	SL	PID	PG
Cn-42	Voltage Recovery Time	Cn-42=0.3s Voltage Recovery		0.1~5.0s	0.1s	0.3s				

- Set in Cn-42 the time between completion of speed search operation and return to V/F at normal operation. The setting of voltage recovery time is set as follows:

220V class: Time required to raise voltage from 0 to 230V

440V class: Time required to raise voltage from 0 to 460V

2.6 Monitoring Parameters Un -

Parameter No.	Name	LCD Display (English)	Unit	Descriptions	Valid Access Levels			
					GP	SL	PID	PG
Un-01	Frequency Command	Un-01=60.00Hz Frequency Command	0.01Hz	Display frequency command, the displayed unit is determined by Cn-20				
Un-02	Output Frequency	Un-02=60.00Hz Output Frequency	0.01Hz	Display output frequency, the displayed unit is determined by Cn-20				
Un-03	Output Current	Un-03=12.5A Output Current	0.1A	Display inverter output current				
Un-04	Output Voltage	Un-04=220.0V Output Voltage	0.1V	Display output voltage command of inverter				
Un-05	Main Circuit DC Voltage	Un-05=310.0V DC Voltage	0.1V	Display DC voltage of inverter main circuit				
Un-06	Output Power	Un-06= KW Output Power	0.1KW	Display output power of inverter				
Un-07	Input Terminal Status	Un-07=00000000 I/P Term. Status	-					
Un-08	Output Terminal Status	Un-08=00000000 O/P Term. Status	-					
Un-09	LED Lamp Cheek	Un-09=65535 LED Cheek	-	LED Lamp Cheek (for JNEP-33 Digital operator)				
Un-10	S/W Version	Un-10=00001 Software Version	-	- Manufacturing use -				

Parameter No.	Name	LCD Display (English)	Unit	Descriptions	Valid Access Levels			
					GP	SL	PID	PG
Un-11	Control Mode Select	Setting V/F Ctrl Mode	-	V/F Control mode while Sn-13=00 (factory setting)				
		Setting SL Ctrl Mode	-	Sensorless Vector Control mode while Sn-13=01				
		Setting PID Ctrl Mode	-	PID with Auto Energy Saving Control mode while Sn-13=10				
		Setting PG Ctrl Mode	-	V/F=PG Closed loop Control mode while Sn-13=11				
Un-12	Monitoring Output Select	Un-12=100% Output Torque	1%	Output torque at SL Control mode (motor rated torque=100%)				
		Un-12=0.9 Output P.F.	0.1	Output Power factor at PID Control mode		1	2	3
		Un-12=100.0% Speed Feedback	0.1%	Amount of speed feedback at PG Control mode. (display unit=0.1% of max. output frequency)				
Un-13	Amount of Speed Control Compensation	Un-13=10.0% Speed Ctrl Comp.	0.1%	Amount of speed control compensation at PG Control mode. (display unit=0.1% of max. output frequency)				

*1. The display status for JNEP-33 LED operator :

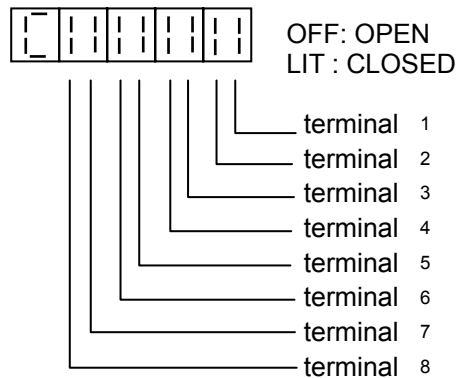

*2. The display status for JNEP-33 LED operator

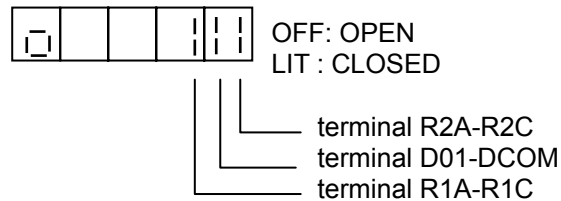

3. FAULT DISPLAY AND TROUBLESHOOTING

The 7200GAS has protection functions and warning self-diagnosis functions. If a fault occurs, the protection functions operate to shut OFF the inverter output and the motor coasts to stop, at the same time, the fault contact signal (terminal 18 - 20 , 19 - 20) is output.

A). PROTECTIVE FUNCTIONS AND TROUBLESHOOTING

Protection function		Explanation	LCD display (English)
Low voltage protection	Main circuit low voltage	When the inverter power voltage drops, torque becomes insufficient and motor is overheated.	Fault (UV1)* ¹ DC Volt. Low
	Momentary power loss protection	Inverter output is stopped when the main circuit DC voltage becomes lower than the low voltage detection level for 15 ms or longer. or about 2 seconds or longer if the momentary power loss redo-thru function is used. Detection level: Approximately 210V or less for 220V class and 420V or less for 440V class	
	Control circuit low voltage	The inverter output is shut-off when the control circuit voltage drops below the low voltage level.	Fault (UV2)* ¹ C/B DC Volt. Low
	Main circuit soft charge contactor defective	The inverter output is shut-off when no answer back is received from the main circuit soft-start contactor.	Fault (UV3)* ¹ MC Ans. Fault
Overcurrent protection		The inverter output is shut-off when the inverter output current becomes approx. 200% and above of inverter rated current.	Fault (OC)* ¹ Over Current
Ground-fault protection		The inverter output is shut-off when a ground-fault occurs at the inverter output side and the ground-fault current exceeds approximately 50% of the inverter rated current.	Fault (GF)* ¹ Ground Fault
Overvoltage protection		The inverter output is shut-off when the main circuit DC voltage becomes excessive because of regeneration energy caused by motor deceleration and negative load. Detection. Approx. 800V for input voltage set 400V and above Level : Approx. 700V for input voltage set 400V or less Approx. 400V for 200V class	Fault (OV)* ¹ Over Voltage
Cooling fin overheat		The inverter output is shut-off when the ambient temperature rises and the heat sink fin reaches 105 . Please check for a defective cooling fan or clogged filter.	Fault (OH)* ¹ Over Heat
Overload protection	Motor	Inverter output is stopped when motor overload is detected by the electronic thermal overload in the inverter. Either a inverter duty constant-torque specialized motor or general-purpose motor can be selected. If more than one motor is driven, overload protection should be disabled. Use a thermal relay or thermal protector for each motor.	Fault (OL1)* ¹ Motor Over Load
	Inverter	The inverter output is shut-off when the electronic thermal overload reaches or exceeds the inverse time limit of 103% of the inverter's rated current occurs. Maximum rated overload: 110%. 1 min.	Fault (OL2)* ¹ Inverter Over Load
	Over torque detection	The motor operates according to a preset mode when the inverter output current exceeds the overtorque detection level. This function is used to protect the machine or to monitor the output torque.	Fault (OL3)* ¹ Over Torque
External fault signal input	Terminal 3	When an external alarm signal is input, the inverter operates according to a preset stop method (coasting to a stop, continuous operation, or ramp to stop)	Fault (EF3)* ¹ External Fault 3
	Terminal 5		Fault (EF5)* ¹ External Fault 5
	Terminal 6		Fault (EF6)* ¹ External Fault 6
	Terminal 7		Fault (EF7)* ¹ External Fault 7
	Terminal 8		Fault (EF8)* ¹ External Fault 8
Control Circuit Fault	Control Circuit Fault	The inverter output is shut-off when a transmission error occurs in the control circuit or a component fails. The inverter output is also shut-off when a specialized option such as the digital operator is not properly connected.	Fault (CPF02)* ¹ Logic board Fault
	EEPROM fault		Fault (CPF03)* ¹ EEPROM Fault
	EEPROM BCC CODE Error		Fault (CPF04)* ¹ EEPROM CODE Err.
	CPU ADC Fault		Fault (CPF05)* ¹ A/D Fault
	Option Card Fault		Fault (CPF06)* ¹ Opt. Card A/D Fault
	EPROM Address Error		Fault (CPF30)* ¹ EPROM Add. Err.

The warning and self-diagnosis functions do not operate fault contact output (except OH1 warning function) and returns to the former operation status automatically when the factor is removed.

The fault display and troubleshooting are listed as shown in the table below.

Fault Contact output	Error causes	Action to be taken
Operation	<ul style="list-style-type: none"> ● Inverter capacity is too small. ● Voltage drop due to wiring. ● Inverter power voltage selection is wrong ● A motor of large capacity (11 kW or greater) connected to the same power system has been started. ● Rapid acceleration with generator power supply ● Operation sequence when power is off ● Defective electromagnetic contactor 	<ul style="list-style-type: none"> ● Check the power capacity and power system. ● UV display appears when the inverter power is turned off while operation signal is input. Remove the power after stopping the inverter. (Set the third and fourth bits of Sn-04 to 01.)
Operation	<ul style="list-style-type: none"> ● Extremely rapid accel/decel ● Motor on/off switching at the inverter output side ● Short-circuit or ground-fault at the inverter output side ● Motor of a capacity greater than the inverter rating has been started ● High-speed motor or pulse motor has been started. 	Transistor error may occur. Investigate the error cause, correct it, then restart.
Operation	<ul style="list-style-type: none"> ● Motor dielectric strength is insufficient. ● Load wiring is not proper. 	Check for ground-fault in motor or load wiring.
Operation	<ul style="list-style-type: none"> ● Over voltage ● Insufficient deceleration time ● Regenerative load (Motor is turned by the load.) ● High input voltage compared to motor rated voltage 	If braking torque is not proper, extend the decel time or use a braking resistor. (If braking resistor is already installed, verify that Sn-10. 2nd digit to 1.)
Operation	<ul style="list-style-type: none"> ● Defective cooling fan. ● Ambient temperature rise ● Clogged filter 	Replace the cooling fan and clean the filter. Ambient temperature: 104 (40) or less for enclosed type 122 (45) or less for open chassis
Operation	Overload, low speed operation or extended acceleration time, improper V/f characteristic setting	Investigate the cause of overload and review the operation pattern, V/f characteristic, and motor/inverter capacities. (If inverter is repeatedly reset after an overload occurs, the inverter may fault. Investigate and correct the cause of overload.)
Operation	Motor current exceeds the preset value because of machine error or overload.	Check the use of the machine. Correct the overload cause or set a higher detection level which is within the allowable range.
Operation	External fault condition occurred.	Correct the Cause of the fault input.
Operation	<ul style="list-style-type: none"> ● External noise ● Excess vibration or shock. ● CPF 02: Control circuit fault. ● CPF 03: NVRAM (SRAM) fault. ● CPF 04: NVRAM BCC Code error. ● CPF 05: AD converter fault in CPU. ● CPF 06: Option Card fault. ● CPF 30: EEPROM Addressing Error. 	Check data in Sn-01 and Sn-02. Record all data, then use, Sn-03 for initializing. Turn off power, then turn on again. If error is persistent, contact your TECO representative.

Protection function	Explanation	LCD display (English)
Parameter Setting Error	Parameter Setting Error	Fault (Err)* ¹ Parameter
PG line broken	Stopping method can be selected	Fault (PGo)* ¹ PG Open
Overspeed	Excessive PG speed fault, stopping method can be selected.	Fault (oS)* ¹ PG Over Sp.
Excessive deviation	Excessive speed deviation, stopping method can be selected.	Fault (dEu)* ¹ Sp. Deviat. Over
AI-14B A/D fault	<ul style="list-style-type: none"> ● AI-14B option card A/D fault ● External noise or excessive vibration or shock. 	Fault (CPF20)* ¹ AI-14B A/D Fault
Watchdog Error (SI-M card)	Communication option card Watchdog time active.	Fault (CPF21)* ¹ SI-M Comm. Fault 1
Dual Port RAM FAULT (SI-M card)	Communication option card Dual port RAM fault.	Fault (CPF23)* ¹ SI-M Comm. Fault 2
SI-M transmission error	When any communication error between communication option card (SI-M) and master controller occurs, the inverter operates according to a preset stop method (Sn-08)	Fault (buS)* ¹ SI-M Comm. Fault 3

* 1. The display contents of LED digital operator.

Fault Contact output	Error causes	Action to be taken
Operation	●Parameter setting error	●Check the parameter setting.
Operation	●The PG wiring is not properly connected or open-circuit.	●Check the PG wiring.
Operation	●Improper setting of ASR parameter or over-speed protection level.	●Check the parameter of ASR and the protection level.
Operation	●Improper setting of ASR parameter or speed deviation level.	●Check the parameter of ASR and speed deviation level.
Operation	●AI-14B option card A/D Fault. ●External noise. ●Excessive vibration or shock.	●Turn off power, then turn on again. If error is persistent, replace the option card.
Operation	●RS-485 communication option card fault. ●External noise. ●Excessive vibration or shock.	●Turn off power, then turn on again. If error is persistent, replace the option card.
Operation		
Operation		

B.) Warning and Self-Diagnosis Functions

Protection function		Explanation	LCD display (English)
Low-voltage protection { main circuit voltage } insufficient		Monitor display appears if low voltage protection conditions such as a drop in main circuit voltage or momentary power loss occur while the inverter output is OFF.	(blinking) Alarm (UV)* ¹ DC Volt. Low
High voltage protection		Monitor display appears when the main circuit DC voltage rises above the detection level while the inverter output is OFF.	(blinking) Alarm (OV)* ¹ Over Voltage
Cooling fin overheat warning		Monitor display appears when a separate thermal protector contact is input to the external terminal.	(blinking) Alarm (OH2)* ¹ Over Heat
Overtorque detection		This function is used to protect the machine and to monitor the inverter output torque. The inverter output reacts in a preset manner when the inverter output current exceeds the over torque detection level. The monitor display blinks when "operation continue" is preset.	(blinking) Alarm (OL3)* ¹ Over Torque
Stall prevention { Accel/decel is accomplished with maximum capacity of the inverter without tripping on over-current or overvoltage a }	During acceleration	Inverter acceleration is stopped when 150% of or more of the inverter rated current is required by the load. This prevents overload protection (OL2) or overcurrent (OC) from occurring. When current is reduced to less than 170%, acceleration is enabled.	-
	During normal operation	Output frequency is decreased when 130% of the inverter rated current or greater is required by the load. This prevents motor and inverter overload (OL1, OL2). When current is reduced below 130%, inverter acceleration is then enabled.	
	During deceleration	Deceleration is stopped when the DC voltage is caused to rise by motor regenerative energy. This prevents overvoltage trips (OV). When DC voltage decreases, deceleration to the set value then resumes	
Simultaneous normal and reverse rotation commands		When forward and reverse rotation commands are simultaneously detected for a period of time exceeding 500 ms, the inverter is stopped according to the preset stop method.	(blinking) Alarm (EF)* ¹ Input Error
External Fault Signal Input (Minor fault)	Terminal 3	It is indicated on the monitor when the mode after external signal input is set to "Operation continue." ●Ref. to the external faults 5 ~ 8 setting. Minor fault setting - terminal 3 (Sn-12=11XX) terminal 5 (Sn-15=2C) terminal 6 (Sn-16=3C) terminal 7 (Sn-17=4C) terminal 8 (Sn-18=5C)	(blinking) Alarm (EF3)* ¹ External Fault 3
	Terminal 5		(blinking) Alarm (EF5)* ¹ External Fault 5
	Terminal 6		(blinking) Alarm (EF6)* ¹ External Fault 6
	Terminal 7		(blinking) Alarm (EF7)* ¹ External Fault 7
	Terminal 8		(blinking) Alarm (EF8)* ¹ External Fault 8
Digital Operator communication error	Operator transmission fault 1 (Initial fault)		Alarm (CPF00)* ¹ OP comm. Error 1
	Operator transmission fault 2 (on lime fault)		Alarm (CPF01)* ¹ OP comm. Error 2
External baseblock signal input (Minor failure) { main circuit transistor } instantance shut-off	When an external base block signal is input, the motor coasts to a stop. When the external base block signal is removed, the inverter output is immediately turned on at the previously set frequency.		(blinking) Alarm (bb)* ¹ B.B.
Invalid parameter setting	When an invalid parameter is set, it is indicated on the monitor at power up or when the inverter is changed from the PRGM mode to the DRIVE mode.		Alarm (OPE01)* ¹ Set Cap. Error
			Alarm (OPE02)* ¹ Parameter Incorrect

Fault Contact output	Error causes	Action to be taken
Non Operation	●Input voltage drop	Check the main circuit DC voltage in Un-xx. If the voltage is low, adjust the input voltage.
Non Operation	●Input voltage rise	Check the main circuit DC voltage in Un-xx. If the voltage is high, adjust the input voltage.
Non Operation	<ul style="list-style-type: none"> ●Overload ●Cooling fan fault ●Ambient temperature rise ●Clogged filter 	Replace the cooling fan and clean the filter. Ambient temperature: 104 (40) or less for enclosed type 122 (45) or less for open chassis
Non Operation	●Motor current exceeded the set value because of machine fault or overload.	Check the driven machine and correct the cause of the fault or set to a higher value.
Non Operation	<ul style="list-style-type: none"> ●Insufficient power for accel/decel ●Overload ●Phase loss 	<ul style="list-style-type: none"> ●Set proper accel/decel time for smooth operation. ●For stall prevention during normal operation lighten the load or increase inverter capacity.
Non Operation	<ul style="list-style-type: none"> ●Operation sequence error ●3-wire/2-wire selection error 	<ul style="list-style-type: none"> ●Recheck the control sequence. ●Recheck system constant (Sn-15 to -18)
Non Operation	●External fault conditions set-up	●Take appropriate measurement for the cause of external fault input.
Non Operation	<ul style="list-style-type: none"> ●Transmission between the inverter and digital operator cannot be established 5 seconds after supplying power. ●Transmission between the inverter and digital operator is established once after supplying power, but later transmission fault continued for more than 2 seconds. 	<ul style="list-style-type: none"> ●Insert the operator connector again. ●Check the wiring of control circuit. ●Replace the control board or operator.
	-	-
Non Operation	●Inverter KVA setting (Sn-01) error	●Review the parameter setting range and conditions.
Non Operation	●Parameter setting range error	

Protection function		Explanation	LCD display (English)
Invalid parameter setting of Sn-15 to Sn-18.		<ul style="list-style-type: none"> ●When set value of Sn-15 to Sn-18 are not listed from smaller to the larger. ●More than two search commands of set values 61 and 62 are set. ●UP/DOWN commands are not set simultaneously. ●UP/DOWN and accel/decel prohibit commands are set simultaneously. ●More than two set values except FF are set. 	Alarm (OPE03)* ¹ I/P Fern. Incorrect
PG constant set value fault		PG constant, number of poles or PG division ratio setting fault.	Alarm (OPE04)* ¹ PG Const. Incorrect
V/F curve constant set value fault		<ul style="list-style-type: none"> ●Improper setting of V/F characteristic. (Cn-02~Cn-08) 	Alarm (OPE10)* ¹ V/F Curve Incorrect
Carrier frequency constant set value fault		<ul style="list-style-type: none"> ●Improper setting of carrier frequency. (Cn-23~Cn-25) 	Alarm (OPE11)* ¹ Carry-Freq Incorrect
Parameter read error		<ul style="list-style-type: none"> ●Parameter read error 	Alarm (Err)* ¹ Read Error
RS-485 Communication Fault	Fault 1	<ul style="list-style-type: none"> ●Communication option card Watchdog timer active and the stopping method after communicating error of Sn-08 is to continue to run (Sn-08=11xx) 	(blinking) (CPF21)* ¹ RS-485 comm. Fault 1
	Fault 2	<ul style="list-style-type: none"> ●Communication option card dual port RAM fault and the stopping method after communicating error of Sn-08 is to continue to run (Sn-08=11xx) 	(blinking) (CPF23)* ¹ RS-485 comm. Fault 2
RS-485 Communication Ready		<ul style="list-style-type: none"> ●When the inverter with communication option card (SC-C, GA-M or GA-P) does not receive correct data from master controller. 	(CALL)* ¹ RS-485 comm. Ready
PG lime broken		<ul style="list-style-type: none"> ●PG lime broken and the stopping method after PG lime broken of Sn-27 is to continue to run. 	(blinking) Alarm (PGo)* ¹ PG open
Over speed		<ul style="list-style-type: none"> ●Excessive PG speed fault and the stopping method after overspeed of Sn-28 is to continue to run. 	(blinking) Alarm (oS)* ¹ PG Over Sp.
Excessive deviation		<ul style="list-style-type: none"> ●Excessive speed deviation and the stopping method after excessive deviation of Sn-28 is to continue to run. 	(blinking) Alarm (dEu)* ¹ Sp. Deviat. Over

* 1. The display contents of LED digital operator.

Fault Contact output	Error causes	Action to be taken
Non Operation	<ul style="list-style-type: none"> ●Parameter setting incorrect. 	<ul style="list-style-type: none"> ●Review the parameter setting.
Non Operation	<ul style="list-style-type: none"> ●PG constant set value incorrect. 	<ul style="list-style-type: none"> ●Review the parameter (Cn-43 or Cn-44) setting.
Non Operation	<ul style="list-style-type: none"> ●The set values of Cn-02 to Cn-08 do not satisfy $F_{max} > F_A > F_B > F_{min}$ conditions. 	<ul style="list-style-type: none"> ●Review the parameter (Cn-02 or Cn-08) setting.
Non Operation	<ul style="list-style-type: none"> ●The set values of Cn-23 to Cn-25 do not satisfy <ul style="list-style-type: none"> - Cn-25 > 6 and Cn-24 > Cn-23 - Cn-23 > 5KHz and Cn-24 > 5KHz 	<ul style="list-style-type: none"> ●Review the parameter (Cn-23 or Cn-25) setting.
Non Operation	<ul style="list-style-type: none"> ●EEPROM internal data did not match when initializing the constant 	<ul style="list-style-type: none"> ●Turn off power, then turn on again. If error is persistent, replace the control board.
Non Operation	<ul style="list-style-type: none"> ●RS-485 communication option card fault. ●External noise ●Excess vibration or shock. 	<ul style="list-style-type: none"> ●Turn off power, then turn on again. If error is persistent, replace the option card.
Non Operation		
Non Operation	<ul style="list-style-type: none"> ●Poor connection. ●Defective communication software (in master controller). 	<ul style="list-style-type: none"> ●Check for communication cable between communication option card and master controller (PLC). ●Check for communication software.
Non Operation	<ul style="list-style-type: none"> ●The PG Wiring is not properly connected or open circuit. 	<ul style="list-style-type: none"> ●Check the PG wiring.
Non Operation	<ul style="list-style-type: none"> ●Improper setting of ASR parameter or overspeed protection level (Cn-52) 	<ul style="list-style-type: none"> ●Check the parameter of ASR and the protection level.
Non Operation	<ul style="list-style-type: none"> ●Improper setting of ASR parameter or speed deviation level (Cn-51) 	<ul style="list-style-type: none"> ●Check the parameter of ASR and the speed deviation level.

4. APPENDIX

A. SENSORLESS VECTOR CONTROL

The 7200GAS standard with selectable control modes, V/F control mode (GP mode), sensorless vector control mode (SL mode), PID with Auto Energy Saving control mode (PID mode) and V/F+PG closed loop control mode (PG mode). When the Sensorless vector control mode is selected(Sn-13=0001), be sure to make the inverter capacity and the motor rating are suitably matched. The AUTOTUNE feature can be used to identify and store the important motor parameters in the first time sensorless vector operation after installation, and when switching to one of the other three control mode, then switched back to the sensorless vector control mode, the AUTOTUNE feature has to be used to identify and store the motor parameters once again.

(a) Constants related to Sensorless Vector Control

Function	Parameter	Name and Descriptions	LCD Display (English)	Setting Unit	Setting Range	Factory Setting	Valid Access Levels			
							GP	SL	PID	PG
V/F curve	Sn-02	Fixed to OF for the SL mode	Ref. to Sn-02 descriptions	-	0F	0F				
Over torque Detection	Sn-07	Used the 4th digit to select overtorque detection by current or torque	Ref. to Sn-07 descriptions	-	-	0000	1	2	1	1
Operation mode selection	Sn-09	1 Analog output (terminal 21 - 22) can be selected as inverter output torque signal 2 Slip compensation during regenerating selection	Ref. to Sn-05,Sn-09 descriptions	-	-	0000	1	2	3	
Analog Input Selection	Sn-19	Sn-19=OB, the analog input (terminal 16) function as torque limit	Ref. to Sn-19 descriptions	-	00-0F	00				
Auto tuning	Sn-29	Motor parameters auto tuning selection	Sn-29=0 Auto tuning invalid	-	-	0				
Motor slip	Bn-08*	Rated slip of motor	Bn-08=1.7HZ Motor Rated Slip	0.1HZ	0.0~20.0HZ	1.7HZ	1	2		
-	Cn-09*	Motor Rated current	Cn-09=031.0A Motor Rated I	0.1A	-	31A				
-	Cn-31*	Motor terminal resistance (R1)	Cn-31=0.308 Motor Line R	0.001	0~65.535	0.308				
-	Cn-32*	Motor Leakage Inductance (Ls)	Cn-32=005.54mH Equivalent Leakage L	0.1mH	0.00~200.00mH	5.54mH	1	2	1	1
-	Cn-33	Torque limiter	Cn-33=150% Torque Limiter	1%	0~200%	150%	1	2	1	1
-	Cn-34*	Motor no load current	Cn-34=030% Motor No-Load I	1%	0~99%	30%				
-	Cn-35	Slip compensation delay time	Cn-35=0.2S Slip Filter	0.1S	0.0~25.5S	0.2S	1	2		

● The Induction Motor Y-equivalent model.

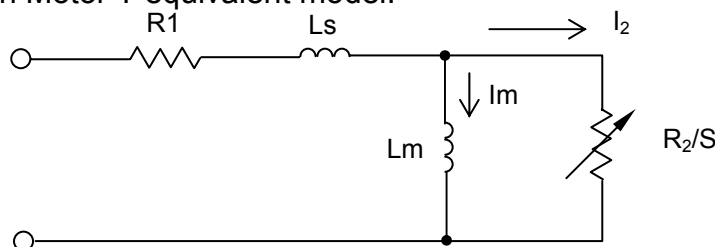

(b) The Sequence of Motor Parameter Autotuning

- (1) Disconnect the motor load and make sure that the wiring between the inverter and the motor is suitable. Check the class difference of inverter capacity and motor rating is less than 2 class or equal.
- (2) Switch to PRGM operation mode by pressing the digital operator

PRGM
DRIVE

 key.
- (3) Key in motor rated voltage data to Cn-13, motor rated slip to bn-08 and motor rated current to Cn-09 according to the motor's nameplate.
- (4) Enable the autotuning function by setting Sn-29=1.
- (5) Switch to DRIVE operation mode by pressing the

PRGM
DRIVE

 key, than run the inverter by pressing the

RUN

 key
- (6) The inverter system immediately enters into the autotuning operation, while complete(normally, about 20 seconds), the inverter return to stopped condition. The value of motor parameter will be automatically stored in Cn-31.
- (7) Switch to normal operation mode(set Sn-29=0), then run the inverter by pressing the

RUN







 key in the DRIVE operation mode.

(c) The Operation and Adjustments of Sensorless Vector Control.

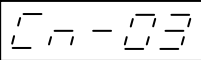
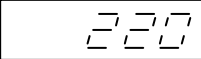
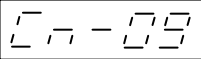
- (1) Adjust the setting bn-08, if the speed accuracy needs to improve. When the actual speed is lower than the setting speed, increase the set value and when the speed is higher, decrease the set value.
- (2) If the motor speed is not stable or the load inertia is too large, increase the slip compensation delay time (Cn-35) setting. Decrease the set value to improve the speed response when the load inertia is smaller.
- (3) If sufficient torque cannot be obtained at a low speed, change the V/F pattern setting of Cn-02 to Cn-08 to high starting V/F or increase the auto torque boost gain (bn-07).

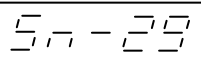
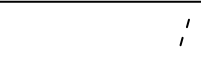
[Note] The autotuning feature is an off-line autotuning functions, used the AUTOTUNING function to identity and store the motor parameter only in the first time sensorless vector operation after installation, the inverter will adjust the related motor parameters to an optimum value during running automatically.

(d) The Operation Sequence and Display of Motor Parameter Autotuning.

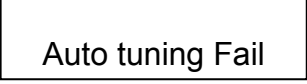
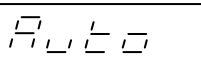
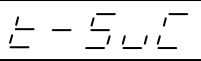
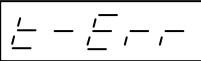
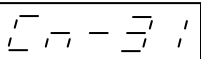
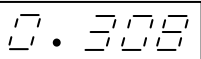
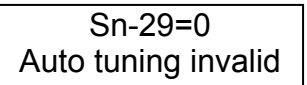
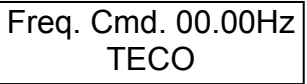
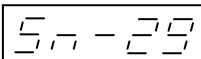
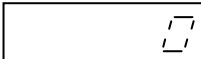
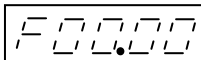
Operation Sequence	LCD Display (English)	LED Display
1 Key in motor rated voltage data to Cn-03 (example: 220V)	Cn-03=220V Max. Voltage	 
2 Key in motor rated current to Cn-09 (example: 31A)	Cn-09=031A Motor Rated I	 
3 Enable the Autotuning function by setting Sn-29=1	Sn-29=1 Auto tuning Valid	 
4 Switch to DRIVE operation mode by pressing the  key, then run the inverter by pressing the  key Autotuning operation completed. (success) Autotuning operation fail.	  	  
5 To read the motor terminal resistance. (example: 0.308)	Cn-31=0.308 Motor Line R	 
6 Switch to normal operation by setting Sn-29=0 Selected DRIVE mode	 	  

B. AUTO ENERGY-SAVING CONTROL IN PID CONTROL MODE

When the PID control mode is selected (Sn-13=0010), the Auto Energy Saving (AES) function adjust an optimum output voltage to minimize the inverter output current automatically according to the load. The output power can be saved, the saved value varies according to the load ratio. Little energy-saving effect is obtained with the load ratio exceeding 70%. As the load becomes lighter, the effect becomes larger.

<a> Constants rebted to Auto Energy-Saving Control in PID Control Mode.

The table below shows the constants need in the auto energy-saving mode. To change any of the On- parameters, it is necessary to set Sn-03 to 1010, and set Sn-03 to 0000 after changed On- parameters for safe.

Function	Parameter	Name and Descriptions	LCD Display (English)	Setting Unit	Setting Range	Factory Setting	Valid Access Levels			
							GP	SL	PID	PG
-	Sn-08	-0--: Energy Saving function ineffective (V/F) -1--: Energy Saving function effective	Sn-08=0000 Option/IW Eg. Saving	-	-	0000	1	1	2	3
Energy-Saving Voltage Limit	Cn-45	Energy Saving Voltage Upper Limit(60HZ)	Cn-45=120% Hi-sp.d. Sav. V-Upper	1%	0~120%	120%			1	2
	Cn-46	Energy Saving Voltage Upper Limit(6HZ)	Cn-46=16% Lo-sp.d. Sav. V- Upper	1%	0~25%	16%			1	2
	Cn-47	Energy Saving Voltage Lower Limit(60HZ)	Cn-47=050% Hi-sp.d. Sav. V-Lower	1%	0~100%	50%			1	2
	Cn-48	Energy Saving Voltage Lower Limit(6HZ)	Cn-48=12% Lo-sp.d. Sav. V- Lower	1%	0~25%	12%			1	2
Energy-Saving Tuning Operation	Cn-49	Tuning operation voltage limit	Cn-49=00% Sav. Tuning V-Limit	1%	0~20%	0%			1	2
	Cn-50	Tuning operation control cycle	Cn-50=01.0s Sav. Tuning period	0.1s	0.1~10.0s	1.0s			1	2
	Cn-51	Tuning operation voltage step(100% output voltage)	Cn-51=00.5% Sav. Tuning Gain 1	0.1%	0.1~10.0%	0.5%			1	2
	Cn-52	Tuning operation voltage step(5% output voltage)	Cn-52=00.2% Sav. Tuning Gain 2	0.1%	0.1~10.0%	0.2%			1	2
Energy-Saving Motor Constants *1	Cn-53	Not used	Cn-53= Reserved	0	-	-				
	Cn-54	Not used	Cn-54= Reserved	0	-	-				
	Cn-55	Not used	Cn-55= Reserved	0	-	-				
	Cn-56	Not used	Cn-56= Reserved	0	-	-				
	Cn-57	Not used	Cn-57= Reserved	0	-	-				
Energy-Saving Coefficient K2	Cn-58	Energy-Saving Coefficient K2(60HZ)	Cn-58=115.74*1 Eng. Saving Coeff.	0.01	0.00~655.35	115.74 *1				
	Cn-59	Energy-Saving Coefficient reduction ratio(6HZ)	Cn-59=100% K2 Reduce Ratio	1%	50~100%	100%				
	Cn-60	Motor Code	Cn-60=29*2 440V 25HP	-	00~FF	29 *2				
Energy-Saving Power Detection	On-15	Power detection filter changing width	On-15=010% Power-Det. Dead Zone	1%	0~100%	10%				
	On-16	Power detection filter Time constant	On-16=020 Power-Det. Time Const	1 (7ms)	1~255	20 (140ms)				

- *1. Difference depending on the setting of Cn-60.
- *2. The same value as Sn-01 is set by initializing.

(1) Energy-saving voltage limit (Cn-45 to Cn-48)

- The upper and lower limits of output voltage are set. If the voltage reference value calculated in the energy-saving mode exceeds the upper or lower limit value, this upper or lower limit value is output as voltage reference value.
- The upper limit value is set in order to prevent over excitation at low frequency and the lower limit value is set in order to prevent stalling at a light load. Limit voltage values obtained at 6Hz and 60Hz are set: for any limit value other than at 6Hz and 60Hz, the values calculated by linear interpolation of these values. Setting is made in the units of % of rated voltage.

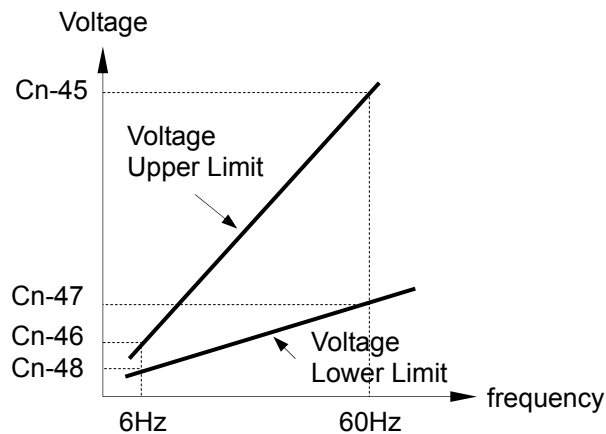

(2) Energy-saving tuning operation (Cn-49 to Cn-52)

- In the energy-saving mode (Sn-09 = X1XX) the optimum voltage is calculated according to load power and the voltage is supplied to the load. However, since the setting motor constants are different depending on temperature variation or use of other manufactures'-motors, the optimum voltage is not always output. At tuning operation, operation is controlled so that the optimum operating status can be obtained by fine adjustment of voltage.

(a) Tuning Operation voltage Limit (Cn-49)

- Limits the range where voltage is controlled by tuning operation. Setting is made in the units of % of rated voltage. By setting this value to 0, tuning operation is not performed.

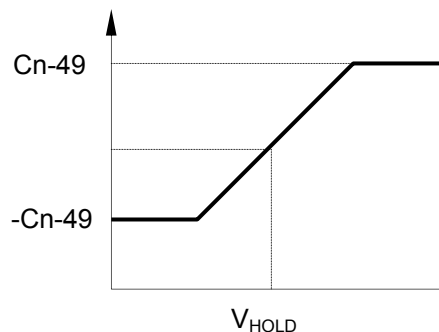

(b) Tuning Operation Control Cycle (Cn-50)

- Sets the control cycle of tuning operation.

(c) Tuning Operation voltage Step (Cn-51, 52)

- Sets voltage variation width of one tuning operation cycle. Setting is made in the units of % of rated voltage. By increasing this value, rotation speed variation becomes larger. This voltage variation width is set at tuning starting voltage 100% and 5%. With the other voltage value, voltage variation width obtained by linear interpolation is set.

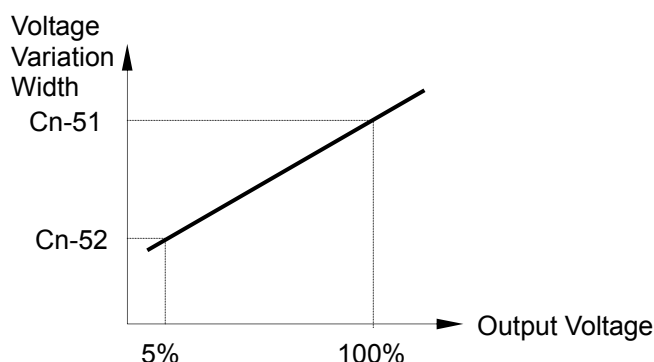

(3) Energy-saving coefficient K2 (Cn-58)

- Voltage at which the motor efficient will be the maximum is calculated by using this coefficient at operation in the energy-saving mode, and the calculated value is to be voltage reference. This value is already set to the value of a TECO motor as the initial value. By increasing the energy-saving coefficient, output voltage becomes larger.

(4) Energy-saving coefficient reduction ratio (Cn-59)

- In order to prevent over excitation in the low frequency area, this constant reduces output voltage at low frequency. Set in the reduction ratio at 6Hz. According, to this value, output voltage is reduced with the reduction ratio (Cn-59) when output voltage of 15Hz or less is 6Hz or with the reduction ratio obtained by linear interpolation of reduction ratio (100%) at 15Hz.

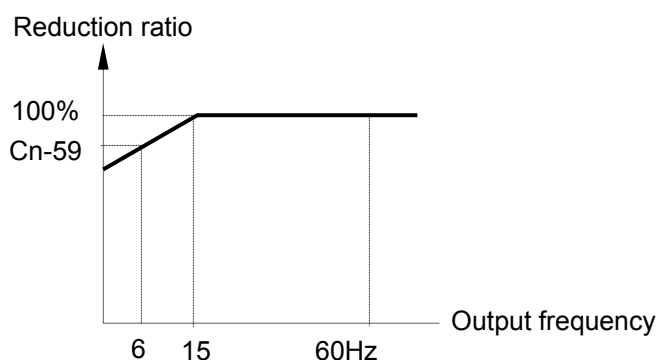

(5) Motor code (Cn-60)

- By setting this code, energy-saving coefficient is set to Cn-58 when a TECO motor is used. This motor code is the same as that used for motor constant setting (Sn-01) By setting the capacity and initializing by Sn-01, the same code is written to Cn-60. Therefore, when the inverter and motor has the same capacity, setting is not needed. When exclusive use motor or other manufacturer's motor is used and its motor constant is not known or when the inverter and motor has the different capacity, try to set the mother code corresponding to the motor voltage and capacity to Cn-60. The motor codes are shown in the table below.

(220V class)

Cn-60	Motor Capacity	Cn-58 Initial value
00	1/2	288.20
01	1	223.70
02	2	169.34
03	3	156.80
04	5	122.90
05	7.5	94.75
06	10	72.69
07	15	70.44
08	20	63.13
09	25	57.87
0A	30	51.79
0B	40	46.27
0C	50	38.16
0D	60	35.78
0E	75	31.35
0F	100	23.10

(440V class)

Cn-60	Motor Capacity	Cn-58 Initial value
20	1/2	576.40
21	1	447.40
22	2	388.80
23	3	313.60
24	5	245.60
25	7.5	189.50
26	10	145.38
27	15	140.88
28	20	126.26
29	25	115.74
2A	30	103.58
2B	40	92.54
2C	50	76.32
2D	60	71.56
2E	75	67.20
2F	100	46.20
30	125	41.22
31	150	36.23
32	175	33.88
33	215	30.13
34	250	29.20
35	300	27.13
36	400	21.76

 Energy-Saving operation procedures

- (1) Enter the energy-saving mode by setting the third digit of operation mode selection 5 (Sn-09) to 1. (The energy-saving mode is already set at prior to shipping.)
- (2) Set Cn-60 to the motor code (refer to page) which is determined by the motor capacity and voltage.
- (3) Set operation frequency.
- (4) Input the run command
The motor accelerates up to the set frequency (bn-01), when it reaches to the set value, the energy-saving mode is entered and operation is performed at voltage according to the load.

<c> Verification of Energy-saving Power

Energy-saving power can be verified by comparing power in the V/f control mode operation (Sn-09 third digit to 0) with power in the energy-saving mode operation (Sn-08 third digit to 1). Power can be monitored by Un-06.

Energy saved value varies according to the load ratio. Little energy-saving effect is obtained with the load ratio exceeding 70%. As the load becomes lighter, the effect becomes larger.

<d> Adjustment

Since the constants used in the energy-saving mode are already set to the optimum values as initial values, adjustment is not needed in the normal status. However, when the motor characteristics are much different from those of the TECO standard motors or if a fault occurs because of improper constant setting, perform the following, adjustment.

Adjustment at fault Occurrence

Fault	Corrective Action
Power does not change in the energy-saving mode.	Does setting frequency exceed 100Hz? If it does, the energy-saving mode is released.
Power variation is very small in the energy-saving mode.	Is the load ratio excessively large? When the load ratio is excessively large, energy saved value becomes larger as the load becomes lighter.
Hunting at a light load	Increase the time constant (On-16) of power detecting filter.
Current increases to cause OL1 or OL2 although within rated load torque (Especially at low frequency).	Decrease the value (Cn-46) of energy-saving voltage upper limit at 6Hz. Or decrease the energy-saving coefficient reduction ratio (Cn-59).
When the energy-saving mode is entered after completion of acceleration, the motor stalls to a stop (Especially at a light load).	Increase the lower (Cn-47 or Cn-48).
Revolutions change periodically and its cycle is almost equal to Cn-50 set value.	Decrease search operation voltage stop (Cn-51 or Cn-52)

C. PID CONTROL IN PID CONTROL MODE

When the PID control mode is selected (*Sn-13=0010), there are standard with Auto Energy Saving function (AES, as appendix B shown) and PID control function.

The PID control function is a control system that matches a feedback value (i.e. a detected value) to the set target value. Combining proportional (P), integral (I), and derivative (D) control makes control possible even for a mechanical system with dead time. This section explains the PID control applications and operations, along with the constant settings and tuning procedure.

<a> Constants related to PID Control Mode

Function	Parameter NO	Name	LCD Display (English)	Setting Unit	Setting Range	Factory Setting	Valid Access Levels			
							GP	SL	PID	PG
Setting of PID Control aimed value *1	An-01	Setting of aimed value 1 (Frequency command 1)	An-01 = 060.00Hz Frequency command 1	0.01Hz	0.00~400.00Hz	60.00Hz				
	An-02	Setting of aimed value 2 (Frequency command 2)	An-02 = 000.00Hz Frequency command 2	0.01Hz	0.00~400.00Hz	0.00Hz				
	An-03	Setting of aimed value 3 (Frequency command 3)	An-03 = 000.00Hz Frequency command 3	0.01Hz	0.00~400.00Hz	0.00Hz				
	An-04	Setting of aimed value 4 (Frequency command 4)	An-04 = 000.00Hz Frequency command 4	0.01Hz	0.00~400.00Hz	0.00Hz				
	An-09	Setting of aimed value 5 (Frequency command 5)	An-09 = 006.00Hz Jog command	0.01Hz	0.00~400.00Hz	6.00Hz				
Setting of PID Control Constant	bn-13	Setting of detected value adjustment (PID Detection Gain)	bn-13 = 01.00 PID Gain	0.01	0.01~10.00	1.00				
	bn-14	Setting of proportional Gain (P)	bn-14 = 01.0 PID P-Gain	0.1	0.0~10.0	1.0				
	bn-15	Setting of integral time (I)	bn-15 = 010.0S PID I-Time	0.1S	0.0~100.0S	10.0S				
	bn-16	Setting of differential time (D)	bn-16 = 0.00S PID D-Time	0.01S	0.00~1.00S	0.00S				
	bn-17	PID offset adjustment (PID Bias)	bn-17 = 000% PID Bias	1%	0~109%	0%				
	Cn-43	PID integral upper Bound	Cn-43 = 100% PID I-Upper	1%	0~109%	100%			1	*2
	Cn-44	PID primary delay time constant	Cn-44 = 0.0S PID Filter	0.1S	0.0~2.5S	0.0S			1	*2
Integral value reset	Sn-15 ~ Sn-18	Integral value reset by external contact signal	-	-	-	-				
PID Control Cancel	Sn-15 ~ Sn-18	PID Control Canceled by external contact signal	-	-	-	-				
PID Control selection	Sn-19	PID Control mode is entered by setting Sn-19=09	-	-	-	-				
Control mode selection	Sn-13	Control mode selection	Sn-13=0010 PID Mode	-	-	-				

*1. The unit and setting range of An- can be changed according to the setting of the operator display mode (Cn-20).

*2. Cn-43, Cn-44 have different function in the PG control mode (Ref. To appendix D).

 How to input PID control signals

For setting of aimed values, the multi-function analog input (control terminal 16) or Constant An-01 ~ 04 can be selected. The detected feedback value can be input from control terminal 13 (0 ~ 10V voltage signal) or Control terminal 14. (4 ~ 20mA current signal), as shown below.

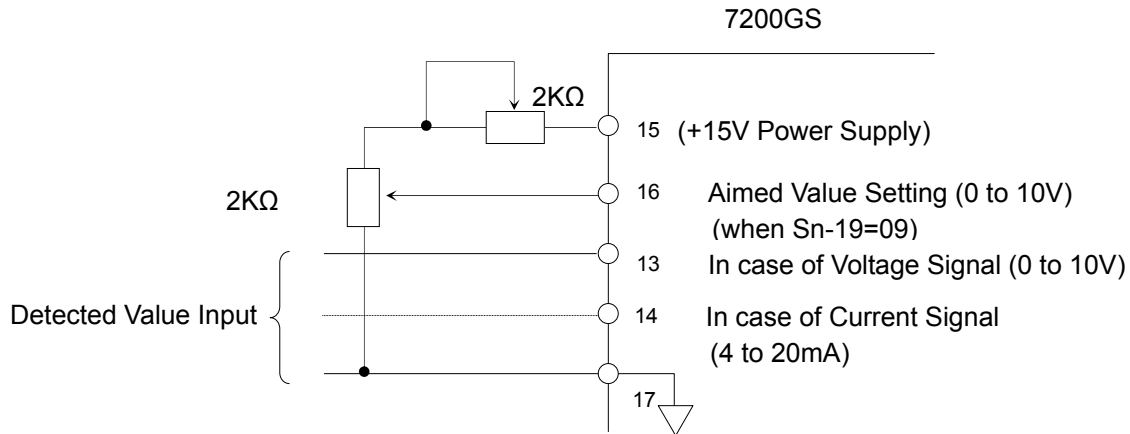

- (1) When only control terminal 16 is used: set Sn-04 = XXX0.
- (2) When constant An for frequency reference is used:
Set the aimed values to An-01 to 04 and 09 The aimed value to be used can be selected by combination of multi-step speed reference 1 or 2 and jog command (setting by constant Sn-15 ~ 18), as the table below shown.

Selection of Aimed Values

Jog Command	Multi-step Speed 2	Multi-step Speed 1	Value to be Selected
OFF	OFF	OFF	An-01
OFF	OFF	ON	An-02
OFF	ON	OFF	An-03
OFF	ON	ON	An-04
ON	-	-	An-09

* : When Sn-04 = XXX0 is set, 16 terminal signal is used instead of An-01. An-01 is used when Sn-04 = XXX1.

<c> How to adjust

The PID control function is a control system that matches a feedback value (ie., a detected value) to the aimed value. Combining P (Proportional, bn-14), I (Integral, bn-15), and D (Derivated, bn-16) makes control possible even for a mechanical system with dead time. The PID control function, using different detected sensors, can be used for speed, pressure, flow or temperature etc. applications.

(1) PID control Block Diagram and Step Porpoise

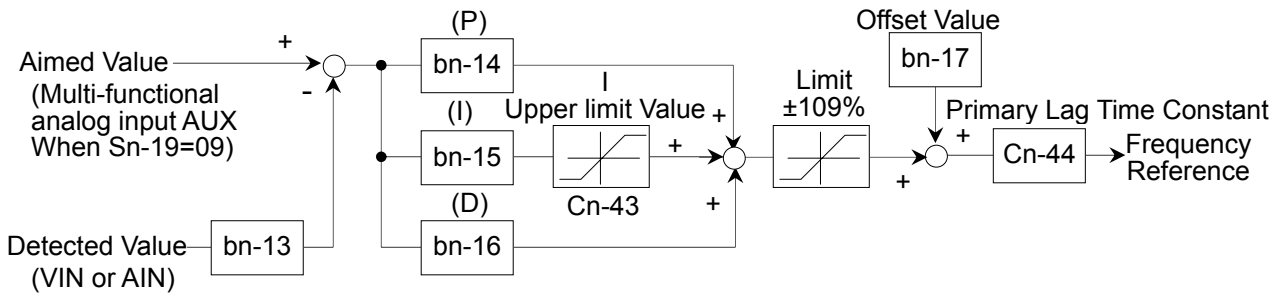

Fig 11 Block Diagram of PID Control Section

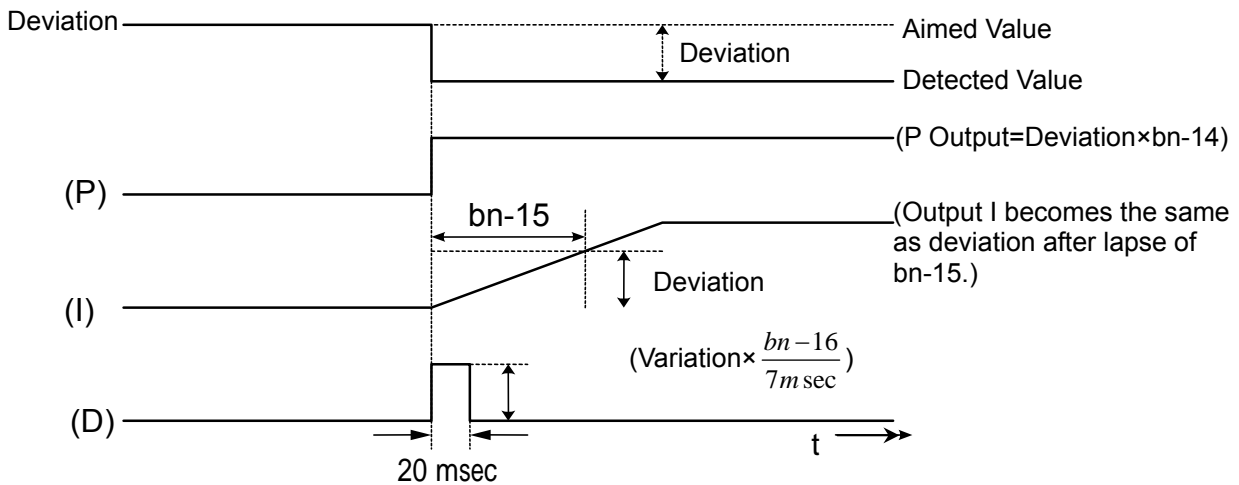

Fig 12 Response when Deviation is of Step Form

- Deviation = Aimed value – detected value × bn-13
- P output = Deviation × bn-14
- I output = Integration of deviation, the additional value obtained at every 7msec can be calculated by the following equation:

$$\left[\text{Deviation} \times \frac{7m \text{ sec}}{bn-15 \text{ set value}} \right]$$

- D output = the output is obtained by multiplying the difference between the value before 7msec of deviation and the current value by gain of $(\frac{bn-16 \text{ set value}}{7m \text{ sec}})$.
- The PID final outputs are all added.

(2) PID control operations.

In order to distinguish the separate PID control operations. The figure below shown the changes in the control input when the deviation between the target value and the feed back is held constant.

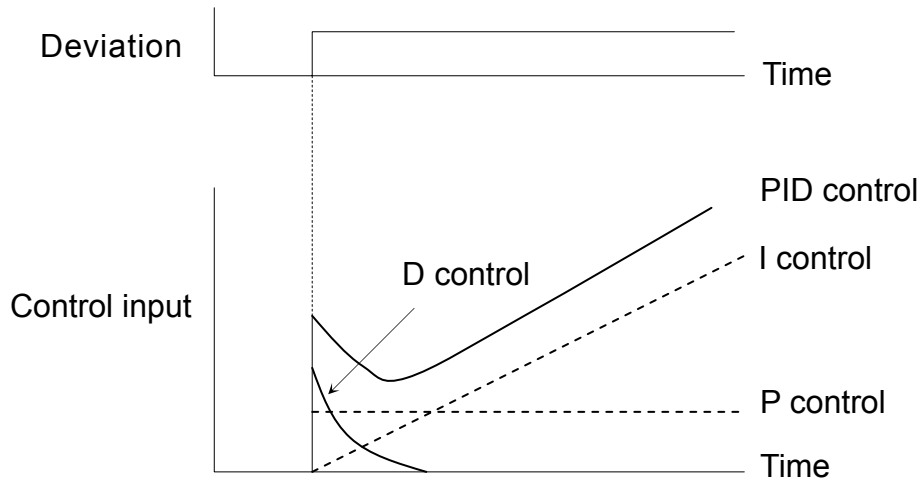

Fig. 13 PID Control Operations

- P Control: A control input proportional to the deviation is output. The deviation cannot be zeroed by P control alone.
- I Control: A control input which is an integral of the deviation is output. This is effective for matching the feedback to the target value. Sudden changes, however, cannot be followed.
- D Control: A control input which is an integral of the deviation is output. Quick response to sudden changes is possible.
- PID Control: Optimum control is achieved by combining the best features of P, I, and D control.

(3) Adjusting PID constant

Refer to page, the block diagram of PID control selection, using the following procedure to activate PID control and then adjust it while monitoring the response.

- (I) Enable PID control function (Setting Sn-19 = 09, and if any constant Sn-15 ~ 18 setting value is 66, then none of control terminal 5 ~ 8 can be closed).
 - (II) Increase the proportional gain P (bn-14) as far as possible without creating oscillation.
 - (III) Reduce in integral time I (bn-15) as far as possible without creating oscillation.
 - (IV) Increase the differential time D (bn-16) as far as possible without creating oscillation.
- First set the individual PID control constants, and then make fine adjustments.

●Reducing Overshooting

If overshooting occurs, shorten the derivative time D (bn-16) and lengthen the integral time I (bn-15)

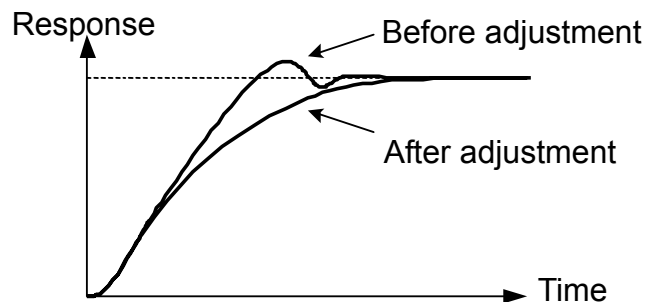

●Rapidly Stabilizing Control Status

To rapidly stabilize the control conditions even when overshooting occurs, shorten the integral time I (bn-15) and lengthen the derivative time D (bn-16)

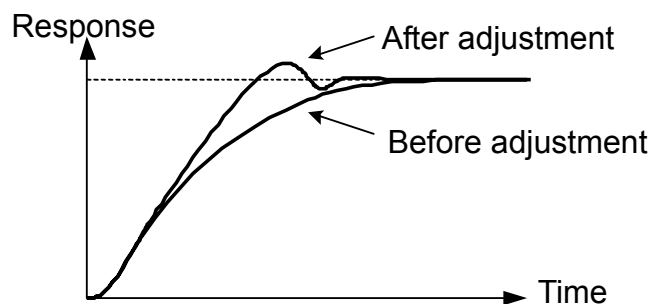

- Reducing Long-cycle Oscillation

If oscillation occurs with a longer cycle than the integral time I (bn-15) setting it means that integral operation is strong. The oscillation will be reduced as the integral time I is lengthened.

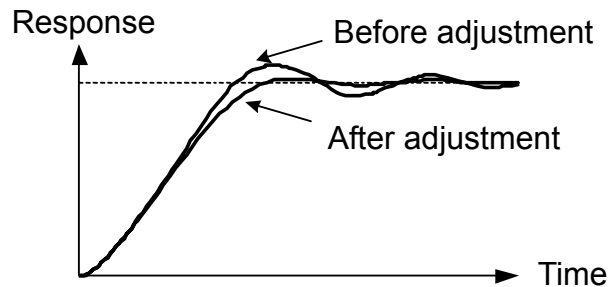

- Reducing Short-cycle Oscillation

If the oscillation cycle is short and oscillation occurs with a cycle approximately the same as the derivative time D (bn-16) setting, it means that the derivative operation is strong. The oscillation will be reduced as the derivative time (D) is shortened.

If oscillation cannot be reduced even by setting the derivative time (D) to "0.00" (no derivative control), then either lower the proportional gain P (bn-14) or raise the PID's primary delay time constant (Cn-44).

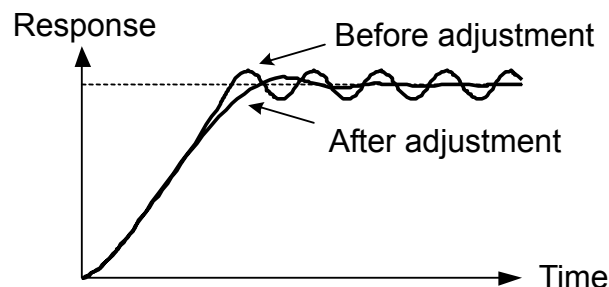

D. PG FEEDBACK CONTROL

When the PG control mode is selected (Sn-13=11) and mounted the PG speed control option card FB-C on the control board of the inverter unit the 7200GAS can utilize a motor PG (pulse generator) which provides a means of speed feedback to compensate for speed fluctuations due to slip, to improve the speed accuracy.

(a) FB-C Interconnection Diagram

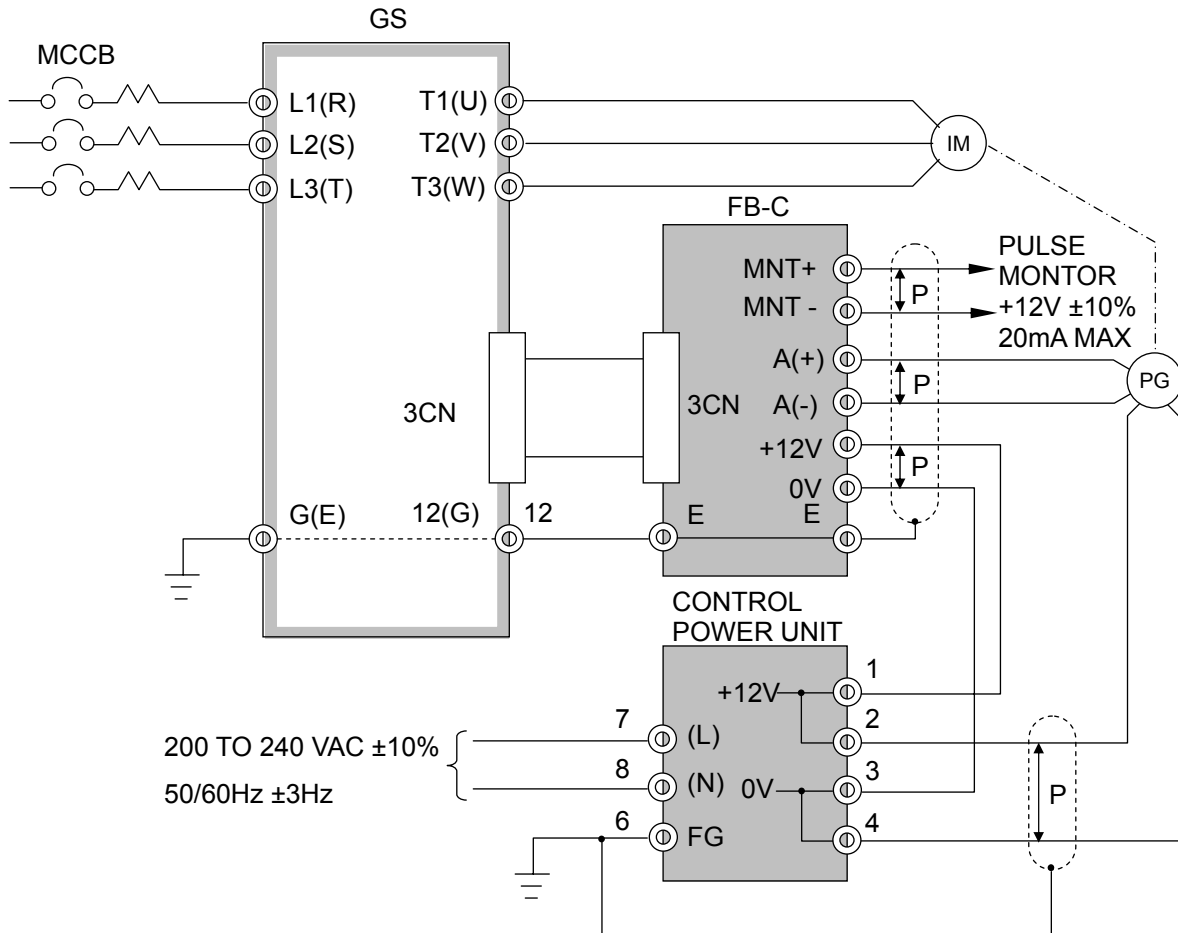

Note :  indicates twisted-pair shielded leads.

Fig. 14 FB-C Interconnection Diagram

[Note 1] The FB-C Cannot be connected to the inverter together with the following option cards:

- Communication card : SI-M
- Analog monitor card : AO-12
- Pulse monitor card : PM-C
- Digital monitor card : DO=08

[Note 2] The PG interface only allows the open-collector interface or complementary interface.

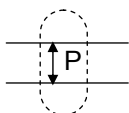
[Note 3] Please refer to 「FB-C Instruction Manual」 for details.

(b) Constants related to PG Control

Function	Parameter NO	Name	LCD Display (English)	Setting Unit	Setting Range	Factory Setting	Valid Access Levels			
							GP	SL	PID	PG
Multi-Function Selection	Sn-15 ~ Sn-18	Sn-15~18=0D: Speed control valid/invalid control Sn-15~18=0E: Integral value is reset in speed control	Ref. to Sn-15~18 descriptions	-	-	-				
FB-C Function Selection	Sn-27 ~ Sn-28	Ref. To Sn-27, Sn-28 descriptions	-	-	-	-	1	2	3	4
Multi-Function Analog Output	bn-11	bn-11=12: Amount of speed feedback bn-12=13: Amount of control compensation	Ref. to bn-11 descriptions	-			1	1	1	2
Monitoring parameter	Un-12	Amount of speed feedback at PG control mode	Un-12=100.0% Speed Feedback	0.1%	-	-		1	2	3
	Un-13	Amount of speed control compensation	Un-13=10.0% Speed Comp.	0.1	-	-				
Speed Control parameters	Cn-43	PG constant	Cn-43=000.0 P/R PG Parameter	0.1P/R	0.0~3000.0P/R	0.0P/R			1	2
	Cn-44	Number of motor poles	Cn-44=0.4 P Motor Pole	2P	0~32P	4P			1	2
	Cn-45	ASR Proportional gain 1	Cn-45=0.00 ASR Gain 1	0.01	0.00~2.55	0.00			1	2
	Cn-46	ASR integral time 1	Cn-46=01.0s ASR Intgl. Time 1	0.1s	0.1~10.0s	1.0s			1	2
	Cn-47	ASR Proportional gain 2	Cn-47=0.02 ASR Gain 2	0.01	0.00~2.55	0.02			1	2
	Cn-48	ASR integral time 2	Cn-48=01.0s ASR Intgl. Time 2	0.1s	0.1~10.0s	1.0s			1	2
	Cn-49	ASR Upper bound	Cn-49=05.0% ASR Up. Bound	0.1%	0.1~10.0%	5.0%			1	2
	Cn-50	ASR Lower bound	Cn-50=00.1% ASR Low. Bound	0.1%	0.1~10.0%	0.1%			1	2
	Cn-51	Excessive speed deviation detection level	Cn-51=10% Sp. Deviat. Det. Level	1%	1~50%	10%			1	2
	Cn-52	Over speed detection level	Cn-52=110% Over Sp. Det. Level	1%	1~120%	110%			1	2

(1) PG Constant (Cn-43)

This constant determines the number of output pulses per revolution of the pulse generator (PG). When PG is connected to motor shaft via a mechanism such as a gear, speed ratio may occur. In this case, multiply the ratio by the constant. If 0 is set, speed detection and speed control are not executed.

Where PG constant: 900 P / R,

$$\text{Gear ratio: } \frac{1}{8}$$

Set $112.5 (900 \times \frac{1}{8})$ to Cn-43.

(2) Number of Motor Poles (Cn-44)

The number of motor poles is set. If the set value of Cn-43 or Cn-44 does not satisfy the following condition, a setting error occurs and **PE016** displayed. Set values are checked when the power supply is turned ON or when the program mode is changed to the drive mode.

$$\frac{2 \times Cn-43 \times Cn-44}{Cn-44} \leq 65535$$

(3) ASR Proportional Gain 1 (Cn-45)

ASR proportional gain at 0% output frequency is set.

(4) ASR Integral Time 1 (Cn-46)

ASR integral time at 0% output frequency is set.

(5) ASR Proportional Gain 2 (Cn-47)

ASR proportional gain at 100% output frequency is set.

(6) ASR Integral Time 2 (Cn-48)

ASR integral time at 100% output frequency is set.

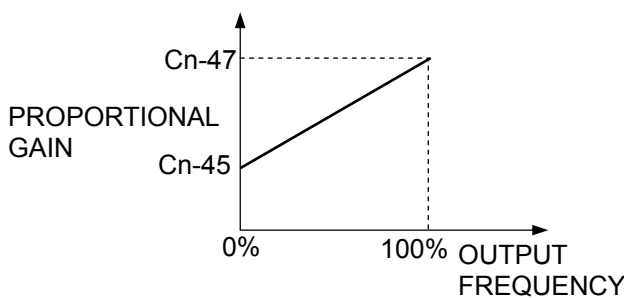

Fig. 15 Relation between Output Frequency and Proportional Gain

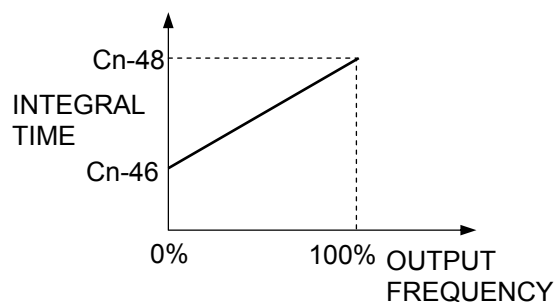

Fig. 16 Relation between Output Frequency and Integral Time

(7) ASR Upper Bound (Cn-49)

ASR Upper Bound is set in units of 1% ratio for the maximum frequency.

(8) ASR Lower Bound Negative Limit (Cn-50)

ASR Lower Bound is set in units of 1% ratio for the maximum frequency.

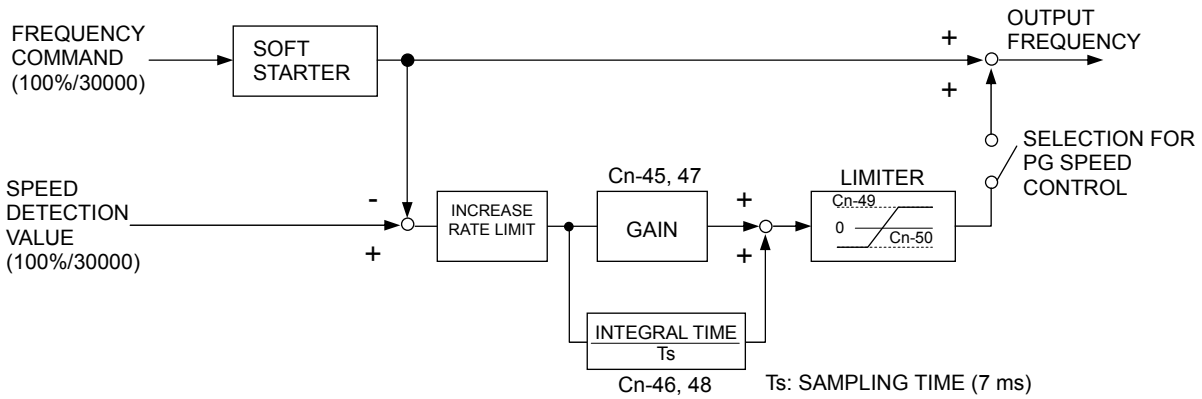

Fig. 17 ASR Block Diagram when PG Speed Control Card is Connected

(9) Excessive Speed Deviation Detection Level (Cn-51)

The level to detect excessive speed deviation is set in units of 1% ratio for the maximum frequency.

(10) Excessive Speed Detection Level (Cn-52)

The level to detect excessive speed is set in units of 1% ratio for the maximum frequency.

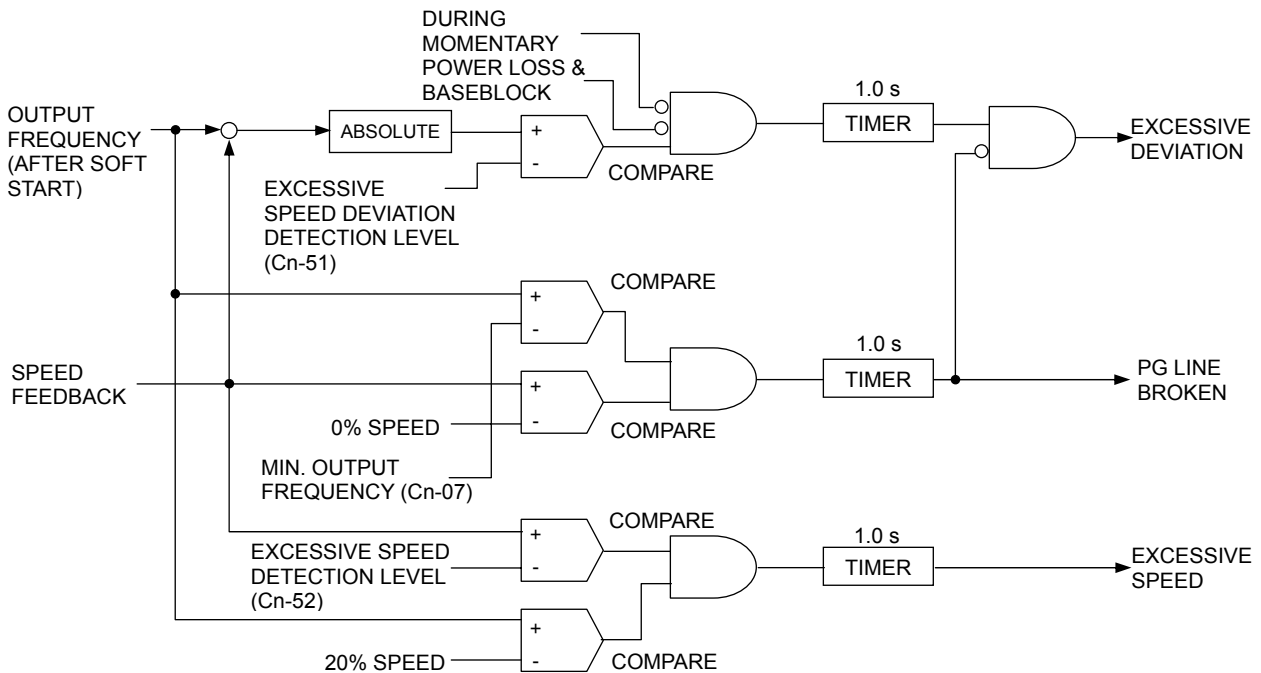
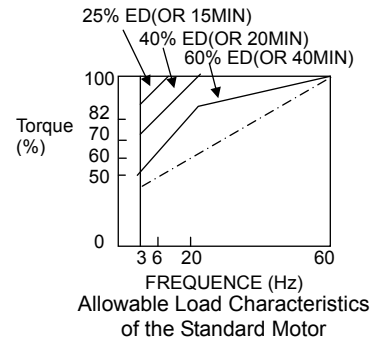

Fig. 18 Fault Detection Block Diagram

E. NOTES ON APPLICATION OF MOTORS

Motor Application Notes for Standard Motors

A standard motor driven by the inverter generates slightly less power than it does when it is driven with commercial power supply. Also, the cooling effect deteriorates in low speed range so that the motor temperature rise increases. Reduce load torque in the low speed range. Allowable load characteristics of the standard motor are shown in the figure. If 100% continuous torque is required in the low speed range, use an inverter duty motor.



High speed operation

When the motor is used above 60Hz, motor mechanical design should be verified. Contact your motor manufacturer.

Torque characteristics

Motor torque characteristics vary when the motor is driven by an inverter instead of commercial power supply. Check the load torque characteristics of the machine to be connected.

Vibrations

Because of the high carrier modulation technique for PWM control, the 7200GAS series reduces motor vibration to a level equal to running with a commercial power supply. Larger vibrations may occur under the following conditions:

- (1) Response at resonant frequency of the mechanical system.
Special care is required if a machine which has previously been driven at a constant speed, is to be driven at varying speeds. Installation of anti-vibration rubber padding under the motor base and frequency jump control are recommended.
- (2) Rotator residual imbalance
Special care is required for operation at 60Hz or higher frequencies.

Noise

Inverter operation is as quiet as operation with commercial power supply. At above rated speed (60Hz), noise may increase by motor cooling fan.

Application to Special Purpose Motors

Motors with Brakes	Use brake-equipped motors with an independent power supply. Connect the brake power supply to the inverter primary side. When the brake Operates (the motor stops) it turns the inverter output OFF. Some types of brakes may make abnormal sounds in low speed range.
Pole Change Motors	Select the inverter with a capacity exceeding the rated current of each pole. Pole change should be made only after the motor stops. If a pole is changed while the motor is rotating, the regenerative overvoltage or overcurrent protection circuit is activated and the motor coasts to a stop.
Submersible Motors	Since the rated current of underwater motors is large compared with general purpose motors, select an inverter with a larger capacity. If the wire length between the inverter and the motor is large, use cables with sufficiently large diameter.
Explosion-proof Motors	Explosion-proof motors which are applied to inverters must be currently approved as explosion-proof equipment. The inverter is not explosion-proof and should not be located where explosive gases exist.
Geared Motors	Lubrication method and continuous rotation limit differ with manufacturers. When oil lubrication is employed, continuous operation only in low speed range may cause burnout. Before operating the motor at more than 60Hz, you should consult the motor manufacturer.
Single-phase Motors	Single-phase motors are not suitable for variable speed operation with an inverter. If the inverter is applied to a motor using a capacitor stack, a high harmonic current flows and the capacitor may be damaged. For split-phase start motors and repulsion start motors, the internal centrifugal switch will not be actuated and the starting coil may be burned out. Therefore, only use 3-phase motors.

Power Transmission Mechanism (Gear Reduction, Belt, Chain, etc.)

When gear boxes and change/reduction gears lubricated with oil are used in power transmission systems, (Continuous low speed operation decreases the oil lubrication function). Also, operation at more than 60Hz may result in noise, reduced life, etc.

F. PERIPHERAL UNIT NOTES

Installation and selection of molded-case circuit breaker

On the input power side, a molded case circuit breaker (MCCB) to protect inverter primary wiring should be installed. The inverter power factor (depending on power voltage, output frequency, and load) must be taken into account for selecting the MCCB. For standard selection, see If a full electromagnetic MCCB is to be used, select a larger capacity because the operating characteristics are altered by harmonic current. A leakage current breaker of inverter use is recommended.

Use of input side magnetic contactor

The inverter can be used without an input side magnetic contactor (MC). An input MC can be used to prevent an automatic restart after recovery from an external power loss during remote control operation. However, do not use the MC frequently for start/stop operation, or it will lead to a reduced reliability. When the digital operator is used, automatic restart after power failure is disabled so that MC starting is impossible. Although the MC can stop the inverter, regeneration braking is disabled and the motor coasts to stop.

Use of secondary magnetic contactor

In general, magnetic contactors on the output of the inverter for motor control should not be used. Starting a motor with the inverter running will cause large surge currents and the inverter overcurrent protector to be triggered. If an MC is used for switching to commercial power supply, switch MC after the inverter and the motor stop. To switch during motor rotation, use the speed search function.

Use of overload relay

The inverter includes an electronic thermal protective function to protect the motor from overheating. If more than one motor is driven with a single inverter or when a multi-pole motor is used, place an overload relay between the inverter and the motor. Set 1 to the first position of Sn-14 (xxx1), and set the overload relay to the current nameplate value at 50Hz, or 1.1 times of that at 60 Hz.

Power-factor improvement (elimination of phase advance capacitor)

To improve the power-factor, install an AC reactor on the inverter's primary side. Power-factor improvement capacitors or surge suppressors on the inverter output side will be damaged by the harmonic component in the inverter output. Also, the overcurrent caused in the inverter output will trigger the overcurrent protection. To avoid this, do not use capacitors or surge suppressors in the inverter's output. To improve the power-factor, install an AC reactor on the inverter primary side.

Radio frequency interference

Because the inverter I/O (main circuit) contains a higher harmonics component, it may emit RFI noise to communication equipment (AM radio, etc.) near the inverter. Use a noise filter to decrease the noise. Use of a metallic conduit between the inverter and motor and grounding the conduit is also effective. Proper routing of input and output leads is also recommended.

Wire thickness and cable length

If the inverter is connected to a distant motor, (especially when low frequency is output,) motor torque decreases because of voltage drop in the cable. Use sufficiently heavy wire.

When a digital operator is to be installed separately from the inverter, use the TECO connection cable (option). For remote control with analog signals, connect the operating pot or operating signal terminal and the inverter within 30m of the inverter. The cable must be routed separately from power circuits (main circuit and relay sequence circuit) so that it is not subjected to inductive interference by other equipment. If frequencies are set not only from the digital operator but also with external frequency controller, use twisted pair shielded wire as shown in the following figure and connect the shielding to terminal E, not to the ground.

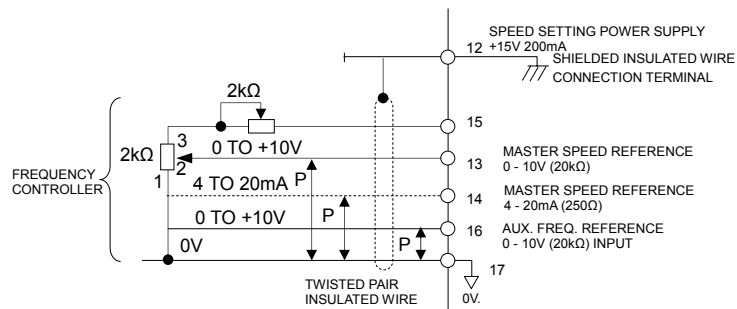

G. CIRCUIT PROTECTION AND ENVIRONMENTAL RATINGS NOTES

Circuit Protection

The maximum rms symmetrical amperes and voltage of 7200GS series are to listed as follows

Device Rating		Short circuit Rating (A)	Maximum Voltage (V)
Voltage	HP		
220V	25 ~ 50	5,000	240V
	51 ~ 100	10,000	
440V	25 ~ 50	5,000	480V
	51 ~ 200	10,000	
	201 ~ 400	18,000	

Environmental Ratings

The 7200GS is suitable for use in pollution degree 2 environments.

Field Wiring Terminals and Tightening Torque

The wiring terminals and tightening torque as follows.

(The main circuit terminal specifications – use 60/75°C copper wire only)

(a) 220V class

Circuit	Inverter Rating (HP)	Terminals Mark	Cable Size (AWG)	Terminals	Tightening Torque (pound-in.)
Main Circuit	25	L1, L2, L3, T1, T2, T3, B2, ⊕, ⊖	4	M6	35
		⊕	6	M6	35
	30	L1, L2, L3, T1, T2, T3, ⊕, ⊖	4	M8	78
		⊕	6	M10	156
	40	L1, L2, L3, T1, T2, T3, ⊕, ⊖	2/0	M8	78
		⊕	4	M10	156
	50	L1, L2, L3, T1, T2, T3, ⊕, ⊖	2/0	M8	78
		⊕	4	M10	156
	60	L1, L2, L3, T1, T2, T3, ⊕, ⊖	2/0 x 2P	M8	78
		⊕	4	M10	156
	75	L1, L2, L3, T1, T2, T3, ⊕, ⊖	2/0 x 2P	M8	78
		⊕	2	M10	156
	100	L1, L2, L3, T1, T2, T3, ⊕, ⊖	4/0 x 2P	M10	156
		⊕	1/0	M10	156
Control Circuit	All series	1 ~ 33	24 - 14	M3	5

(b) 440V class

Circuit	Inverter Rating (HP)	Terminals Mark	Cable Size (AWG)	Terminals	Tightening Torque (pound-inch)
Main Circuit	25	L1, L2, L3, T1, T2, T3, B2, ⊕, ⊖	8	M4	10
		⊕	8	M6	35
	30	L1, L2, L3, T1, T2, T3, B2, ⊕, ⊖	8	M4	10
		⊕	8	M6	35
	40	L1, L2, L3, T1, T2, T3, ⊕, ⊖	6	M6	35
		⊕	8	M10	156
	50	L1, L2, L3, T1, T2, T3, ⊕, ⊖	4	M6	35
		⊕	6	M10	156
	60	L1, L2, L3, T1, T2, T3, ⊕, ⊖	4	M8	78
		⊕	6	M10	156
	75	L1, L2, L3, T1, T2, T3, ⊕, ⊖	1	M8	78
		⊕	4	M10	156
	100	L1, L2, L3, T1, T2, T3, ⊕, ⊖	2/0	M8	78
		⊕	4	M10	156
	125	L1, L2, L3, T1, T2, T3, ⊕, ⊖	2/0 x 2P	M10	156
		⊕	4	M10	156
	150	L1, L2, L3, T1, T2, T3, ⊕, ⊖	2/0 x 2P	M10	156
		⊕	2	M10	156
	175	L1, L2, L3, T1, T2, T3, ⊕, ⊖	2/0 x 2P	M10	156
		⊕	2	M10	156
215	L1, L2, L3, T1, T2, T3, ⊕, ⊖	4/0 x 2P	M10	156	
	⊕	1/0	M10	156	
250	L1, L2, L3, T1, T2, T3, ⊕, ⊖	4/0 x 2P	M10	156	
	⊕	1/0	M10	156	
300	L1, L2, L3, T1, T2, T3, ⊕, ⊖	4/0x 2P	M10	156	
	⊕	2/0	M10	156	
400	L1, L2, L3, T1, T2, T3, ⊕, ⊖	650 x 2P	M10	156	
	⊕	2/0	M10	156	
Control Circuit	All series	1 ~ 33	20 - 14	M3	5

H. DRIVE INPUT FUSES

■ Drive input fuses are provided to disconnect the drive from power in the event that a component fails in the drive's power circuitry . The drive's electronic protection circuitry is designed to clear drive output short circuits and ground faults without blowing the drive input fuses . Below table shows the 7200GS input fuse ratings.

Inverter		Drive Input Fuse Ratings (Semiconductor protection)		
Voltage	HP	Rated Voltage	Amps	Fuse Type (FERRAZ)
220V	25	300VAC	125	A30QS125-4
	30		150	A30QS150-4
	40		175	A30QS175-4
	50		250	A30QS250-4
	60		250	A30QS250-4
	75		350	A30QS350-4
	100		450	A30QS450-4
440V	25	500VAC	60	A50QS60-4
	30		70	A50QS70-4
	40		90	A50QS90-4
	50		125	A50QS125-4
	60		125	A50QS125-4
	75		175	A50QS175-4
	100		225	A50QS225-4
	125		300	A50QS300-4
	150		350	A50QS350-4
	175		400	A50QS400-4
	215		450	A50QS450-4
	250		500	A50QS500-4
	300		600	A50QS600-4
400	900	A50QS900-4		

I. CERTIFICATION FOR THE INVERTER

■ CE Mark

- The 7200GS drives conform to the European Union Electromagnetic Compatibility Directive, when installed according to the recommendations described in the “EMC Installation Guideline” manual.
- The tests were made in accordance with the following basic standards:
 - EN55011 (2000-05) : Conducted Emission and Radiated Emission.
 - EN61000-4-2 (1995-03) : ESD
 - EN61000-4-3 (1998) : RFI Immunity
 - EN61000-4-4 (1995-03) : Fast Transient (Burst)
 - EN61000-4-5 (1995-03) : Slow Transient (Surge)
 - EN61000-4-6 (1996-07) : RF Common Mode Immunity
 - EN61000-4-11(1994) : Voltage Dips, Short Interruptions and Voltage Variations Immunity



TECO Electric & Machinery Co., Ltd.

10F., No.3-1, Yuancyu St., Nangang District,
Taipei city 115, Taiwan
Tel : +886-2-6615-9111
Fax : +886-2-6615-0933

<http://www.teco.com.tw>